

INDEPENDENCE CITY COMMISSION

**REGULAR SESSION AGENDA**

April 23, 2026

5:30 PM

Commission Room City Hall

To participate by conference call:  
1 785-289-4727 Conference ID: 569 533 576#

The Agenda shall be as follows:

I. REGULAR SESSION

- A. Call to Order
- B. Pledge of Allegiance to the United States of America
- C. Adoption of Agenda

II. APPOINTMENTS

- A. Consider appointing a new board member to a 1st term on the Housing Authority Board expiring on April 11, 2030.

III. PRESENTATIONS

- A. Discuss public feedback from the Community-Based Strategic Plan focus groups and surveys.
- B. Introduction and swearing-in of Independence Police Department's new officers.

IV. CONSENT AGENDA

(*Consent* is that class of Commission action that requires no further discussion or which is routine in nature. All items on the Consent Agenda are adopted by a single motion unless removed from the Consent Agenda.)

- A. Consider authorizing pre-application for a KDHE revolving loan for completion of the Water Treatment Plant Master Plan project.
- B. Consider authorizing application for KDOT City Connecting Link Improvement Program (CCLIP) grant for FY 2028 Surface Preservation – Main Street, 2<sup>nd</sup> Street to City Limits.
- C. Consider setting the date of May 21, 2026 to receive demolition bids for structures previously condemned as dangerous and unsafe.

V. PUBLIC HEARING

- A. Public Hearing to consider condemnation of 1028 W. Chestnut Street as dangerous and unsafe.

VI. ITEMS FOR COMMISSION ACTION

- A. Consider a resolution to rescind the condemnation action of 620 W. Chestnut Street.
- B. Consider setting the date of June 25, 2026, for a Public Hearing to consider the condemnation of 1208 W. Myrtle as dangerous and unsafe.
- C. Consider approving a 20-minute parking stall at 305 E. Main Street.
- D. Consider a request regarding ADA complaint related to accessibility access.
- E. Consider recommendation from the Planning Commission to amend the zoning code and adopt a landscaping ordinance.

- F. Consider closing Locust from Penn to 6th Street, 6th Street from Locust to Chestnut, and Chestnut from 5th to 6th Street for the Independence High School Prom on Saturday, May 2, 2026 from 4:00 PM to approximately 8:30 PM.
- G. Consider award of the construction of the 2026 Salt-Sand Storage project to A&B Construction, LTD in the amount of \$114,130.00.
- H. Consider a contract addendum with Green Environmental Recycling and Disposal, LLC for landfill services.
- I. Consider purchasing two replacement salt/sand spreaders from American Equipment Company for \$50,244.00.
- J. Consider proclaiming May 3-9, 2026 as Public Service Recognition Week.

VII. REPORTS

- A. City Board Minutes
- B. Public Works and Project Report
- C. Appropriations

VIII. CITY MANAGER'S COMMENTS

IX. COMMISSIONERS' COMMENTS

X. PUBLIC CONCERNS

XI. EXECUTIVE SESSION

- A. Consultation with an attorney on matters that would be deemed privileged in an attorney-client relationship.

XII. ADJOURNMENT



**REQUEST FOR COMMISSION ACTION  
CITY OF INDEPENDENCE**

**April 23, 2026**

**Department Admin**

**Director Approval Kelly Passauer**

**AGENDA ITEM** Consider appointing a new board member to a 1st term on the Housing Authority Board expiring on April 11, 2030.

**SUMMARY RECOMMENDATION**

**BACKGROUND** The term on the Housing Authority Board for Rita Ortolani expired on April 11, 2026. Rita Ortolani does not wish to be reappointed. We wish to thank Rita for her years of service. Members of this board must reside within the City limits. We received two applications from City residents by the April 15, 2026 deadline.

**FINANCIAL INFORMATION** N/A

**SUGGESTED MOTION** I move to appoint \_\_\_\_\_ to a 1st term on the Housing Authority Board expiring on April 11, 2030.

**SUPPORTING DOCUMENTS**

1. HousingAuthority-ChappuieAnita-Received04082026\_Redacted
2. HousingAuthority-McDillDaniel-Received04082026\_Redacted

---

**Online Form Submittal: Board Application**

---



**From** noreply@civicplus.com <noreply@civicplus.com>

**Date** Wed 4/8/2026 9:05 AM

**To** Kelly Passauer <kellyp@independences.gov>

**CAUTION: This email is from outside of the organization. Do not click links or open attachments. Verify the emails source before taking action. When in doubt, contact your IT Dept.**

### Board Application

|  |   |
|--|---|
| Board Applying For:                                      | Housing Authority   |
| Name   | Anita Chappuie  |
| Date   | 4/8/2026  |
| Address  | 408 N. 12TH ST  |
| Email Address  |  |
| Phone Number   |  |
| <b>Educational Background:</b>                           |   |
| High School Name and Location                            | Independence High School  |
| Graduated/Degree   | 2007 HS Diploma   |
| College Name and Location                                | Independence Community College  |
| Graduated/Degree   | 2009 AS   |
| Major  | Liberal Studies   |
| Other Education Name and Location                        | University of Kansas  |
| Graduated/Degree   | 2011 BGS; 2015 JD   |
| Emphasis   | Poli Sci; Law   |
| Do you reside inside the corporate limits of the City of | Yes   |

Independence?

---

If no, do you reside within 3 miles of the corporate limits of the City of Independence? *Field not completed.*

---

What experiences have you had that you feel would assist you as a board member? As a graduate of KU School of Law, I feel prepared for the regulatory and statutory interpretation and understanding that will be necessary for a board member. I'm also currently serving on the Planning Commission & Board of Zoning Appeals; which could be useful to have someone on both boards who can bring an understanding and awareness of the broader picture of things going on in the city.

---

Why do you want to become a member of the board? I strongly believe in the importance of good local governance and I believe serving on city boards like this is one of the best ways citizens can help support their local government. I also think my particular combination of skills and experience can be an asset to this board.

---

Do you feel that there are any issues needing immediate attention by the board? If so, please explain. I know the availability of housing options is an issue facing our city that this board is already working to address. I would love the opportunity to assist in that work.

---

Other comments: *Field not completed.*

---

Email not displaying correctly? [View it in your browser.](#)

---

**Online Form Submittal: Board Application**

---

**From** noreply@civicplus.com <noreply@civicplus.com>

**Date** Wed 4/8/2026 10:29 PM

**To** Kelly Passauer <kellyp@independencesks.gov>

**CAUTION: This email is from outside of the organization. Do not click links or open attachments. Verify the emails source before taking action. When in doubt, contact your IT Dept.**

**Board Application**

|  |  |
|--|--|
| Board Applying For:                                      | Housing Authority Board                          |
| Name   | Daniel McDill                                    |
| Date   | 4/8/2026   |
| Address  | 924 N Pennsylvania Ave, #119                     |
| Email Address  | [REDACTED]                                       |
| Phone Number   | [REDACTED]                                       |
| <b>Educational Background:</b>                           |  |
| High School Name and Location                            | Independence High School, Independence, KS 67301 |
| Graduated/Degree   | 2011 - Diploma                                   |
| College Name and Location                                | Pittsburg State University - Pittsburg, KS 66762 |
| Graduated/Degree   | 2016 - Bachelors                                 |
| Major  | Music Education                                  |
| Other Education Name and Location                        | Pittsburg State University - Pittsburg, KS 66762 |
| Graduated/Degree   | 2018 - Masters                                   |
| Emphasis   | Music - Orchestral Conducting                    |
| Do you reside inside the corporate limits of the City of | Yes  |

Independence?

---

If no, do you reside within 3 miles of the corporate limits of the City of Independence?

*Field not completed.*

---

What experiences have you had that you feel would assist you as a board member?

I have had several leadership and board experiences that I believe would help me contribute effectively as a member of the Housing Authority board. I founded a nonprofit organization in Kansas City and served on its board for several years, where I gained experience in governance and organizational leadership by working with others to make decisions that benefited the members and their community. I currently serve on the board of Independence Children's Summer Theatre, where I help support programming that provides opportunities for youth and families in Independence. Throughout college and in the years since, I have served in leadership roles in various organizations, which helped me develop strong collaboration and problem-solving skills. These experiences have given me a solid understanding of how boards operate and how thoughtful leadership can positively impact a community.

---

Why do you want to become a member of the board?

I grew up in Independence, and I would like the opportunity to give back to the community that helped shape me into the person I am today. Serving on the Housing Authority board would allow me to contribute to the continued growth and strength of our community while also gaining a better understanding of how our local organizations work to serve residents. I am especially interested in being part of efforts that help revitalize Independence and ensure that quality housing is available for young professionals and families who want to live and build their lives here. I believe strong housing opportunities are an important part of a thriving community, and I would be proud to play a role in supporting that mission.

---

Do you feel that there are any issues needing immediate attention by the board? If so, please explain.

One issue I believe deserves attention is the limited availability of FHA-eligible homes in Independence, particularly in the price range below roughly \$120,000. When looking at the job and income data in our area, many working individuals and young families rely on FHA financing as one of the few realistic paths to homeownership. If there are not enough homes that qualify for these programs, it can make it difficult for young working professionals in our community to purchase homes and put down long-term roots here. I believe this is an important topic for the Housing Authority and community partners to explore so we can ensure that safe, affordable housing options remain available for current residents and for those who want to move to Independence.

---

Other comments:

*Field not completed.*

---

Email not displaying correctly? [View it in your browser.](#)



**Discussion Item**  
**CITY OF INDEPENDENCE**  
**April 23, 2026**

---

**Department Admin**

**Director Approval Kelly Passauer**

**AGENDA ITEM** Discuss public feedback from the Community-Based Strategic Plan focus groups and surveys.

**BACKGROUND** Mackey Smith is the consultant with Vickrey Leadership Solutions that is preparing the City's Community-Based Strategic Plan. Mackey previously provided the attached memo that outlines the number of respondents, some initial high level takeaways from the survey, and preferred next steps and timeline. At the Commission meeting, Mackey Smith will virtually review the feedback from the focus groups and survey analysis regarding the Community-Based Strategic Plan.

**SUPPORTING DOCUMENTS**

1. City of Independence Strategic Plan and Outreach Update April 9 2026

# City of Independence Strategic Plan and Outreach Update – 4/9/2026

## Executive Summary for the City Commission

We are very pleased with the strong community participation in the 2026 City of Independence community survey. In total, **525 residents responded**, with **521 respondents completing substantial portions of the survey**, providing a strong and reliable foundation for analysis.

Our team is currently completing a quality assurance review of the analysis and slide deck. A comprehensive report summarizing survey results and progress since the City’s last survey in 2023 will be ready for **review and discussion at the April 23 City Commission meeting**.

## Initial High-Level Survey Takeaways

### Improved Age Representation

This survey achieved the most balanced age distribution across all three iterations of the survey conducted to date. In prior surveys, respondents age 65 and older made up **55% of respondents in 2021** and **47% in 2023**. In contrast, residents age 65 and over represented **27% of respondents in the 2026 survey**, reflecting broader participation across age groups.

### City Services Performance (Net Promoter–Style Scoring)

Using a consistent scoring methodology—where responses on a 1–5 scale are grouped as negative (1–2), neutral (3), and positive (4–5)—the City received strong positive scores in several key service areas:

- **Parks & Recreation: +58**
- **Public Safety: +38**
- **Utility Services: +33**
- **Customer Service: +27**

These results point to clear strengths in City service delivery and areas of continued success.

### Areas for Continued Attention

The only service area to receive a negative score was **Code Enforcement (–10)**. Notably, this represents an improvement from **–16 in 2023**. Focus group feedback indicates that

residents recognize the progress the City has made in this area and would welcome continued discussion and refinement moving forward.

### **Overall City Services Score**

The overall City services score dipped slightly to **+21**, which is still classified as a good score. Feedback gathered through both the survey and focus groups suggests this modest decrease reflects resident concerns related to perceived areas for improvement, particularly **infrastructure and street maintenance**.

### **Focus Group Engagement**

In addition to the survey, the City conducted **15 focus groups** with members of the public and targeted stakeholder groups. These sessions included participation from:

- The **Economic Development Advisory Board**
- The **Chamber of Commerce**
- The **Planning Commission**
- **Parks and Recreation, Economic Development**, and other local boards
- **Historic Main Street** stakeholders
- Civic organizations such as the **Lions Club, Rotary Club**, and **Optimists**
- **Housing and Neighborhood Stability** stakeholders
- A **City staff focus group**
- Public, open-attendance community sessions
- A focus group conducted entirely in **Spanish** for Hispanic community members who prefer Spanish as their primary language

Across all focus group sessions, **more than 150 residents, stakeholders, and staff** participated, providing important qualitative insight to complement the survey findings.

### **Next Steps**

A more detailed written report will be issued in the coming week. Recommended next steps include:

1. Scheduling a dedicated working session with the City Commission and City leadership to review the findings in greater depth.

2. Scheduling **two virtual meetings in May** to begin developing the outline of the City's strategic plan.
3. Convening follow-up meetings with select department heads to gather input on identified priorities and support the drafting of actionable initiatives designed to drive the City's long-term success.

Thank you for your time and continued engagement in this process. We look forward to reviewing the full findings with the City Commission at an upcoming meeting and partnering with City leadership to translate community input into clear priorities and actionable strategies.

**Mackey Smith**

**Vickrey Leadership Solutions**

[mackey@vlsconsultants.com](mailto:mackey@vlsconsultants.com)



**Presentation**  
**CITY OF INDEPENDENCE**  
**April 23, 2026**

**Department Police**

**Director Approval Dustin Stafford**

**AGENDA ITEM** Introduction and swearing-in of Independence Police Department's new officers.

**BACKGROUND** Christian Ortiz and Teely Signer were selected to serve the citizens of Independence as police officers.

Christian Ortiz started with us in the fall of 2025. He graduated from the Kansas Law Enforcement Training Center's Basic Training Course on March 20th, 2026. Christian was born and raised in Southern California and moved to Southeast Kansas in mid-June 2020. He fell in love with the small town feeling and decided it was time to get out of the big city life. He has been married for 8 years to his wife Janette, and they have 4 children, ranging from 8 years old to two months old. They love independence and think it's the perfect place to raise a family. Christian always wanted to be in Law Enforcement. Living in Independence solidified his decision to join Law Enforcement to continue to keep the City of Independence safe for his family and for the kind and loving citizens of Independence who make this town feel like home.

Teely Signer started with us in March. In 2025, she worked for the Elk County Sheriff's Department and graduated from the Kansas Law Enforcement Training Center's Basic Training Course. She grew up in Southeast Kansas and has been in Kansas most of her life. She is a mother and a wife and has 4 dogs and 4 cats. She has been in law enforcement for at least a year and fully believes it is her passion for her working career. She enjoyed serving and protecting the community of Elk county and hopes to continue this passion with the City of Independence.

The City Clerk will swear-in Officers Ortiz and Signer using the following: I do solemnly swear that I will support the constitution of the United States and the Constitution of the state of Kansas, and faithfully discharge the duties of police officer for the City of Independence, Kansas. So help me God.

**SUPPORTING DOCUMENTS**



**REQUEST FOR COMMISSION ACTION  
CITY OF INDEPENDENCE**

**April 23, 2026**

**Department Public Works & Utilities**

**Director Approval John Garris**

**AGENDA ITEM** Consider authorizing pre-application for a KDHE revolving loan for completion of the Water Treatment Plant Master Plan project.

**SUMMARY RECOMMENDATION** Authorize pre-application for loan.

**BACKGROUND** On August 18, 2021, the Commission approved the Water Treatment Plant Master Plan to guide the operational philosophy and identify the capital spending required to maintain City water quality and capacity. PEC was engaged as the engineering firm for this Plan.

The attached sheet summarizes the capital items that will be included with the project. The projects identified in the 2026 column have been funded via an existing State Revolving Fund loan. Upon KDHE approval, a request to bid those projects will be brought to the Commission for approval.

In order to fund the 2027 work, a new pre-application is needed to request a new State Revolving Fund loan. This application is attached and will be filed upon Commission approval. It is anticipated that, if approved, the actual loan application will be brought before the Commission for approval in the third or fourth quarter of 2026. The total in the application adds engineering and inspection costs to the \$3,029,000 total for this phase of work.

**FINANCIAL INFORMATION** No costs are incurred to file the pre-application and the City is not obligated to take the loan.

**SUGGESTED MOTION** I move to approve a pre-application for a State Revolving Fund loan in the amount of \$4,278,000.

**SUPPORTING DOCUMENTS**

1. Independence WTP Phase 3 Project SRF Pre-Application Form
2. Project Timing And Completion - Budget\_9-30-25



PRE-APPLICATION FORM

Can be used for Kansas Public Water Supply Loan Fund (KPWSLF) or Kansas Water Pollution Control Revolving Fund (KWPCRF) projects

Municipality Name: City of Independence
Contact Name and Title: John Garris, Public Works & Utilities Director
Mailing Address: 120 N 6th, Independence, KS 67301
Phone: 620-926-0976
Email Address: engineer@independenceks.gov

Project Description

The City of Independence Phase 3 (Clearwell Improvements) project shall include the design, bidding, geotechnical investigation, field survey, and construction administration services for the rehabilitation of the existing north clearwell, the addition of a new clearwell to replace the existing south clearwell, and the demolition of the abandoned tank north of the two existing clearwells. This project also includes an evaluation of system hydraulics and storage capacity requirements.

Describe the Problem the Project will resolve

The City of Independence Phase 3 (Clearwell Improvements) project aims to resolve several critical issues:

- 1. Improve risk resiliency at the Water Treatment Plant by adding redundancy to the on-site finished water storage. There are currently two clearwells in service, and this project will add clearwell capacity.
2. Add more on-site storage capacity at the Water Treatment Plant as the City adds more water demand in the future. This includes the water demand required by the new Bartlett soybean plant.
3. Improve the structural integrity of an existing clearwell (north) to ensure reliable operation.

Est. Design Completion Date: 2/1/2027
Status of Design (% Complete): 0%
Est. Project Construction Start Date: 6/1/2027
Estimated Project Cost: \$4,278,000

Rural Water Districts must attach a list showing the number of customer meters in each county township. If the utility currently implements an asset management plan, please attach the completed Asset Management IQ Test found at http://southwestefc.unm.edu/AssetManagementIQ/main.php. If the project is for lead service line replacements, indicate in the project description whether there will be a charge to property owners for replacing the private side of lead service lines. If the municipality wishes for a lead service line or distribution project area to be considered as a Disadvantaged Community, a list of census tracts for the project area must be attached. Send completed form and attachments to: KDHE-SRF, 1000 SW Jackson, Suite 420; Topeka, KS 66612 or email to kdhe.KansasSRF@ks.gov.

| Phase                       | Project Description                                   | % Design Complete | Reference Page | Cost               | 2026               | 2027               | 2028               | 2029             |
|-----------------------------|---|-------------------|----------------|--------------------|--------------------|--------------------|--------------------|------------------|
| 2 <sup>3</sup>              | Existing Clarifier Rehab                              | 100%              | 6-2            | \$425,000          | \$425,000          |                    |                    |                  |
|                             | Partial Sludge Piping Replacement                     | 100%              | 6-2            | \$43,475           | \$43,475           |                    |                    |                  |
|                             | Chlorination System Improvements                      | 100%              | 6-4            | \$619,400          | \$619,400          |                    |                    |                  |
|                             | Site Security Fencing                                 | 100%              | 6-7            | \$170,000          | \$170,000          |                    |                    |                  |
|                             | Demolition  | 100%              | 6-7            | \$50,000           | \$50,000           |                    |                    |                  |
|                             | Concrete Floor Re-coating                             | 100%              | 6-7            | \$50,000           | \$50,000           |                    |                    |                  |
|                             | High Service Pump Station Flood Wall/Bracing          | 100%              | 6-5            | \$150,000          | \$150,000          |                    |                    |                  |
|                             | Waste Stream Improvements                             | 100%              | N/A            | \$1,696,662        | \$1,696,662        |                    |                    |                  |
| 3                           | New Clearwell   | 0%                | 6-4            | \$3,029,000        |                    | \$3,029,000        |                    |                  |
|                             | North Clearwell Rehab                                 | 0%                | 6-4            | \$850,500          |                    | \$850,500          |                    |                  |
| 4<br>(previous Phase 3)     | Filter Building Renovations <sup>2</sup>              | 90% <sup>1</sup>  | 6-7            | \$877,000          |                    |                    | \$877,000          |                  |
|                             | East or West Basin Concrete Slab <sup>2</sup>         | 90% <sup>1</sup>  | 6-4            | \$240,000          |                    |                    | \$240,000          |                  |
|                             | North Basin Repairs <sup>2</sup>                      | 90% <sup>1</sup>  | 6-4            | \$756,000          |                    |                    | \$756,000          |                  |
| 5                           | Rapid Mix Replacement <sup>2</sup>                    | 0%                | 6-3            | \$36,000           |                    |                    |                    | \$36,000         |
|                             | Slow Mix Rehabilitation <sup>2</sup>                  | 0%                | 6-3            | \$84,000           |                    |                    |                    | \$84,000         |
|                             | Residuals Lagoon Sludge Disposal Pumping <sup>2</sup> | 0%                | 6-8            | \$676,000          |                    |                    |                    | \$676,000        |
| <b>Total Project Costs:</b> |   |                   |                | <b>\$9,753,037</b> | <b>\$3,204,537</b> | <b>\$3,879,500</b> | <b>\$1,873,000</b> | <b>\$796,000</b> |

1: Design plans were taken to 100% in 2022; listing as 90% complete because design will need to be reviewed before reissuing

2: Costs from last update were increased by a flat 20%

3: Plans and specifications with KDHE for review

4: Phase 3-5 timing is estimated based on previous schedule; actual timing will be per final City decision on order of projects



**REQUEST FOR COMMISSION ACTION  
CITY OF INDEPENDENCE**

**April 23, 2026**

**Department Public Works & Utilities**

**Director Approval John Garris**

**AGENDA ITEM** Consider authorizing application for KDOT City Connecting Link Improvement Program (CCLIP) grant for FY 2028 Surface Preservation – Main Street, 2<sup>nd</sup> Street to City Limits.

**SUMMARY RECOMMENDATION** Authorize application for grant.

**BACKGROUND** Kansas Department of Transportation (KDOT) City Connecting Link Improvement Program (CCLIP) applications are due May 1, 2026 for FY 2028 (July 1, 2027 – June 30, 2028) projects. If approved, the attached applications will be submitted.

The following project is suggested:

CCLIP Application, Surface Preservation – Main Street, 2<sup>nd</sup> to City Limits – mill and overlay pavement. Previously, the City had requested sidewalk to be approved as well, but this has not been approved by KDOT. The City may decide to bid sidewalk work with this project, but it is not included in the application.

| <b>Estimated Cost</b> | <b>Estimated City Match – (10%)</b> | <b>Non-Participating Costs</b> | <b>Total City Cost</b> |
|-----------------------|-------------------------------------|--------------------------------|------------------------|
| \$481,515.00          | \$39,022.20                         | \$91,293.00                    | \$130,315.00           |

**FINANCIAL INFORMATION** No costs are incurred in application for the grant.

**SUGGESTED MOTION** I move to approve an application for KDOT’s CCLIP Program for Main Street, from 2<sup>nd</sup> to City Limits, and for execution of any necessary documents required by KDOT.

**SUPPORTING DOCUMENTS**

1. Copy of Independence Surface Preservation CCLIP Application Form 1330
2. CCLIP 2nd to CL - PLAN With Sidewalk
3. CCLIP 2nd to City Limits Cost Estimate 2026

KANSAS DEPARTMENT OF TRANSPORTATION - BUREAU OF LOCAL PROJECTS

**CITY CONNECTING LINK IMPROVEMENT PROGRAM (CCLIP) APPLICATION**

|                             |                                  |
|-----------------------------|----------------------------------|
| <b>Program Category:</b>    | <b>Surface Preservation (SP)</b> |
| <b>Program Fiscal Year:</b> | <b>2028</b>                      |
| Submittal Date:             |                                  |

|                             |                                     |
|-----------------------------|-------------------------------------|
| <b>Name of City:</b>        | <b>City of Independence, Kansas</b> |
| County of Project Location: | Montgomery                          |
| Population of City:         | 9000                                |
| State Highway of Project:   | 160                                 |

|   |   |
|---|---|
| Primary Contact Name and Title:                       | John Garris, City Engineer  |
| Contact Address:                                      | 120 North 6th Street, Independence, Ks 67301  |
| Phone:  | 620 926 0976  |
| E-mail Address:                                       | <a href="mailto:engineer@independencesks.gov">engineer@independencesks.gov</a>  |
| <u>Date of City Connecting Link (CCL) Resolution:</u> | 9/1/2011  |
| Is the CCL resolution accurate?                       | <input checked="" type="checkbox"/> Yes, it matches our current city limits <input type="checkbox"/> No, our city limits have changed |

|  |
|--|
| <b>Project Location:</b>   |
| Beginning at 2nd Street, and then proceeding East to the City Limits on US 160 (Main Street)     |
| <b>Project Scope:</b>  |
| Mill and overlay. Replace curb and gutter at one quadrant and replace one storm water inlet box. |
| <b>Project Length:</b> 0.450 miles   |

| RR within 1/2 mile? | RR Company Name | No. of Tracks | Existing Crossing Protection |
|---------------------|-----------------|---------------|------------------------------|
| No                  |                 |               |                              |

| Project Cost Estimate               |                      |                     |                      |          |
|-------------------------------------|----------------------|---------------------|----------------------|----------|
|                                     | Participating        | Non-Participating   | Total                | Comments |
| Preliminary Engineering (Design)    | \$ -                 | \$ 40,000.00        | \$ 40,000.00         |          |
| CE (Inspection)                     | \$ -                 | \$ 40,000.00        | \$ 40,000.00         |          |
| Right of Way                        | \$ -                 |                     | \$ -                 |          |
| Utility Adjustments                 | \$ -                 |                     | \$ -                 |          |
| <b>Construction Total</b>           | <b>\$ 341,950.00</b> | <b>\$ -</b>         | <b>\$ 341,950.00</b> |          |
| Grading                             | \$ 1,000.00          | \$ -                | \$ 1,000.00          |          |
| Surfacing (Asphalt)                 | \$ 310,000.00        | \$ -                | \$ 310,000.00        |          |
| Surfacing (Concrete)                | \$ -                 | \$ -                | \$ -                 |          |
| Signing and Pavement Marking        | \$ 30,950.00         | \$ -                | \$ 30,950.00         |          |
| Lighting                            | \$ -                 | \$ -                | \$ -                 |          |
| Seeding                             | \$ -                 | \$ -                | \$ -                 |          |
|                                     | \$ -                 | \$ -                | \$ -                 |          |
|                                     | \$ -                 | \$ -                | \$ -                 |          |
| Inflation Amount at 4.5% / year     | \$ 48,272.00         | \$ 11,293.00        | \$ 59,565.00         |          |
| <b>Total Estimated Project Cost</b> | <b>\$ 390,222.00</b> | <b>\$ 91,293.00</b> | <b>\$ 481,515.00</b> |          |

|                            |   |
|----------------------------|---|
| Program Maximum:           | \$ 400,000.00                               |
| Allowable Project Maximum: | \$ 444,444.44 to not exceed Program Maximum |
| Local Share Percentage:    | 10%   |
| KDOT Share Percentage:     | 90%   |

|                          |              |
|--------------------------|--------------|
| Local Match ( 10% )      | \$ 39,022.20 |
| Local Match over the Max | \$ -         |

KANSAS DEPARTMENT OF TRANSPORTATION - BUREAU OF LOCAL PROJECTS

**CITY CONNECTING LINK IMPROVEMENT PROGRAM (CCLIP) APPLICATION**

|                             |                                  |  |
|-----------------------------|----------------------------------|--|
| <b>Program Category:</b>    | <b>Surface Preservation (SP)</b> |  |
| <b>Program Fiscal Year:</b> | <b>2028</b>                      |  |
| Submittal Date:             |                                  |  |

|                                  |           |                   |
|----------------------------------|-----------|-------------------|
| Non-Participating                | \$        | 91,293.00         |
| <b>Total Local Share</b>         | <b>\$</b> | <b>130,315.20</b> |
| <b>Total Requested from KDOT</b> | <b>\$</b> | <b>351,199.80</b> |

|  |                  |
|--|------------------|
| <b>Coordination Information:</b>   |                  |
| Describe any known KDOT or other projects that may need coordination:                    |                  |
| None   |                  |
| Has the proposed project been discussed or reviewed by any KDOT field staff? (Yes or No) | Yes              |
| If so, who?  | Darren Petrowski |

**Attachment Checklist:**

- a. Project Map
- b. Detailed cost estimate

Completed applications should be emailed to:

[KDOT.LPePlans@ks.gov](mailto:KDOT.LPePlans@ks.gov)

To confirm receipt, if you do not receive an email response, please follow up with a call to the Bureau of Local Projects at (785)



**Opinion of Probable Construction Cost  
 Cost Estimate  
 City of Independence  
 CCLIP 2nd to City Limits**

| ITEM NO. | BID ITEM                                | UNIT | UNIT BID PRICE | QUANTITY | COST          |
|----------|---|------|----------------|----------|---------------|
| 1        | Contractor Construction Staking         | LSUM | \$10,000.00    | 1        | \$ 10,000.00  |
| 2        | Mobilization                            | LSUM | \$35,000.00    | 1        | \$ 35,000.00  |
| 3        | Milling 2"                              | SY   | \$6.00         | 12000    | \$ 72,000.00  |
| 4        | Rock Excavation                         | CY   | \$25.00        | 115      | \$ 2,875.00   |
| 5        | Compaction of Earthwork (Type B)(MR-90) | CY   | \$3.00         | 300      | \$ 900.00     |
| 6        | Top Soil                                | CY   | \$10.00        | 30       | \$ 300.00     |
| 7        | Curb and Gutter                         | LF   | \$150.00       | 60       | \$ 9,000.00   |
| 8        | HMA Surface (2")                        | TON  | \$125.00       | 1295     | \$ 161,875.00 |
| 9        | Curb Inlet Type 22                      | EA   | \$5,500.00     | 1        | \$ 5,500.00   |
| 10       | Remove Existing Storm Inlet             | LSUM | \$1,000.00     | 1        | \$ 1,000.00   |
| 11       | Remove Existing Culvert                 | LSUM | \$2,000.00     | 1        | \$ 2,000.00   |
| 12       | Seeding                                 | LSUM | \$1,500.00     | 1        | \$ 1,500.00   |
| 12       | Pavement Marking                        | LSUM | \$20,000.00    | 1        | \$ 20,000.00  |
| 13       | Traffic Control                         | LSUM | \$20,000.00    | 1        | \$ 20,000.00  |

Subtotal Participating = \$ 341,950.00

**Total Participating = \$ 341,950.00**



**REQUEST FOR COMMISSION ACTION  
CITY OF INDEPENDENCE**

**April 23, 2026**

**Department Admin**

**Director Approval David Cowan**

**AGENDA ITEM** Consider setting the date of May 21, 2026 to receive demolition bids for structures previously condemned as dangerous and unsafe.

**SUMMARY RECOMMENDATION** City staff recommends setting the bid date.

**BACKGROUND** The City of Independence has approved the condemnation and removal of 24 houses and 1 medical office building. City staff is requesting that the Commission set May 21, 2026, at 2:00 pm to receive bids for the removal of these condemned structures.

**FINANCIAL INFORMATION** The cost of removal if the owner fails to commence removal prior to the award of the demolition contract.

**SUGGESTED MOTION** I move to set the date of May 21, 2026, at 2:00 pm to receive bids for the demolition of 25 structures previously condemned as dangerous and unsafe.

**SUPPORTING DOCUMENTS**

1. 2026 Demolition RFP Packet



# City of Independence, Kansas

## Request for Bid

### Demolition of Condemned Structures

---

Responses will be received at:

City of Independence  
2026 Demolition Packet  
120 N. 6<sup>th</sup> Street  
Independence, KS 67301

Email: [davids@independenceks.gov](mailto:davids@independenceks.gov)

Bids may be submitted by mail or hand delivery to the City Clerk. Electronic (email) submissions will not be accepted.

---

Questions regarding this Bid Packet  
Email: [davidc@independenceks.gov](mailto:davidc@independenceks.gov)  
Phone 620.332.2528

ADVERTISEMENT FOR BIDS



Sealed bids will be received by the City of Independence, Kansas, at the office of the City Clerk, 120 N. 6th Street, Independence, Kansas, until 2:00 p.m. on Thursday, May 21, 2026, at which time bids will be publicly opened and read aloud.

Contact: David Cowan | davidc@independenceks.gov | 620-332-2528

## SCOPE OF WORK

- The Contractor shall demolish and remove all structures, accessory buildings, and debris located on the designated properties. Demolition shall include the removal of all foundations, slabs, and footings. Existing public (pedestrian) sidewalks shall remain in place unless otherwise directed by the City.
- The Contractor shall clear each site of all vegetation, including shrubs, trees, and fencing, resulting in a clean and unobstructed lot.
- The Contractor shall be solely responsible for complying with all applicable federal, state, and local regulations regarding asbestos identification, handling, removal, and disposal.
- The Contractor shall transport and dispose of all demolition debris at a KDHE-approved landfill facility and shall comply with all Federal and State asbestos regulations. The City's demolition site shall not be used for disposal.
- The Contractor shall properly cap or plug all sewer lines using a watertight method. All work shall be subject to inspection and approval by the City.
- The Contractor shall, upon completion of demolition activities, backfill each site as necessary, grade it to match the surrounding contours, and seed it with grass to establish a stabilized surface.
- The Contractor shall be responsible for site safety and traffic control during all demolition activities.

## PROJECT LOCATIONS

- 1018 E. Birch Street
- 821 E. Maple Street
- 908 E. Maple Street
- 700 N. 12<sup>th</sup> Street
- 417 N. 2<sup>nd</sup> Street
- 509 N. 13<sup>th</sup> Street
- 1312 N. 10<sup>th</sup> Street
- 208 S. Earl Street
- 108 S. Wald Ave
- 214 S. 12<sup>th</sup> Street
- 1020 W. Chestnut Street
- 707 W. Cottonwood Street
- 828 W. Cottonwood Street
- 212 W. Laurel Street
- 1100 W. Laurel Street
- 720 W. Maple Street



- 805 W. Sycamore Street
- 917 W. Sycamore Street
- 800 W. Chestnut (medical office building)
- 705 Washington Street
- 733 Washington Street
- 300 Westminster Place
- 1014 W. Beech Street
- 1123 W. Main Street
- 1208 W. Myrtle Street

#### TIME OF COMPLETION

Work shall commence within fifteen (15) days of Notice to Proceed and be completed within sixty (60) days.

#### INSURANCE REQUIREMENTS

Contractor shall provide proof of General Liability Insurance and Workers' Compensation Insurance. A minimum of \$1,000,000 in liability coverage is required. The City shall be named as an additional insured.

#### ENVIRONMENTAL COMPLIANCE

The Contractor shall be solely responsible for identifying, testing, handling, abatement (if required), removal, transportation, and disposal of all asbestos-containing materials and any other hazardous or regulated materials associated with the demolition of the structures, in full compliance with all applicable federal, state, and local laws and regulations, including but not limited to KDHE and EPA requirements.

The Contractor shall obtain all required inspections, permits, and notifications prior to commencement of demolition activities, including any required asbestos inspections and filings with KDHE.

Documentation of such compliance, including inspection reports, notifications, and approvals, shall be provided to the City prior to demolition.

The Contractor agrees to indemnify, defend, and hold harmless the City, its officials, employees, and agents from and against any and all claims, damages, losses, fines, penalties, or regulatory actions arising out of or related to the Contractor's failure to comply with applicable environmental laws and regulations, including those related to asbestos or hazardous materials.

#### DISPOSAL REQUIREMENTS

All demolition materials shall be disposed of at KDHE-approved facilities. Asbestos materials shall be properly bagged (6 mil), labeled, and disposed of per regulations.

#### **Bid Rejection and Award**



The City of Independence, Kansas reserves the right to accept or reject any or all bids, to waive any informalities, irregularities, or technical defects in any bid, and to award the contract in the best interest of the City.

The City further reserves the right to reject any bid from a bidder who is determined, in the sole judgment of the City, to be unqualified, non-responsible, or otherwise unable to perform the work in accordance with the Contract Documents.

The City reserves the right to award the contract by individual property, by group of properties, or as a total project, whichever method is deemed most advantageous to the City.

The City may conduct such investigations as it deems necessary to determine the ability of the bidder to perform the work and may require the bidder to furnish additional information as requested.

The City reserves the right to reject any bid that is incomplete, conditional, or fails to comply with the requirements of the bid documents.

The City also reserves the right to delay the award of the contract for a reasonable period of time as may be necessary to evaluate bids and determine the lowest and best responsible bidder.

**SIGNATURE**

\_\_\_\_\_  
Contractor Signature

Date: \_\_\_\_\_

\_\_\_\_\_  
Name of Bidder (Printed)

\_\_\_\_\_  
Address

\_\_\_\_\_  
City, State, Zip

\_\_\_\_\_  
Signature

\_\_\_\_\_  
Date

\_\_\_\_\_  
Title

\_\_\_\_\_  
Contact Phone Number



**BID SCHEDULE**

**Alternative Bids Permitted:** A bidder may submit a bid on each individual property or may submit one bid for all the properties combined, or do both. When submitting a bid on all properties combined, the bidder must itemize the cost of demolition as to each property so the City can pass the cost on to the property owner as allowed by law.

**Individual Bids:**

- 1018 E. Birch Street \$ \_\_\_\_\_
- 821 E. Maple Street \$ \_\_\_\_\_
- 908 E. Maple Street \$ \_\_\_\_\_
- 700 N. 12<sup>th</sup> Street \$ \_\_\_\_\_
- 417 N. 2<sup>nd</sup> Street \$ \_\_\_\_\_
- 509 N. 13<sup>th</sup> Street \$ \_\_\_\_\_
- 1312 N. 10<sup>th</sup> Street \$ \_\_\_\_\_
- 208 S. Earl Street \$ \_\_\_\_\_
- 108 S. Wald Ave \$ \_\_\_\_\_
- 214 S. 12<sup>th</sup> Street \$ \_\_\_\_\_
- 1020 W. Chestnut Street \$ \_\_\_\_\_
- 707 W. Cottonwood Street \$ \_\_\_\_\_
- 828 W. Cottonwood Street \$ \_\_\_\_\_
- 212 W. Laurel Street \$ \_\_\_\_\_
- 1100 W. Laurel Street \$ \_\_\_\_\_
- 720 W. Maple Street \$ \_\_\_\_\_
- 805 W. Sycamore Street \$ \_\_\_\_\_
- 917 W. Sycamore Street \$ \_\_\_\_\_
- 800 W. Chestnut (medical office building) \$ \_\_\_\_\_
- 705 Washington Street \$ \_\_\_\_\_
- 733 Washington Street \$ \_\_\_\_\_
- 300 Westminster Place \$ \_\_\_\_\_
- 1014 W. Beech Street \$ \_\_\_\_\_
- 1123 W. Main Street (mult  
structures) \$ \_\_\_\_\_
- 1208 W. Myrtle Street \$ \_\_\_\_\_



**Combined Bid:**

*(If submitting a combined bid, the Contractor must provide an itemized cost per property. Failure to provide this breakdown at the time of contract execution may result in rejection of the award..)*

1. 1018 E. Birch Street
2. 821 E. Maple Street
3. 908 E. Maple Street
4. 700 N. 12<sup>th</sup> Street
5. 417 N. 2<sup>nd</sup> Street
6. 509 N. 13<sup>th</sup> Street
7. 1312 N. 10<sup>th</sup> Street
8. 208 S. Earl Street
9. 108 S. Wald Ave
10. 214 S. 12<sup>th</sup> Street
11. 1020 W. Chestnut Street
12. 707 W. Cottonwood Street
13. 828 W. Cottonwood Street
14. 212 W. Laurel Street
15. 1100 W. Laurel Street
16. 720 W. Maple Street
17. 805 W. Sycamore Street
18. 917 W. Sycamore Street
19. 800 W. Chestnut (medical office building)
20. 705 Washington Street
21. 733 Washington Street
22. 300 Westminster Place
23. 1014 W. Beech Street
24. 1123 W. Main Street (mult structures)
25. 1208 W. Myrtle Street

**Combined bid priced to remove and clear the lots for all (24) structures listed:**

• \$ \_\_\_\_\_

\*City will take any sandstone foundation stone and remove it from the site, when ready to be picked up, to be used at Riverside Park, if the bid winner desires.



*If a bidder improperly withdraws a bid or refuses to honor a bid that has been awarded by the City, the bidder shall not be eligible to bid on any City projects for a period of one (1) year thereafter.*

\_\_\_\_\_  
Name of Bidder (Printed)

\_\_\_\_\_  
Address

\_\_\_\_\_  
Signature

\_\_\_\_\_  
Date

\_\_\_\_\_  
Title

\_\_\_\_\_  
Contact Phone Number

\_\_\_\_\_  
Email



## STRUCTURE DEMOLITION SPECIFICATIONS

1. Demolition shall be the removal and disposal of the entire building, any outbuildings, concrete footers, slabs or any other associated structures at such locations as designated by the City. This shall also include all trees and any brush, vines or bushes, etc. necessary to clear lot.

NOTE: The contractor shall be responsible, at his own expense, for removing and disposing in the Montgomery County Landfill or other KDHE approved landfill site, any and all materials. (The City demolition site will not be used for this project.) This shall include but not be limited to paint cans, carpet, furniture, appliances, and other household trash as designated by the City.

2. Transite siding will be removed by hand, wetted and bagged (6 mil), and disposed of in an approved landfill in accordance with KDHE regulations. The contractor will not pulverize or otherwise crush asbestos siding and must remove by hand.
3. If required by the City prior to commencing work, the Contractor shall submit to the City a proposed method of operations for the removal and disposal of the structure(s). The schedule of coordination for shut-off, capping or discontinuation of utility services shall be submitted if so required by the City. Utilities may be left intact only by written request to the City by the owner of record prior to commencing work on the project.
4. Structures to be demolished shall be vacated and discontinued from use or inhabitation prior to commencing work. The Contractor shall cease work immediately and report the same to the City upon discovering either persons occupying the structure(s) for any reason or any other extenuating circumstances that would require action by the City or the owner before continuing demolition operations.
5. The City of Independence assumes no responsibility for the actual condition of the structures to be demolished. The Contractor shall satisfy himself through his own personal investigation of the structural conditions of the building.
6. The Contractor shall not be permitted to use any form of explosive devices or dispose of the materials by burning in the demolition of the structure(s) either at the site or any landfill.
7. The Contractor shall conduct the demolition and removal operations to ensure minimum interference with roads, streets, walks or other adjacent structures or facilities. Any damages caused by the demolition operations to adjacent structures, roads, streets, walks, personal property, etc. shall be repaired or otherwise compensated for by the Contractor at no expense to the City or additional change orders to the contract.
8. No street, sidewalk or other facilities shall be closed or otherwise obstructed for any length of time without written permission from the City prior to the Contractor commencing work. All authorities having jurisdiction over the affected facilities shall be notified by the Contractor no less than twenty-four (24) hours prior to commencing work.
9. If it is necessary to close or otherwise obstruct a street or walkway, the Contractor shall provide at his own expense an alternate route which shall be marked and guarded to ensure the safety of the



public. The plans for such alternate routes shall be approved by the City in writing prior to commencing work. Any barricades necessary for the protection of the public during the completion of the demolition operations shall be furnished and maintained by the Contractor. If said barricades are required to be in place overnight, adequate flashing warning lights shall be placed on the barricades to ensure nighttime visibility.

10. The Contractor shall provide safe passage to the public around the demolition area. Demolition operations shall be conducted to prevent damage to adjacent structures, facilities or operations and shall ensure the safety of the public from the demolition operations.
11. The City shall reserve the right to immediately suspend demolition operations upon finding a condition or situation which the City feels is unsafe for any reason. Work shall not continue until said situation or condition has been corrected in a manner acceptable to the City.
12. The Contractor shall provide at his own expense all interior and exterior shoring and bracing as needed to support, prevent movement, settlement or premature collapse of the structure to be demolished. Said support shall remain in place as long as necessary to provide safe conditions.
13. The Contractor shall promptly repair or cause repairs to be made to adjacent facilities or structures all damages caused by the demolition operations. Said costs incurred by the repairs shall be made by the Contractor at no cost to the City or owners of the adjacent property.
14. The Contractor shall furnish to the City written approval by the owners of said property that acceptable repairs or settlements have been made before final payment has been made and the Demolition Bond is returned.
15. The Contractor shall use water sprinkling, temporary enclosures or other suitable methods to ensure the lowest practical level of dust and dirt arising and scattering into the air. The Contractor shall comply with all regulations of all governmental agencies having jurisdiction over environmental protection as applies to building demolition operations.
16. White goods - air conditioners, refrigerators, freezers, stoves and ovens, microwave ovens, dishwashers, washers and dryers, water heaters, furnaces, televisions, and computers. Remove all items noted in this category and dispose of per Kansas Department of Health and Environment guidelines.
17. Household hazardous wastes - batteries, cleaning supplies, lawn & garden products, indoor pesticides, thermometers and medicines, automotive products, paints, other household chemicals shall be removed from the structure and disposed of at Montgomery County Household Hazardous Waste Department, County Barn, Independence, Kansas, on a daily basis.
18. Special waste-medical supplies, sharps, ammunition, medical waste, freezers and refrigerators that contain food. A special waste permit will be issued to the City for these items. Disposal shall be at an approved sanitary landfill.



19. Putrescible waste and household garbage - Canned goods, all food items and any other fast decomposing material that may be found in the structure to be demolished should be separated and taken to an approved sanitary landfill.
20. The Contractor shall demolish the structure completely, remove and dispose of all materials from the site. Such methods as required to safely complete the work in a workmanlike manner shall be employed within the confines of limitations of all governmental regulations concerning demolition operations.
21. Foundations and basement walls shall be demolished completely and disposed of off-site. Basement floors shall be removed or broken thoroughly to facilitate complete drainage at the Contractor's discretion providing the highest point of the floor remaining shall be a minimum of two (2) feet below the lowest point of the surface of the finished grade of the site.
22. All voids and below-grade areas resulting from the demolition operations shall be filled with non-organic materials approved by the City to ensure adequate drainage of the area.
23. Such materials shall consist of but not be limited to dirt with stone or other inorganic contents no more than six (6) inches at its widest dimension and free from debris. Trash, frozen materials, roots or other organic material shall not be permitted. The stone content of any fill material shall not exceed twenty-five (25) percent.
24. Prior to placing any fill material, the Contractor shall remove and dispose of all standing water, frost, frozen material, trash or debris.
25. Fill shall be placed in horizontal layers not to exceed six (6) inches in loose depth. Each layer shall be compacted with the fill material being maintained at an optimal moisture content to ensure a density equal to ninety (90) percent of the original adjacent undisturbed earth. If tests are required by City, the compaction tests shall be performed by a competent certified inspector at the expense of the Contractor.
26. The top one (1) foot of the fill area shall be topsoil only suitable for the growth of vegetation with no stone, sand, gravel or large organic material such as roots, stumps, etc.
27. After completing the fill placement, the Contractor shall grade the surface to meet adjacent contours to ensure proper drainage to the surrounding property or other surface drainage structures. Care shall be taken to prevent excess drainage upon adjacent property beyond that amount normally draining across the property prior to demolition. The Contractor shall place grass seed on the finished grade.
28. The Contractor shall remove all debris, rubbish or other materials resulting from the demolition operations from the site.
29. Materials suitable for fill as specified in Paragraph 12 from the immediate site may be stored on the site at the Contractor's discretion if there is available space. No burning of any material shall be permitted on site.



30. Materials, except as noted in Paragraph 1 above, from the demolition operations shall be transported by the Contractor from the demolition site and disposed of in a KDHE approved landfill. (The City demolition site will not be used for this project.)
31. The Contractor shall be responsible for discontinuing all utilities at the demolition site(s) at his own expense and the work required shall be completed as specified by each utility.
32. Sewer mains shall be capped or plugged with a watertight method which shall be inspected and approved by the City.
33. City water service shall be removed by the City at no expense to the Contractor. Any damage to said water service prior to the disconnection by the City shall be repaired at the expense of the Contractor.
34. Unless otherwise stated in the Contract Documents, the Contractor shall have salvage rights from the date of the Notice To Proceed to any and all materials remaining in the structures to be demolished.
35. In the event that the contract is let to multiple contractors, all contractors shall cooperate in the placing of the demolition material at the landfill site.



## STRUCTURE DEMOLITION

### SPECIAL CONDITIONS

#### LANDFILL SITE

1. All demolition materials, except as noted in Paragraph 1, Page 9 of the "Structure Demolition Specifications", shall be disposed of in a KDHE approved landfill site. **(The City demolition site will not be used for this project.)**
2. Transite siding will be removed by hand, wetted and bagged (6 ml), and disposed of in an approved landfill in accordance with KDHE regulations.
3. All labor, materials and equipment necessary for the demolition operations shall be furnished by the Contractor at no expense to the City.

#### HAULING

The Contractor shall ensure that all trucks used for the transportation of demolition materials shall not be overloaded to the point that debris will be lost on the haul road from the demolition site to the landfill area.

The Contractor shall check the haul route routinely during the daily demolition operation to ensure that no materials from the demolition site are on any public thoroughfare and immediately remove the same if any demolition material is found. A thorough cleaning of the haul route shall be completed at the end of the contract period and all demolition material shall be removed by the Contractor to the satisfaction of the City.

#### ORDINANCE NO. 4045

##### Section 1. Definitions

- A. "Water well" means any excavation that is drilled, cored, bored, washed, driven, jetted or otherwise constructed when the intended use of such excavation is for the location, diversion, artificial recharge or acquisition of groundwater.
- B. "Reconstructed water well" means existing water well that has been deepened or has had the casing replaced, repaired, added to or modified in any way for the purpose of obtaining groundwater.
- C. "Abandoned water well" means water well determined by the environmental officer of code enforcement officer of the City to be a well which:
  1. The use has been permanently discontinued;
  2. Pumping equipment has been permanently removed;



3. Is in such a state of disrepair that it cannot be used to supply water, or it has the potential for transmitting surface contaminants into the aquifer, or both;
4. Poses a potential health or safety hazard; or
5. Is in such a condition it cannot be placed in active or inactive status.

D. "Cistern" means a partially or entirely subterranean reservoir capable of water storage without water production capabilities.

## Section 2. Compliance

All water wells or cisterns must comply with all rules and regulations adopted by the State of Kansas and the City of Independence. All existing cisterns must be equipped with a workable pump and must be constructed so as to inhibit hazards or contamination, or must be abandoned.

## Section 3. Abandoned water wells

All abandoned water wells shall be plugged or caused to be plugged by the landowner in compliance with rules and regulations adopted by the State of Kansas and the City of Independence.

## Section 4. Cistern abandonment

Cistern abandonment must be completed by:

- A. Removal of water;
- B. Clear debris such as piping, hardware, non-masonry or stone materials from inside and around the site;
- C. Puncture the bottom so as to eliminate water retaining capabilities;
- D. Plug openings such as underground inlet pipes with concrete;
- E. Fill the entire interior areas of the cistern with sand, gravel or other clean inert granular material allowing for settlement; and
- F. Cover with a nonremovable lid.

1018 E. Birch



208 S. Earl



908 E. Maple



821 E. Maple



108 S. Wald



214 S. 12<sup>th</sup>



720 W. Maple



1123 W. Main – mult bldgs.



1100 W. Laurel



1020 W. Chestnut



828 W. Cottonwood



707 W. Cottonwood



805 W. Sycamore



917 W. Sycamore



700 N. 12<sup>th</sup>



509 N. 13<sup>th</sup>



212 W. Laurel



705 Washington St.



733 Washington



1312 N. 10<sup>th</sup> Street



300 Westminster Pl



417 N. 2<sup>nd</sup>



1014 W. Beech

Fire Damaged –



800 W. Chestnut – Medical Office Bldg



1208 W. Myrtle - Fire Damaged - Not Pictured



**REQUEST FOR COMMISSION ACTION  
CITY OF INDEPENDENCE**

**April 23, 2026**

**Department Admin**

**Director Approval David Cowan**

**AGENDA ITEM** Public Hearing to consider condemnation of 1028 W. Chestnut Street as dangerous and unsafe.

**SUMMARY RECOMMENDATION** City Staff recommends setting a Public Hearing date.

**BACKGROUND**

The property located at 1028 W. Chestnut Street has previously been reported to the City for concerns related to the condition of the primary structure, occupancy without utilities, and environmental issues.

The Building Inspector reports: *“The foundation has been repaired and appears to be in good condition. However, the remainder of the house is largely unchanged, with missing siding and the roof in poor condition.”*

At a previous meeting, Lisa Drumeller reported that Indy Heat and Air is installing a heating system. Additional work includes clearing vegetation, removing exterior trash and debris, installing windows, and completing interior finishes and repairs.

The property owner is requesting additional time to complete the project.

**FINANCIAL INFORMATION** The cost of removal if the owner fails to commence repair or removal of the structure

**SUGGESTED MOTION** I move to adjourn the Public Hearing for the condemnation of 1028 W Chestnut Street until July 23, 2026 at 5:30 p.m.

**SUPPORTING DOCUMENTS**

1. 04172026 Photo
2. 1028 W. Chestnut - Photos
3. Notes & Parcel - 1028 W Chestnut
4. 3159933\_OE\_Report
5. 2025-079 - Condemnation - P\_H - 1028 W Chestnut



# 1028 W. Chestnut

---

# 1028 W. Chestnut



Address: 10290 W Chestnut

Utility Account: Y  N  
Last Active Service Date: 9/15/2020  
Parcel:  Y N Pictures: Structure-House-Yard-Sides-Rear-Rear Yard  
Holes in Roof: Y N

Notes: Roof in poor condition

Missing Windows:  Y N  
Notes: Missing, broken, boarded

Open Doors:  Y N  
Notes: Front door open

Yard ~~Not~~ Mowed:  Y N Trash or Debris: Y  N  
Notes: Yard kept

Other Notes: Porch, foundation, roof in disrepair  
Squatters, house & garage

Print Page

These Links May Require Adobe Acrobat Reader, Click [here](#) to Download it.

[View Sketch](#) --- [Back to Search Page](#) --- [Home](#)

**The Parcel Number for this Property is 063-087-25-0-30-13-024.00-0**  
**Quick Ref ID: 3006**

**Owner Information**

|                   |                                   |
|-------------------|-----------------------------------|
| <b>Owner Name</b> | STEADFAST PROPERTIES, LLC         |
| <b>Address</b>    | PO BOX 183 INDEPENDENCE, KS 67301 |

**Property Situs Address**

|                |  |
|----------------|--|
| <b>Address</b> | 1028 W CHESTNUT ST, Independence, KS 67301 |
|----------------|--|

**Land Based Classification System**

|                  |                                    |
|------------------|------------------------------------|
| <b>Function</b>  | Single family residence (detached) |
| <b>Activity</b>  | Household activities               |
| <b>Ownership</b> | Private-fee simple                 |
| <b>Site</b>      | Developed site - with buildings    |

**General Property Information**

|                       |                 |
|-----------------------|-----------------|
| <b>Prop Class</b>     | Residential - R |
| <b>Living Units</b>   | 1               |
| <b>Zoning</b>         |                 |
| <b>Neighborhood</b>   | 108.F           |
| <b>Tax Unit Group</b> | 108             |

**Property Factors**

|                          |                          |
|--------------------------|--------------------------|
| <b>Topography</b>        | Level - 1                |
| <b>Utilities</b>         | All Public - 1           |
| <b>Access</b>            | Paved Road - 1           |
| <b>Fronting</b>          | Residential Street - 4   |
| <b>Location</b>          | Neighborhood or Spot - 6 |
| <b>Parking Type</b>      | On and Off Street - 3    |
| <b>Parking Quantity</b>  | Adequate - 2             |
| <b>Parking Proximity</b> | On Site - 3              |
| <b>Parking Covered</b>   |                          |
| <b>Parking Uncovered</b> |                          |

**2025 Appraised Value**

| Class           | Land         | Building     | Total        |
|-----------------|--------------|--------------|--------------|
| Residential - R | 4,680        | 4,560        | 9,240        |
| <b>Total</b>    | <b>4,680</b> | <b>4,560</b> | <b>9,240</b> |

**2024 Appraised Value**

| Class           | Land         | Building     | Total        |
|-----------------|--------------|--------------|--------------|
| Residential - R | 4,680        | 4,040        | 8,720        |
| <b>Total</b>    | <b>4,680</b> | <b>4,040</b> | <b>8,720</b> |

**Tract Description**

SISSON & BRUBAKER ADD, S25, T32, R15, BEG NE COR LT 17 S 180' W 48' N 180' E 48' TO POB; LOT WIDTH: 048.0 LOT DEPTH: 180.0 Plat Book/Page 1 /16 Deed Book/Page 698 /561 628 /857 454 /320 315 /302

**Deed Information**

| Book1 | Page1 | Book2 | Page2 | Book3 | Page3 | Book4 | Page4 |
|-------|-------|-------|-------|-------|-------|-------|-------|
| 698   | 561   | 628   | 857   | 698   | 561   |       |       |

**Market Land Information**

| Method | Type             | AC/SF | Eff FF | Depth | D-Fact | Inf1 | Fact1 | Inf2 | Fact2 | Ovrd | Class | Value Est |
|--------|------------------|-------|--------|-------|--------|------|-------|------|-------|------|-------|-----------|
| Sqft   | Primary Site - 1 | 8640  |        |       |        |      |       |      |       |      |       | 4,680     |

**Dwelling Information**

| Dwelling Information         |                         | Comp Sales Information |           |
|------------------------------|-------------------------|------------------------|-----------|
| Res Type                     | Single-family Residence | Arch Style             | Bungalow  |
| Quality                      | FR                      | Bsmt Type              | Crawl - 2 |
| Year Built                   | 1905                    | Total Rooms            | 4         |
| Eff Year                     |                         | Bedrooms               | 2         |
| MS Style                     | One Story               | Family Rooms           |           |
| LBCSStruct                   | Detached SFR unit       | Full Baths             | 1         |
| No. of Units                 |                         | Half Baths             |           |
| Total Living Area            |                         | Garage Cap             |           |
| Calculated Area              | 1,098                   | Foundation             | Block - 3 |
| Main Floor Living Area       | 1,098                   |                        |           |
| Upper Floor Living Area Pct. |                         |                        |           |
| CDU                          | VP                      |                        |           |
| Phys/Func/Econ               | VP/ /                   |                        |           |
| Ovr Pct Gd/RCN               | /130,180                |                        |           |
| Remodel                      |                         |                        |           |
| Percent Complete             |                         |                        |           |
| Assessment Class             |                         |                        |           |
| MU Cls/Pct                   |                         |                        |           |

**Dwelling Components**

| Code                                    | Units | Pct | Quality | Year |
|---|-------|-----|---------|------|
| Wood Deck (SF) with Roof                | 32    |     |         |      |
| Composition Shingle                     |       | 100 |         |      |
| Floor Furnace                           |       | 100 |         |      |
| Plumbing Rough-ins (#)                  | 1     |     |         |      |
| Enclosed Wood Deck (SF), Screened Walls | 104   |     |         |      |
| Frame, Siding/Shingle                   |       | 100 |         |      |
| Raised Subfloor (% or SF)               |       | 100 |         |      |
| Plumbing Fixtures (#)                   | 5     |     |         |      |
| Automatic Floor Cover Allowance         |       |     |         |      |

**Building Improvements**

| Id | Occupancy                     | MSCls | Rank | Qty | Yr Bld | Eff Yr | LBCS | Area | Perim | Hgt | Dimensions | Stories | Phys | Func | Econ | OVR% | Rsn | Cls | RCN    | %Gd | Value |
|----|-------------------------------|-------|------|-----|--------|--------|------|------|-------|-----|------------|---------|------|------|------|------|-----|-----|--------|-----|-------|
| 86 | Residential Garage - Detached | D     | 1.00 | 1   | 1960   |        |      | 360  | 76    | 8   | 20 X 18    | 1       | 1    | 1    |      |      |     |     | 11,910 | 2   | 240   |

These Links May Require Adobe Acrobat Reader, Click [here](#) to Download it.

[View Sketch](#) --- [Back to Search Page](#) --- [Home](#)

## Report Cover Page

|                 |   |                   |   |
|-----------------|---|-------------------|---|
| Date:           | <b>11/24/2025</b>   | Prepared For:     | <b>City of Independence</b>                           |
| Order No.:      | <b>3159933</b>  | Owner(s):         | <b>Steadfast Properties, LLC</b>                      |
| Issuing Office: | <b>Security 1st Title<br/>114 N. Pennsylvania Avenue<br/>Independence, KS 67301</b> | Property Address: | <b>1028 W Chestnut St, Independence,<br/>KS 67301</b> |

**Note:** The documents linked in this report should be reviewed carefully. These documents, such as covenants conditions and restrictions, may affect the title, ownership and use of the property. You may wish to engage legal assistance in order to fully understand and be aware of the implications of the effect of these documents on your property.

### Tax Information:

[087-25-0-30-13-024.00-0](#)

Date: November 24, 2025

Property Address: 1028 W Chestnut St, Independence, KS  
67301

File No.: 3159933

Title Contact: Mary Jo Wallis

Contact E-mail: mwallis@security1st.com

## OWNERS AND ENCUMBRANCES REPORT

For the exclusive use of:

City of Independence

David Cowan

120 N. 6th Street

Independence, KS 67301

Effective Date of this Report: November 06, 2025 at 7:00 A.M.

On Real Estate described as:

**Beginning at the Northeast corner of Lot 17, Sisson and Brubaker's Addition to the City of Independence, South 180 feet, West 48 feet, North 180 feet, East 48 feet to beginning, Independence, Montgomery County, Kansas**

The Public Records located in Montgomery County indicate that:

A. Interest in the Land described in this Report is owned, at the Report Effective Date, by:

Steadfast Properties, LLC

B. The Real Estate is encumbered by the following Mortgages, Federal Tax Liens, State Tax Liens, Bankruptcies, and Judgments:

1. The County Tax Records indicated that the real estate taxes are:

General taxes and special assessments for the year 2025 in the amount of \$173.18, NOT PAID.

Tax Parcel No. # 087-25-0-30-13-024-00-0-01

PIN # IC 3115

This Report is limited to only the information described above.

This Report is not nor is to be construed as, an Abstract of Title, Title Opinion, or Title Insurance Policy.

The total liability of this Company by reason of losses and damages that may occur by reason of any errors and omissions in this Company's report is limited to the fee it received for the preparation and issuance of this report.

Security 1st Title

*Mary Jo Wallis*

Licensed Abstracter



State of Kansas, Montgomery County  
 This instrument was filed for  
 Record on December 15, 2025 8:45 AM  
 Recorded in Book 752 Page 1341- 1341  
 Fee: \$0.00 202503921



*Marilyn Calhoun*  
 Marilyn Calhoun, Register of Deeds

**RESOLUTION NO. 2025-079**

A RESOLUTION FIXING A TIME AND PLACE AND PROVIDING FOR NOTICE OF HEARING BEFORE THE GOVERNING BODY OF THE CITY OF INDEPENDENCE, KANSAS, OF WHICH OWNERS, OWNERS AGENTS, LIEN HOLDERS OF RECORD AND ANY OCCUPANTS, IF ANY, OF THE STRUCTURE OR STRUCTURES IDENTIFIED BELOW, IN SAID CITY MAY APPEAR AND SHOW CAUSE WHY SAID STRUCTURE OR STRUCTURES SHOULD NOT BE CONDEMNED AND ORDERED REPAIRED OR DEMOLISHED PURSUANT TO K.S.A. 12-1751 ET. SEQ.

WHEREAS, the enforcing officer of the City of Independence, Kansas, did on the 11<sup>th</sup> day of December 2025, file with the Governing body of said City, statements, and reports in writing that the structure or structures located on said properties hereinafter described are unsafe and/or dangerous:

✓ **Legal:** Beginning at the Northeast corner of Lot 17, South 180 feet, West 48 feet, North 180 feet, East 48 feet to beginning, Sisson and Brubaker's Addition to the City of Independence, Montgomery County, Kansas.

**Common Address:** 1028 W Chestnut St.

**Mortgage:**

NOW, THEREFORE, be it resolved by the Governing Body of the City of Independence, Kansas:

That a public hearing will be held on Thursday, **February 26, 2026** before the Governing Body of the City of Independence, Kansas, at **5:30 p.m.**, in City Hall, 120 N. 6<sup>th</sup> Street, Independence, Kansas, at which time the owner, the owners agent, any lien holders of record and any occupant of the structure or structures located on the properties described herein, may appear and show cause why such structure or structures should not be condemned as unsafe and/or dangerous and ordered repaired or removed.

Be it further resolved that the City Clerk shall cause this Resolution to be published one time each week for two consecutive weeks on the same day of each week, that at least thirty (30) days shall elapse between the last publication and the date set for hearing and the City Clerk shall give notice of the aforesaid hearing in the manner provided by Ordinance and by law.

Be it further resolved by the Governing Body of the City of Independence that its authority for the actions set forth herein is established pursuant to K.S.A. 12-1751 ET. SEQ.

Adopted this 11th day of December 2025.

*W. J. Smith*  
 \_\_\_\_\_  
 Mayor

*David Schuman*  
 \_\_\_\_\_  
 City Clerk

(SEAL)





**REQUEST FOR COMMISSION ACTION  
CITY OF INDEPENDENCE  
April 23, 2026**

**Department Admin**

**Director Approval David Cowan**

**AGENDA ITEM** Consider a resolution to rescind the condemnation action of 620 W. Chestnut Street.

**SUMMARY RECOMMENDATION** City staff recommends the City Commission rescind the condemnation of 620 W. Chestnut Street.

**BACKGROUND**

The property located at 620 W. Chestnut was previously reported by a tenant for foundation issues, and condemnation proceedings were initiated after the owner declined to make the necessary repairs. The property has since been sold to a new owner, who engaged Joyco Property Management to complete rehabilitation of the home.

The foundation issues have been addressed, and the structure's interior has successfully passed inspection. It is now being offered for sale by the current owner.

Based on these improvements, City staff recommends that the Commission adopt a resolution rescinding the condemnation in order to clear the title.

**FINANCIAL INFORMATION** N/A

**SUGGESTED MOTION** I move to adopt a resolution rescinding previous resolutions which set a hearing date to consider the condemnation of 620 W. Chestnut Street as dangerous and unsafe.

**SUPPORTING DOCUMENTS**

1. RESOLUTION 2026-054 - RESCIND CONDEMNATION -620 W Chestnut
2. April 02 2026

**RESOLUTION NO. 2026-054**

A RESOLUTION RESCINDING A PREVIOUS RESOLUTION WHICH SET A HEARING DATE TO CONSIDER CONDEMNATION

WHEREAS, the Governing Body of the City of Independence, Kansas, previously adopted a resolution setting a hearing to consider condemning certain property located within the City as being dangerous and unsafe;

AND WHEREAS, the owner of said property has taken steps to make repairs and/or improvements to the property.

NOW, THEREFORE, be it resolved by the Governing Body of the City of Independence, Kansas:

The resolution setting a hearing to consider condemning the following described property as being dangerous and unsafe is hereby rescinded and the property is released from all condemnation proceedings:

Legal Description

The West 45 feet of Lots 6 and 7, Block 12, Original City of Independence, Montgomery County, Kansas.

Common Address

620 W Chestnut St.

Mortgage

Adopted this 23<sup>rd</sup> day of April, 2026.

(SEAL)

---

Mayor

---

City Clerk



# 620 W. Chestnut

---



# 620 W. Chestnut

---



**REQUEST FOR COMMISSION ACTION  
CITY OF INDEPENDENCE  
April 23, 2026**

**Department Admin**

**Director Approval David Cowan**

**AGENDA ITEM** Consider setting the date of June 25, 2026, for a Public Hearing to consider the condemnation of 1208 W. Myrtle as dangerous and unsafe.

**SUMMARY RECOMMENDATION** City Staff recommends setting the date.

**BACKGROUND**

On April 15, 2026, the residential structure located at 1208 W. Myrtle sustained significant fire damage, resulting in extensive damage to both the interior and exterior of the home. As a result, the structure is currently uninhabitable.

City staff were contacted the following day by Lisa Druemeller regarding the property. The owner, Hannah's House, carries insurance through the Kansas Fair Plan. An adjuster has inspected the property and determined it to be a total loss.

City staff explained the condemnation process, and Ms. Druemeller has agreed to sign a release allowing the structure to be included in the City's current demolition bid for removal. Staff has also sent correspondence requesting the City's share of the insurance proceeds to cover demolition costs.

City staff recommends setting June 25, 2026, at 3:30 p.m. as the date for a public hearing to consider the condemnation of the structure at 1208 W. Myrtle as dangerous and unsafe.

**FINANCIAL INFORMATION** The cost of removal if the owner fails to commence repair or removal of the structure.

**SUGGESTED MOTION** I move to adopt a resolution setting the date of June 25, 2026, at 3:30 pm for a Public Hearing to consider the condemnation of 1208 W. Myrtle Street as dangerous and unsafe.

**SUPPORTING DOCUMENTS**

1. RESOLUTION 2026-055 - CONDEMNATION - PH - 1208 W Myrtle
2. 04172026 Photo
3. Photo 1208 W. Myrtle
4. 2026 -1208 W Myrtle - Setting Date of Public Hearing
5. Parcel

**RESOLUTION NO. 2026-055**

A RESOLUTION FIXING A TIME AND PLACE AND PROVIDING FOR NOTICE OF HEARING BEFORE THE GOVERNING BODY OF THE CITY OF INDEPENDENCE, KANSAS, OF WHICH OWNERS, OWNERS AGENTS, LIEN HOLDERS OF RECORD AND ANY OCCUPANTS, IF ANY, OF THE STRUCTURE OR STRUCTURES IDENTIFIED BELOW, IN SAID CITY MAY APPEAR AND SHOW CAUSE WHY SAID STRUCTURE OR STRUCTURES SHOULD NOT BE CONDEMNED AND ORDERED REPAIRED OR DEMOLISHED PURSUANT TO K.S.A. 12-1751 ET. SEQ.

WHEREAS, the enforcing officer of the City of Independence, Kansas, did on the 23<sup>rd</sup> day of April 2026, file with the Governing body of said City, statements, and reports in writing that the structure or structures located on said properties hereinafter described are unsafe and/or dangerous:

**Legal:** Lot 1, Beginning at the Southeast Corner 75' west, then 140' North, then 75' East, then South to Point of Beginning, Westside Addition to the City of Independence, Montgomery County, Kansas.

**Common Address:** 1208 W Myrtle St.

**Mortgage:**

NOW, THEREFORE, be it resolved by the Governing Body of the City of Independence, Kansas:

That a public hearing will be held on Thursday, **June 25, 2026** before the Governing Body of the City of Independence, Kansas, at **5:30 p.m.**, in City Hall, 120 N. 6<sup>th</sup> Street, Independence, Kansas, at which time the owner, the owners agent, any lien holders of record and any occupant of the structure or structures located on the properties described herein, may appear and show cause why such structure or structures should not be condemned as unsafe and/or dangerous and ordered repaired or removed.

Be it further resolved that the City Clerk shall cause this Resolution to be published one time each week for two consecutive weeks on the same day of each week, that at least thirty (30) days shall elapse between the last publication and the date set for hearing and the City Clerk shall give notice of the aforesaid hearing in the manner provided by Ordinance and by law.

Be it further resolved by the Governing Body of the City of Independence that its authority for the actions set forth herein is established pursuant to K.S.A. 12-1751 ET. SEQ.

Adopted this 23<sup>rd</sup> day of April 2026.

(SEAL)

\_\_\_\_\_  
Mayor

\_\_\_\_\_  
City Clerk



# 1208 W. Myrtle

---

# 1208 W. Myrtle

---





**CITY OF INDEPENDENCE, KANSAS**

**Office of the Building Official**

120 N. 6<sup>th</sup> Street • Independence, KS 67301

Phone: (620) 332-2528 • Email: davidc@independenceks.gov

---

**Date:** 04/15/2026

**To:**

**Hannah's House Ministries, Inc**

**PO Box 176**

Independence, Kansas 67301

---

**RE:** Notice of Setting a Date for a Public Hearing to Consider Condemnation of Property

**Property Location: 1208 W. Myrtle**

**Lien Holder:**

Dear Hannah's House:

On **April 23, 2026**, pursuant to **K.S.A. 12-1752**, the enforcing officer for the City of Independence, Kansas, will request that the **City Commission** set a **public hearing date** to consider whether the structure(s) located at **1208 W. Myrtle Street** are unsafe or dangerous, and whether they should be ordered by the Governing Body to be repaired or demolished.

The structure was involved in a fire on April 15, 2026, at 12:17 am which did extensive damage to the attic, roof, 2<sup>nd</sup> floor and water damage to the structure, making it uninhabitable.

To avert condemnation proceedings for the above-referenced property, it is imperative that the following actions be undertaken **without delay**:

1. **Mortgage/Lien Holder Information** – Provide the City with the current mortgage or lien holder and insurance information.
2. **Structural Repair** – If you intend to repair the structure, submit a **detailed plan and timeline** outlining the steps you will take to restore the building to a safe and usable condition.
3. **Property Maintenance** – Maintain the property in accordance with City Code, including **regular mowing, trimming of vegetation, and removal of all trash and debris.**



“Delivering Excellence”

4. **Demolition Procedures** – If you choose to demolish the structure, begin the process immediately and provide the City with a **timeline for demolition and site clearance**. A **City-issued demolition permit** is required prior to any such work.

**Commission Meeting – Setting the Date:**

- **Date:** April 23, 2026
- **Time:** 5:30 PM
- **Location:** 120 N. 6<sup>th</sup> – Commission Meeting Room 1<sup>st</sup> Floor

Should you need clarification or wish to discuss this matter further, please contact me at your convenience at **(620) 332-2528** (office), **(620) 330-0056** (mobile), or via email at **dauidc@independenceks.gov**.

Your prompt cooperation in addressing this matter is appreciated.

Sincerely,

**David J. Cowan**

Assistant City Manager

Building Official / Director

City of Independence, Kansas

Print Page

These Links May Require Adobe Acrobat Reader, Click [here](#) to Download it.

[View Sketch](#) --- [Back to Search Page](#) --- [Home](#)

**The Parcel Number for this Property is 063-087-36-0-20-02-020.00-0**  
**Quick Ref ID: 4212**

**Owner Information**

|                   |                                   |
|-------------------|-----------------------------------|
| <b>Owner Name</b> | HANNAH'S HOUSE MINISTRIES, INC    |
| <b>Address</b>    | PO BOX 176 INDEPENDENCE, KS 67301 |

**Property Situs Address**

|                |  |
|----------------|--|
| <b>Address</b> | 1208 W MYRTLE ST, Independence, KS 67301 |
|----------------|--|

**Land Based Classification System**

|                  |                                    |
|------------------|------------------------------------|
| <b>Function</b>  | Single family residence (detached) |
| <b>Activity</b>  | Household activities               |
| <b>Ownership</b> | Private-fee simple                 |
| <b>Site</b>      | Developed site - with buildings    |

**General Property Information**

|                       |            |
|-----------------------|------------|
| <b>Prop Class</b>     | Exempt - E |
| <b>Living Units</b>   | 1          |
| <b>Zoning</b>         |            |
| <b>Neighborhood</b>   | 108.F      |
| <b>Tax Unit Group</b> | 108        |

**Property Factors**

|                          |                          |
|--------------------------|--------------------------|
| <b>Topography</b>        | Level - 1                |
| <b>Utilities</b>         | All Public - 1           |
| <b>Access</b>            | Paved Road - 1 Alley - 7 |
| <b>Fronting</b>          | Residential Street - 4   |
| <b>Location</b>          | Neighborhood or Spot - 6 |
| <b>Parking Type</b>      | On and Off Street - 3    |
| <b>Parking Quantity</b>  | Adequate - 2             |
| <b>Parking Proximity</b> | On Site - 3              |
| <b>Parking Covered</b>   |                          |
| <b>Parking Uncovered</b> |                          |

**2026 Appraised Value**

| Class        | Land         | Building      | Total         |
|--------------|--------------|---------------|---------------|
| Exempt - E   | 2,520        | 20,270        | 22,790        |
| <b>Total</b> | <b>2,520</b> | <b>20,270</b> | <b>22,790</b> |

**2025 Appraised Value**

| Class        | Land         | Building      | Total         |
|--------------|--------------|---------------|---------------|
| Exempt - E   | 2,520        | 19,610        | 22,130        |
| <b>Total</b> | <b>2,520</b> | <b>19,610</b> | <b>22,130</b> |

**Tract Description**

WESTSIDE ADD, S36, T32, R15, BG SE COR LT 1 W 75' N 140' E 75' S TO POB; Lot Width: 075.0 Lot Depth: 140.0 Plat Book/Page A /3 Deed Book/Page 684 /526 378 /342 369 /020

**Deed Information**

| Book1 | Page1 | Book2 | Page2 | Book3 | Page3 | Book4 | Page4 |
|-------|-------|-------|-------|-------|-------|-------|-------|
| 684   | 526   | 684   | 526   |       |       |       |       |

**Market Land Information**

| Method | Type             | AC/SF | Eff FF | Depth | D-Fact | Inf1 | Fact1 | Inf2 | Fact2 | Ovrd | Class | Value Est |
|--------|------------------|-------|--------|-------|--------|------|-------|------|-------|------|-------|-----------|
| Sqft   | Primary Site - 1 | 10500 |        |       |        | 8    | 50    |      |       |      |       | 2,520     |

**Dwelling Information**

| Dwelling Information         |                         | Comp Sales Information |              |
|------------------------------|-------------------------|------------------------|--------------|
| Res Type                     | Single-family Residence | Arch Style             | Bungalow     |
| Quality                      | AV                      | Bsmt Type              | Full - 4     |
| Year Built                   | 1915                    | Total Rooms            | 7            |
| Eff Year                     |                         | Bedrooms               | 3            |
| MS Style                     | 1 1/2 Story Finished    | Family Rooms           |              |
| LBCSStruct                   | Detached SFR unit       | Full Baths             | 2            |
| No. of Units                 |                         | Half Baths             |              |
| Total Living Area            |                         | Garage Cap             |              |
| Calculated Area              | 1,488                   | Foundation             | Concrete - 2 |
| Main Floor Living Area       | 1,026                   |                        |              |
| Upper Floor Living Area Pct. | 45                      |                        |              |
| CDU                          | FR                      |                        |              |
| Phys/Func/Econ               | PR/ /                   |                        |              |
| Ovr Pct Gd/RCN               | /206,100                |                        |              |
| Remodel                      |                         |                        |              |
| Percent Complete             |                         |                        |              |
| Assessment Class             |                         |                        |              |
| MU Cls/Pct                   |                         |                        |              |

**Dwelling Components**

| Code                             | Units | Pct | Quality | Year |
|----------------------------------|-------|-----|---------|------|
| Veneer, Brick                    |       | 100 |         |      |
| Total Basement Area (SF)         | 1,008 |     |         |      |
| Wall Furnace                     |       | 100 |         |      |
| Plumbing Rough-ins (#)           | 1     |     |         |      |
| Open Slab Porch (SF)             | 270   |     | 2       | 1950 |
| Raised Slab Porch (SF) with Roof | 224   |     |         |      |
| Composition Shingle              |       | 100 |         |      |
| Raised Subfloor (% or SF)        |       | 100 |         |      |
| Plumbing Fixtures (#)            | 9     |     |         |      |
| Automatic Floor Cover Allowance  |       |     |         |      |

**Building Improvements**

| Id | Occupancy                     | MSCIs | Rank | Qty | Yr Blt | Eff Yr | LBCS | Area | Perim | Hgt | Dimensions | Stories | Phys | Func | Econ | OVR% | Rsn | ClS | RCN    | %Gd | Value |
|----|-------------------------------|-------|------|-----|--------|--------|------|------|-------|-----|------------|---------|------|------|------|------|-----|-----|--------|-----|-------|
| 95 | Residential Garage - Detached | D     | 2.00 | 1   | 1960   |        |      | 320  | 72    | 8   | 20 X 16    | 1       | 1.5  | 2    |      |      |     |     | 15,200 | 6   | 910   |

These Links May Require Adobe Acrobat Reader, Click [here](#) to Download it.

[View Sketch](#) --- [Back to Search Page](#) --- [Home](#)



**REQUEST FOR COMMISSION ACTION  
CITY OF INDEPENDENCE**

**April 23, 2026**

**Department Admin**

**Director Approval David Cowan, John Garris**

**AGENDA ITEM** Consider approving a 20-minute parking stall at 305 E. Main Street.

**SUMMARY RECOMMENDATION** City staff recommends approving a 20-minute stall on East Main Street.

**BACKGROUND**

City staff was contacted by the owner of Cornerstone Glass Company, located at 305 E. Main Street, regarding ongoing parking concerns affecting his business. The owner reports limited customer access due to employee parking from the adjacent daycare to the east.

To address these challenges, the owner is requesting the installation of a time-limited parking stall to provide customers with convenient access for dropping off and picking up glass items associated with his business operations.

**FINANCIAL INFORMATION** The Street Department will install and update the signage at a cost of \$500.00.

**SUGGESTED MOTION** I move to approve (1) 20-minute parking stall on the south side of Main Street in the first stall in the 300 block of East Main Street.

**SUPPORTING DOCUMENTS**

1. 305 E. Main
2. CGC Parking Stall Request

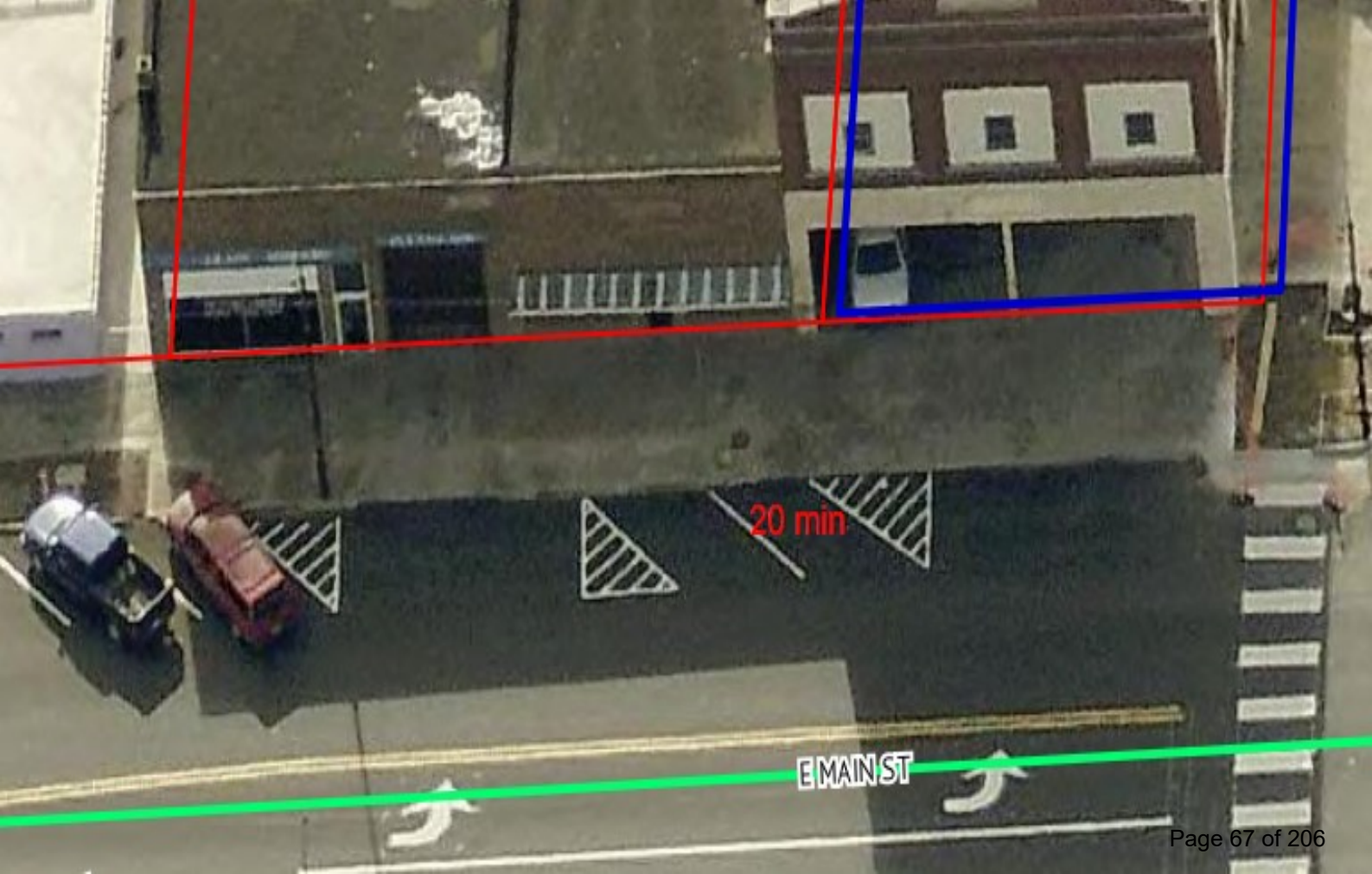

20 min

E MAIN ST

Good afternoon, David!

I'm having issues with the daycare center that is next to our shop, allowing their employees to take up all of our customer parking every day. I called, but they didn't answer. I have left a voicemail asking that they park further down or across the street, but that has not done any good either. I'm trying to avoid an in person altercation.

Is there any way we could get either Cornerstone Glass Parking Only, or 15-minute parking signs in at least 2 of our 3 parking spots in front of our building? We have walk in customers that bring us windows and things to fix, then pick them up. We're having to carry those items half a block down due to them always occupying our parking spots all day.

Let me know what can be done. Thank you in advance for any help!

Perry Daily  
Owner/Operations Manager  
Cornerstone Glass Company, LLC  
305 E. Main St.  
Independence, KS. 67301  
(620) 331-2752



Cornerstone  
Glass  
Company L.L.C.



**REQUEST FOR COMMISSION ACTION  
CITY OF INDEPENDENCE  
April 23, 2026**

**Department Admin**

**Director Approval David Cowan**

**AGENDA ITEM** Consider a request regarding ADA complaint related to accessibility access.

**SUMMARY RECOMMENDATION** City staff recommends paying 50% of the cost.

**BACKGROUND**

The City of Independence received a complaint in January 2026 from a disabled resident who utilizes a motorized scooter. The resident reported that the accessible route from 401 S. Penn to downtown was not compliant, resulting in several accidents while using his scooter. City staff reviewed the concern and initiated corrective actions, including the installation of an ADA ramp at the northwest corner of Pennsylvania and Walnut.

Staff also identified four locations between Walnut and Main Street that were in violation of City Code Sec. 94-94 related to raised sidewalks. Notification letters were sent to the respective property owners on January 14, 2026, providing 60 days to complete the necessary repairs. To date, two property owners have responded—one has completed repairs, and the other is exploring assistance options due to approximately 54 feet of sidewalk damage caused by tree roots originating in the public right-of-way.

Staff has evaluated existing programs and noted that the current sidewalk program remains unfunded. Additionally, recent strategic planning discussions highlighted widespread community concerns regarding aging sidewalks and damage caused by tree roots. Staff is developing a new program to address these localized issues, as well as broader sidewalk repair needs, and will present it to the Commission during the upcoming budget process.

To address the immediate complaint, staff recommends proceeding in accordance with City Code by initiating condemnation of the non-compliant sidewalks that remain unrepaired and completing the necessary work. The estimated cost for the remaining three repairs is \$7,000, which would typically be assessed to the property owners. However, staff recommends that the City cover 50% of the repair costs and bill the property owners for the remaining balance. Staff also recommends reimbursing the property owner who has already completed repairs for 50% of their eligible costs.

City staff will contact the remaining property owners prior to the next Commission meeting to determine whether they are willing to complete the repairs with the proposed 50% cost share, in lieu of proceeding with condemnation.

Estimated cost is based on the City contract for concrete work.

| L  | W | SY | Bid Price |            |
|----|---|----|-----------|------------|
| 54 | 6 | 36 | \$ 125.00 | \$4,500.00 |
| 24 | 6 | 16 | \$ 125.00 | \$2,000.00 |
| 6  | 6 | 4  | \$ 125.00 | \$ 500.00  |

**FINANCIAL INFORMATION** Expenditure from remaining ADA funds of a maximum of \$7,000.00 to make repairs and \$900.00 to reimburse for work already done.

**SUGGESTED MOTION** I move to authorize staff to proceed with condemnation and repair of the non-compliant sidewalks, and to provide a cost-share incentive whereby the City will cover 50% of the repair costs.

**SUPPORTING DOCUMENTS**

1. 311 S. Penn - Pic 1
2. 101 W. Maple - Pic 1
3. 207 S. Penn - Pic 1
4. 219 S. Penn - Pic 1



2026/01/13 14:20



2026/01/13 14:17



2026/01/13 14:18



2026/01/13 14:19



**REQUEST FOR COMMISSION ACTION  
CITY OF INDEPENDENCE**

**April 23, 2026**

**Department Zoning Administration**

**Director Approval Kayla Schabel**

**AGENDA ITEM** Consider recommendation from the Planning Commission to amend the zoning code and adopt a landscaping ordinance.

**SUMMARY RECOMMENDATION** Approve the adoption of Article XIX, Landscaping Regulations, as recommended by the Planning Commission.

**BACKGROUND**

During the 2025 zoning code update, the originally proposed landscaping article was not adopted due to concerns with complexity and applicability to Independence.

Staff prepared a revised draft with a simpler, frontage-based approach. A joint work session was held on February 3, 2026, where both the Planning Commission and City Commission reviewed the draft and supported the direction.

**Planning Commission Action**

The Planning Commission held a public hearing on April 7, 2026, and voted 7-0 to recommend approval of Article XIX as presented.

**Key Elements**

- One (1) tree per 50 feet of street frontage
- Substitutions allowed where utilities or site constraints limit planting
- Credit for existing trees
- Optional incentives for enhanced landscaping
- Cost cap and limited applicability for smaller expansions

**FINANCIAL INFORMATION** N/A

**SUGGESTED MOTION** I move to adopt Ordinance No. 4505 adding a new Article XIX to the Zoning Code related to Landscaping Regulations, as recommended by the Planning Commission.

**SUPPORTING DOCUMENTS**

1. ORDINANCE 4505 - Addition of Article XIX Landscaping to the Zoning Code

**ORDINANCE NO. 4505**

**AN ORDINANCE ADDING A NEW ARTICLE XIX TO THE ZONING CODE OF THE CITY OF INDEPENDENCE, KANSAS, RELATING TO LANDSCAPING REGULATIONS.**

**WHEREAS**, the Planning Commission held a public hearing on April 7, 2026, and recommended approval of Article XIX, Landscaping Regulations; and

**WHEREAS**, the Governing Body finds that the proposed amendment is consistent with the intent of the zoning regulations and is in the best interest of the City.

**NOW THEREFORE, BE IT ORDAINED BY THE GOVERNING BODY OF THE CITY OF INDEPENDENCE, KANSAS:**

**SECTION 1.** There is hereby added to the Zoning Code of the City of Independence, Kansas, a new Article XIX, to read as follows:

**ARTICLE XIX. LANDSCAPING REGULATIONS**

**1900.0 Purpose and Intent**

The purpose of this Article is to establish clear, practical landscaping standards that enhance community appearance, reduce heat from paved surfaces, and encourage the preservation of existing vegetation—while supporting economic development and redevelopment in the City of Independence.

These regulations are designed to be simple, cost-conscious, and achievable within the physical and financial constraints of small-town development.

**1901.0 Applicability**

1901.1 Applicability. The landscaping requirements of this Article shall apply to all new nonresidential and multifamily construction, and to redevelopment or site expansion that increases the total paved or built area of a site by fifty percent (50%) or more.

1901.2 Partial Compliance for Limited Expansions. Projects that expand existing buildings, parking, or paved areas by less than fifty (50%) shall comply only for the newly developed portion of the site.

1901.3 Administrative Flexibility. Where full compliance is impractical due to existing pavement, utilities, or drainage infrastructure, the Zoning Administrator may approve an alternative landscaping arrangement that meets the intent of this Article.

1901.4 Exemptions from Landscaping Requirements. The following uses and situations are exempt from the landscaping requirements of this Article:

- a. Vehicle and equipment sales lots, including new and used automobile, recreational vehicle, boat, and farm implement dealerships.
- b. Single-family and two-family dwellings.
- c. Existing developed properties that are not expanding the footprint of the building or paved area.

1901.5 Encouraged Practices for Exempt Uses. Although exempt from the requirements of this Article, such uses are encouraged to incorporate voluntary beautification features such as:

Foundation plantings or low landscape beds near office or showroom areas;  
Perimeter plantings that do not obstruct product visibility.

## **1902.0 Definitions.**

1902.1 The following terms are defined for this Article:

Public Street Frontage: The portion of a property abutting a public street right-of-way.

Shade Tree: A deciduous tree that typically grows to a mature height of 30 feet or more.

Ornamental Tree: A deciduous tree under 30 feet at maturity, valued for flowers, foliage, or form.

Shrub: A woody perennial plant smaller than a tree, typically over 2 feet tall.

Ornamental or Prairie Grass: A decorative grass species adapted to local soil and climate conditions, often used for low-maintenance landscaping.

Tree Well or Raised Planter: A contained or elevated planting area designed to support tree growth where in-ground planting is restricted.

### **1903.0 Street Frontage Landscaping Requirements.**

1903.1 Tree Requirement. All nonresidential and multifamily developments shall provide at least one (1) shade or ornamental tree per 50 linear feet of public street frontage.

- a. Fractions over 25 feet shall round up to require one additional tree.
- b. Trees may be clustered if a minimum of 20 feet separates each cluster.

1903.2 Placement and Setbacks.

- a. Trees shall be located on private property and outside of the public right-of-way.
- b. Trees shall be located no closer than eight (8) feet to the curb line of adjacent streets or sidewalks.
- c. Trees shall be located at least six (6) feet from underground utilities unless placed in a raised planter or tree well.
- d. Trees shall not be located within drainage easements or public utility easements without City Engineer approval.

1903.3 Substitutions. Where trees cannot be installed due to site constraints or utilities, property owners may substitute five (5) shrubs or ornamental grasses for each required tree.

1903.4 Design Flexibility. Raised planters, tree wells, or foundation beds may satisfy the tree requirement where in-ground planting is not feasible. All planting areas shall be protected by curbing, edging, or raised planters to prevent vehicle damage.

1903.5 Visibility and Safety. Landscaping shall not obstruct visibility at intersections or driveways. All plantings shall meet City sight-distance requirements.

### **1904.0 Existing Tree Preservation Credit.**

Existing healthy trees may be credited toward the required frontage tree count. To qualify, a tree must:

- a. Be in good condition and structurally sound;
- b. Be located within or near the developable portion of the site; and
- c. Have a trunk at least 4 inches across at approximately 4½ feet above ground level.

Trees 8 inches or greater across may count as two (2) required trees. Ornamental trees smaller than 4 inches may count as one-half (½) of a required tree if integrated into site landscaping. Diseased, dead, or hazardous trees shall not be credited.

#### **1905.0 Irrigation and Maintenance.**

- a. Permanent irrigation systems are not required. Temporary watering or manual irrigation during establishment is encouraged.
- b. Landscaping shall be maintained in a healthy, neat, and orderly condition, including mowing, trimming, and replacement of dead or diseased materials.
- c. Seasonal dormancy or browning of native grasses shall not constitute a violation.
- d. All landscaped areas shall be protected from vehicular damage by curbs or barriers.

#### **1906.0 Incentives for Enhanced Landscaping.**

1906.1 Parking Reduction Incentive. Projects providing 50% more trees or landscaping than required, or including landscaped islands within parking areas, may receive up to a 10% reduction in required parking.

Incentives are discretionary and subject to approval by the Zoning Administrator. The Administrator shall ensure the enhancement clearly advances the visual and environmental intent of this Article.

#### **1907.0 Cost Limits and Redevelopment Exemptions.**

- a. Landscaping expenditures shall not be required to exceed three percent (3%) of total verified construction cost for projects involving buildings, or six percent (6%) for projects involving parking lot construction only.
- b. Applicants shall provide contractor or vendor estimates showing total construction cost and landscape costs separately.
- c. The Zoning Administrator may approve substitutions or modifications where full compliance would exceed the cost cap or conflict with utilities, drainage, or easement conditions.

#### **1908.0 Administrative Flexibility.**

- a. The Zoning Administrator may approve alternative landscaping arrangements that meet the intent of this Article when strict compliance is impractical due to site conditions or physical constraints.

- b. Minor changes in plant species, location, or quantity may be approved without re-submittal of a full landscape plan.

**SECTION 2.** If any section, subsection, sentence, clause, or phrase of this Ordinance or the zoning regulations hereby adopted is for any reason held to be invalid or unconstitutional, such decision shall not affect the validity of the remaining portions.

**SECTION 3.** All ordinances or parts of ordinances, in conflict herewith are hereby repealed to the extent of such conflict.

**SECTION 4.** This Ordinance shall take effect and be in force from and after its publication in the official City newspaper.

**ADOPTED BY THE GOVERNING BODY OF THE CITY OF INDEPENDENCE, KANSAS, ON THIS 23RD DAY OF APRIL, 2026.**

---

Dean Hayse, Mayor

**ATTEST:**

---

David Schwenker, City Clerk



# REQUEST FOR COMMISSION ACTION CITY OF INDEPENDENCE

April 23, 2026

Department Police

Director Approval Dustin Stafford

**AGENDA ITEM** Consider closing Locust from Penn to 6th Street, 6th Street from Locust to Chestnut, and Chestnut from 5th to 6th Street for the Independence High School Prom on Saturday, May 2, 2026 from 4:00 PM to approximately 8:30 PM.

**SUMMARY RECOMMENDATION** The City Staff recommends closing the streets for the Independence High School Prom.

**BACKGROUND** Marci Horning, with USD 446, is requesting the following streets be blocked on May 2nd, 2026, from 4:00 PM to approximately 8:30 PM. The blocked streets will allow the Prom participants to drive up and walk into the Civic Center. The following diagram shows the streets that will be blocked during this time.

- Locust from Penn to 6th Street
- 6th Street from Locust to Chestnut
- Chestnut from 6th to 5th Street

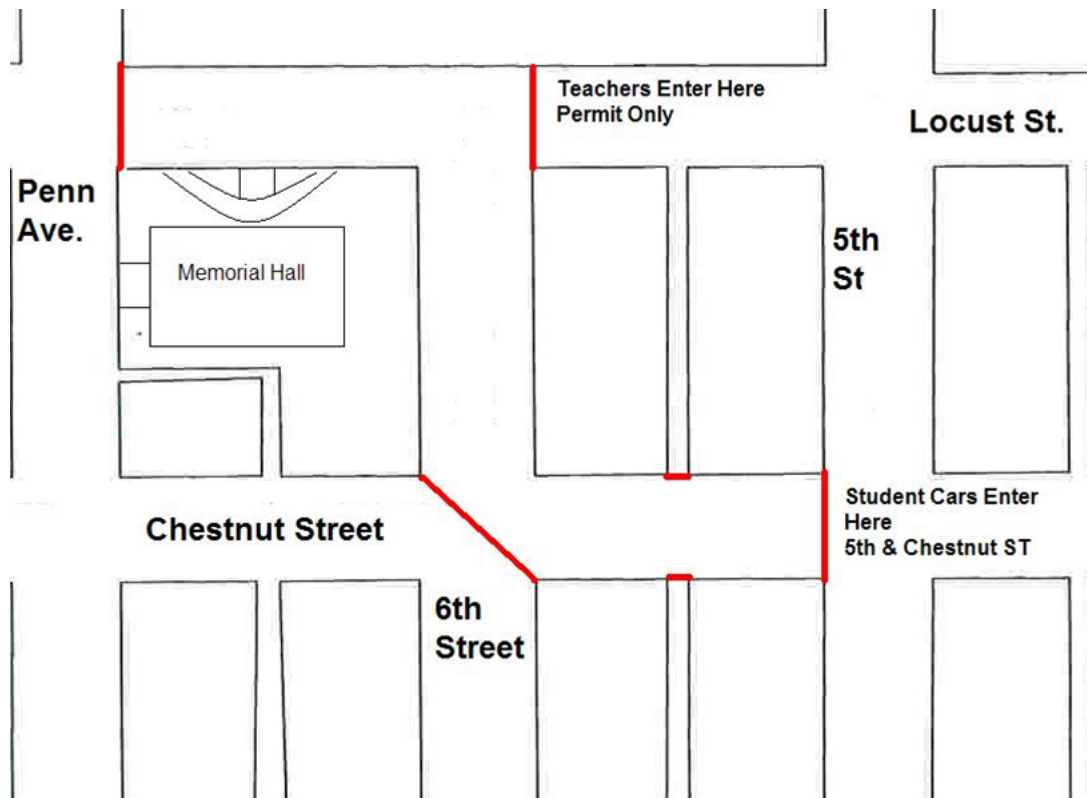

IHS staff will stage the students in their vehicles within the blocked-off area and direct them to the front of the Civic Center where the couples will be announced, and then enter Prom inside the Civic Center. Adult valets will drive the students' cars to the appropriate parking lot while other cars arrive to deposit students. This process takes approximately two hours and begins at 6:00 PM. We have requested 4:00 PM to allow time for barricades to be put in place and vehicles removed from the area if necessary.

**FINANCIAL INFORMATION** N/A

**SUGGESTED MOTION** I move to approve closing Locust from Penn to 6th Street, 6th Street from Locust to Chestnut, and Chestnut from 5th to 6th Street for the Independence High School Prom on Saturday, May 2, 2026 from 4:00 PM to approximately 8:30 PM.

**SUPPORTING DOCUMENTS**



**REQUEST FOR COMMISSION ACTION  
CITY OF INDEPENDENCE**

**April 23, 2026**

**Department Public Works & Utilities**

**Director Approval John Garris**

**AGENDA ITEM** Consider award of the construction of the 2026 Salt-Sand Storage project to A&B Construction, LTD in the amount of \$114,130.00.

**SUMMARY RECOMMENDATION** Authorize award.

**BACKGROUND** The consolidated public works building was purchased in August. In order to bring full functionality to the facility, a location is needed to store road salt and aggregate to provide melting/friction surfaces. The currently existing facility is slated to be sold, and it is recommended to place the new storage facility at the new public works building. The bids were opened on March 19, 2026, and the bid tabulation is attached. The low bidder, was A&B Construction, LTD, in the amount of \$108,150.00. In reviewing the bids, they had not included engineering of the foundation, and provided a price of \$5,980.00 for that review, for a total cost of \$114,130.00.

References reviewed indicated adequate experience in similar work.

**FINANCIAL INFORMATION** This contract will be paid for from the bond funds received for purchasing the new public works facility.

**SUGGESTED MOTION** I move to authorize award of the construction of the 2026 Salt-Sand Storage project to A&B Construction, LTD in the amount of \$114,130.00 and for the execution of any necessary documents.

**SUPPORTING DOCUMENTS**

1. Salt Sand Storage Contract.v.1
2. Salt and Sand Building Bid Tab

## CONTRACT

***This Agreement*** is entered into on the \_\_\_\_\_ day of \_\_\_\_\_, 2026, by and between the **City of Independence, Kansas**, hereafter CITY, and A&B Construction, LTD of Harper, Iowa, hereafter CONTRACTOR.

1. **Project Description:** The project consists of construction of a new salt/sand storage building and associated concrete pad.

2. **Specifications:** The specifications for the work to be performed by CONTRACTOR are as contained in the Independence, Kansas Residuals Invitation to Bid document (attached hereto). Note that a materials, including rebar, are to be provided by CONTRACTOR.

3. **Compensation:** CITY shall pay CONTRACTOR the agreed sum of \$108,150.00 for complete building as specified in the documents plus \$5,980.00 for engineering review to make a total price of \$114,130.00 in the following manner: as a lump sum within 30 days of the completion of the project.

4. **Term of Agreement:** CONTRACTOR shall begin work on the date established by consultation with CITY. The deadline for substantial construction completion shall be October 31, 2026. CONTRACTOR acknowledges that time is of the essence in completion and that CONTRACTOR may be liable for damages due to late completion. Performance and Payment bonds shall be delivered to CITY within 30 days of the signing of this contract.

5. **Change Orders:** Change Orders must be approved in writing, and valid changes are applicable only to work presented to CITY by CONTRACTOR for conditions presented to CITY within 5 business days of the time CONTRACTOR knew or should have known about the change, or upon request by CITY. Damages claimed for delay by

CONTRACTOR may include direct costs only, and cannot include any costs from lost opportunities or any other source.

6. **Indemnification:** CONTRACTOR agrees to indemnify and hold harmless CITY, its agents and employees, for any damages to persons or property arising from acts or omissions of CONTRACTOR, or its agents or employees, in performance of this agreement.

7. **CONTRACTOR Requirements:** CONTRACTOR shall be responsible for, and provide the CITY proof of, the following upon request:

- a. Current Occupational License issued by the City, if required.
- b. A minimum of \$1,000,000.00 general liability insurance.
- c. All statutorily required workers compensation coverage.
- d. A minimum of \$1,000,000.00 in automobile liability insurance.
- e. Performance and payment bonds as specified in the Independence, Kansas Laurel Street Request for Proposal document (previously referenced and attached hereto).

**CITY OF INDEPENDENCE, KANSAS**

\_\_\_\_\_

Date

By: \_\_\_\_\_

\_\_\_\_\_, Mayor

ATTEST:

\_\_\_\_\_

\_\_\_\_\_, City Clerk

\_\_\_\_\_

Date

By: \_\_\_\_\_

NAME:

TITLE:

| <b>Salt and Sand Storage Building</b> | <b>Base Bid</b> | <b>Alternate (Two 20 X 40 Buildings)</b> | <b>Bay Divider Wall</b> | <b>Corrosion Inhibitor in T-Panels</b> |
|---------------------------------------|-----------------|--|-------------------------|--|
| A & B Construction                    | \$ 108,150.00   |  |                         |  |
| Greenfield Contractors                | \$ 145,493.02   |  | \$ 8,608.00             | \$ 9,408.00                            |
| Recrete Design                        | \$ 126,000.00   |  |                         |  |
| PSE Contractors                       | \$ 319,970.00   |  |                         |  |
| Decker Construction                   | \$ 239,900.00   |  |                         |  |
| K W Contractors                       | \$ 167,895.00   | \$ 184,895.00                            |                         |  |



**REQUEST FOR COMMISSION ACTION  
CITY OF INDEPENDENCE**

**April 23, 2026**

**Department Public Works & Utilities**

**Director Approval John Garris**

**AGENDA ITEM** Consider a contract addendum with Green Environmental Recycling and Disposal, LLC for landfill services.

**SUMMARY RECOMMENDATION** Approve contract.

**BACKGROUND** In October of 2025, the City entered into a contract with Green Environmental Recycling and Disposal, LLC (Green). Green indicated that they would be open for business by April 1, 2026. They are not open. The City recently extended the City's contract with Resource Recovery, Inc., our current landfill until September 30, 2026, so the delay in opening of the new facility will not provide a negative impact on our operations. Provisions in the addendum will allow the City to void and rebid the contract with Green should they not show adequate progress.

**FINANCIAL INFORMATION** This will have a net beneficial impact to operational costs for the Sanitation Department due to shorter transport distances and lower fees (Resource Recovery \$47.47 per ton versus Green at \$52.50 per ton).

**SUGGESTED MOTION** I move to approve the contract addendum with Green Environmental Recycling and Disposal, LLC and for the execution of any necessary documents.

**SUPPORTING DOCUMENTS**

1. City Of independence Extension Oct 1. 2026 - Apr 6 2026 - 13-13

## **Addendum to Agreement for Disposal Services**

**This Addendum** is entered into by and between the **City of Independence, Kansas**, a municipal corporation (hereafter CITY) and **Green Environmental Recycling and Disposal, LLC**, a Kansas limited liability company, (hereafter CONTRACTOR).

**Whereas**, the parties entered into an Agreement for Disposal Services on October 22, 2025 to allow CONTRACTOR to dispose of and transport solid waste from the CITY according to the terms of the Agreement and applicable law.

**And Whereas**, the start date for CONTRACTOR'S performance under the Contract was to be April 1, 2026.

**And Whereas**, CONTRACTOR has advised CITY that it will be unable to begin performing services for CITY on April 1, 2026.

**Now Therefore**, in consideration of the mutual covenants and agreements hereinafter contained, the parties agree to the following:

1. **Addendum Controlling.** To the extent that terms and conditions of this Addendum differ from the original Agreement for Disposal Services, the Addendum shall control.

2. **Start Date.** The original start date for performance by CONTRACTOR of its obligations to CITY under the Agreement for Disposal Services was to be April 1, 2026. CONTRACTOR is not able to meet the contemplated start date. As a result, CITY has agreed to modify the timing of the performance of the CONTRACTOR as hereinafter set forth.

3. **Alternative Contractor.** Because CONTRACTOR was unable to meet the April 1, 2026 start date, CITY has contracted with Resource Recovery, Inc for disposal service through September 30, 2026. CONTRACTOR consents to CITY'S use of Resource Recovery, Inc through September 30, 2026.

4. **New Timeline.** On or before May 1, 2026, CONTRACTOR shall provide and demonstrate to CITY, in writing, a clear plan and scope of work for construction of the contemplated transfer station in a timely fashion so that CONTRACTOR may begin performance of its obligations to CITY under the Agreement for Disposal Services on October 1, 2026. If CONTRACTOR is not able to establish a clear plan and scope of work to enable it to perform on that date, CITY may, at its sole option, reopen the bidding process for the providing of solid waste disposal services to CITY on June 1, 2026.

5. **Damages.** If CONTRACTOR is able to provide CITY a clear plan and scope of work for performance on October 1, 2026, then CITY will waive any claim of damages against CONTRACTOR for the delay. In exchange, if CONTRACTOR is not able to provide CITY a clear plan and scope of work for performance on October 1, 2026, City may withdraw from the initial



Agreement for Disposal Services without penalty and CONTRACTOR waives any claim of damages against CITY in that regard.

6. **Binding Effect.** This agreement shall be binding upon the heirs, successors and assigns of the parties hereto.

**City of Independence, Kansas**

---

**Dean Hayse, Mayor**

**ATTEST:**

---

**David Schwenker, City Clerk**

**Green Environmental Recycling  
and Disposal, LLC,**

---

**John F. Hafner, Managing Member**

4/6/26  
DATE



**REQUEST FOR COMMISSION ACTION  
CITY OF INDEPENDENCE**

**April 23, 2026**

**Department Public Works & Utilities**

**Director Approval John Garris**

**AGENDA ITEM** Consider purchasing two replacement salt/sand spreaders from American Equipment Company for \$50,244.00.

**SUMMARY RECOMMENDATION** Authorize purchase.

**BACKGROUND** The Public Works Department utilizes truck-mounted salt/sand spreaders for winter roadway treatment and ice control operations. Existing equipment dates to the 1990s, and has failed. On April 2, 2026, two bids were opened for replacement salt/sand spreaders. The low bid, from American Equipment Company in Kansas City, Kansas, was \$25,122.00 per unit, or \$50,244.00 for two units. The second bidder, Paris Supply of Georgetown, Kentucky was at \$58,157.32 for two units.

Purchase of two units is recommended. There were no bids for trade-in by either bidder, so it is requested that the Commission allow disposal via an auction with Purple Wave, or, if no bids are received, to sell the units as scrap.

**FINANCIAL INFORMATION** The new unit will be paid for from budgeted funds.

**SUGGESTED MOTION** I move to purchase two truck-mounted salt/sand spreaders from American Equipment Company for the amount of \$50,244.00 and to dispose of the existing units as described.

**SUPPORTING DOCUMENTS**

1. American Equipment Co

# American

EQUIPMENT CO.

3250 Harvester Road

Kansas City, Kansas 66115

(Phone) 913-342-1450 (Fax) 913-342-1377

sales@americanequipment.us

## QUOTATION

|           |             |
|-----------|-------------|
| DATE      | Quotation # |
| 3/18/2026 | 031826/15JB |

|                             |
|-----------------------------|
| NAME / ADDRESS              |
| City of Independence Kansas |

|                         |
|-------------------------|
| TO CONFIRM ORDER        |
| Quote Accepted by _____ |
| Date _____              |
| P.O. # _____            |

|                   |       |     |     |       |       |
|-------------------|-------|-----|-----|-------|-------|
| LEAD TIME         | TERMS | REP | FOB | PHONE | Email |
| 60 to 75 days ... | CASH  | JLB |     |       |       |

| QTY | ITEM | DESCRIPTION  | U/M | COST      | Total      |
|-----|------|--|-----|-----------|------------|
| 1   | 300  | <p>Bid for one (1) new municipal-grade truck-mounted salt/sand spreader, with the option to purchase one (1) additional identical unit at the same unit price within ninety (90) days of award, subject to budget availability</p> <p>Salt Dogg Model 14514F692111:</p> <ul style="list-style-type: none"> <li>- 14 foot long x 69" tall</li> <li>- 13.5 cubic yard capacity</li> <li>- Hydraulic power with two independent motors for conveyor and spinner operation</li> <li>- Spreads bulk salt, bulk sand, and 50/50 salt/sand mix.</li> <li>- Hydraulic spreader controls sold separately with variety of options available.</li> <li>- 20 in. poly spinner broadcasts up to 40 ft, using with a height adjustable chute.</li> <li>- Versatile 24 in. wide chain conveyor drive.</li> <li>- Stainless steel, adjustable inverted V reduces stress on the drive line and improves flow.</li> <li>- High quality, 304 stainless steel construction for optimum corrosion resistance.</li> <li>- Heavy duty 3/8 in. hinged top screens with 2-1/2 in. openings.</li> <li>- Includes stainless steel tailgate latch bar kit (NOT installed)</li> </ul> <p>NOT INSTALLED</p> <p>Freight is included to Independence, Kansas</p> <p>***NOTE: NO hydraulics hoses, fittings, quick disconnects, Tie downs, or controls***</p> |     | 25,122.00 | 25,122.00T |
|     |      |  |     |           | 0.00       |

|                       |              |             |
|-----------------------|--------------|-------------|
| Quoted by John Blogin | <b>Total</b> | \$25,122.00 |
|-----------------------|--------------|-------------|

**This quote is valid for 30 days. Applicable taxes not included.**

AMERICAN EQUIPMENT CO. "MARKED SPECS"

## INSTRUCTIONS TO BIDDERS

### 1. INTENT

The City of Independence seeks to purchase one (1) new municipal-grade truck-mounted salt/sand spreader, with the option to purchase one (1) additional identical unit at the same unit price within ninety (90) days of award, subject to budget availability. OK

### 2. BID SUBMISSION

Bids shall be submitted in a sealed envelope clearly marked: OK

"Salt/Sand Spreader Bid"

Each bid shall include:

- Completed Bid Form
- Manufacturer and model information
- Complete specification sheets
- Warranty documentation
- Delivery timeline
- List of exceptions or deviations

OK

Bids received after the stated deadline will not be considered.

### 3. AWARD

Award will be made to the lowest responsive and responsible bidder meeting the specifications and serving the best interest of the City upon approval of the City Commission. OK

# SPECIFICATIONS

## 1. GENERAL REQUIREMENTS

The spreader(s) shall be new, current production municipal-duty units suitable for installation on City-owned trucks and designed for salt, sand, or salt/sand mixture application.

OK

Used or demonstrator equipment must be clearly identified and approved by the City.

N/A (NEW)

## 2. CAPACITY

- Hopper capacity: 13.5 cubic yards OK
- Designed for continuous municipal roadway use OK

## 3. CONSTRUCTION

- 304 stainless steel hopper (preferred) OK
- Reinforced structural frame OK
- Top screens to prevent oversized material entry OK
- Adjustable feed gate OK

## 4. FEED SYSTEM

- 24" wide conveyor chain OK
- Designed to prevent bridging and clogging OK
- Independent control of conveyor and spinner (CONTROLS NOT INCLUDED)  
DUAL HYD MOTORS

## 5. DRIVE & CONTROLS

- Hydraulic drive system OK
- In-cab speed controller NO CONTROLLER
- Weather-resistant wiring harness NO WIRE HARNESS
- Clearly labeled operator controls N/A

## 6. SPREAD PATTERN

- Adjustable spinner OK
- Capable of distributing material up to approximately 30-40 feet OK

## 7. MOUNTING

- Mounting hardware included *TAILGATE CATCH BAR KIT*
- Installation instructions provided *OK*

## 8. WARRANTY

- Minimum one (1) year manufacturer warranty *1 YEAR*
- Warranty documentation provided at delivery

## TRADE-IN OPTION

The City may offer for trade one (2) existing salt/sand spreaders. Information regarding the trade-in units are as follows, and may be inspected upon contacting Aaron Stringer, 620.714.0460: *NO*

- Manufacturer: Unknown
- Model: Stainless body, steel structure and chute, approximately 13 CY *NO*
- Year: 1990s
- Condition: Used / Operational

- Manufacturer: Unknown
- Model: Fiberglass body, steel conveyor, approximately 13 CY *NO*
- Year: Unknown
- Condition: Used / Non-operational

Bidders shall provide:

- Trade-in allowance value (if any) *NONE*
- Description of any inspection required *N/A*
- Statement of acceptance "as-is" condition *N/A*

The City reserves the right to accept or reject any trade-in allowance and may elect to sell surplus equipment separately. *OK*

# DELIVERY

Delivery shall be FOB Destination to:

City of Independence – Public Works  
2143 Enterprise Drive,  
Independence, Kansas

OK

Delivery shall occur within 180 calendar days after receipt of purchase contract, with the City retaining the right to delay delivery for up to that period. *60-75 DAYS*

# TAX EXEMPT STATUS

The City of Independence is exempt from Kansas State Sales Tax. A tax exemption certificate will be provided upon request.

OK

# BID FORM

Bidder Name: AMERICAN EQUIPMENT CO. / JOHN BLOGIN  
Address: 3250 HARVESTER ROAD KC, KS 66115  
Phone: (913) 342-1450  
Email: JOHN@AMERICANEQUIPMENT.US

---

## Base Bid – One (1) Unit

Unit Price: \$ 25,122.00

## Optional Second Unit

Unit Price: \$ 25,122.00

## Trade-In Allowance (If Applicable)

Trade-In Credit: \$ Ø

## Net Price (Base Bid Less Trade-In)

Total: \$ 25,122.00 FOR (1)

Delivery within 60 calendar days.

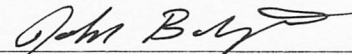
Signature:   
Printed Name: JOHN BLOGIN  
Title: SALES  
Date: 03-18-2026

# Installation and Operator's Manual

## Municipal-Sized Hydraulic Powered Stainless Steel Hopper Spreaders

### Table of Contents

|  |     |
|--|-----|
| General Information.....                             | 1   |
| Average Material Weights .....                       | 1   |
| Safety Precautions .....                             | 1   |
| Safety Symbols .....                                 | 2   |
| General Installation Instructions.....               | 3   |
| Dump Body Mounting.....                              | 3   |
| Chassis Mounting .....                               | 3   |
| Chute Installation .....                             | 3   |
| Hydraulic System Assembly .....                      | 4   |
| Gearbox Oil.....                                     | 4   |
| Spreader Operation.....                              | 4   |
| Initial Priming and Inspecting of the System.....    | 4   |
| Initial Spreader Start Up.....                       | 4   |
| Operating the Spreader.....                          | 4   |
| Spreader Baffle Adjustment .....                     | 5   |
| Spreader Maintenance .....                           | 5   |
| In-Season Maintenance.....                           | 5   |
| End of Season / Off-Season Storage Maintenance ..... | 5   |
| Illustrated Parts List.....                          | 6-8 |

### General Information

Hopper Length: 10' / 120", Overall Length: 143", Width: 82"  
Hopper Length: 12' / 144", Overall Length: 167", Width: 82"  
Hopper Length: 14' / 168", Overall Length: 191", Width: 82"

| HOPPER LENGTH | SIDE HEIGHT | SPREADER EMPTY WEIGHT | LEVEL LOADED CAPACITY | ROUNDED LOAD CAPACITY |
|---------------|-------------|-----------------------|-----------------------|-----------------------|
| FEET          | INCHES      | LBS.                  | CU. YARDS             | CU. YARDS             |
| 10            | 57          | 2,935                 | 7.0                   | 8.0                   |
| 10            | 63          | 3,083                 | 8.3                   | 9.4                   |
| 10            | 69          | 3,175                 | 9.5                   | 10.8                  |
| 12            | 57          | 3,474                 | 8.4                   | 9.8                   |
| 12            | 63          | 3,638                 | 9.9                   | 11.5                  |
| 12            | 69          | 3,742                 | 11.5                  | 13.3                  |
| 14            | 57          | 3,837                 | 9.9                   | 11.5                  |
| 14            | 63          | 4,023                 | 11.6                  | 13.5                  |
| 14            | 69          | 4,135                 | 13.4                  | 15.5                  |

*Weights shown above are references only and will vary based on configuration and conditions*

### CAUTION

Consult federal, state and local weight laws and chassis manufacturer's ratings to ensure that government weight restrictions, GVWR and GAWRs are not exceeded.

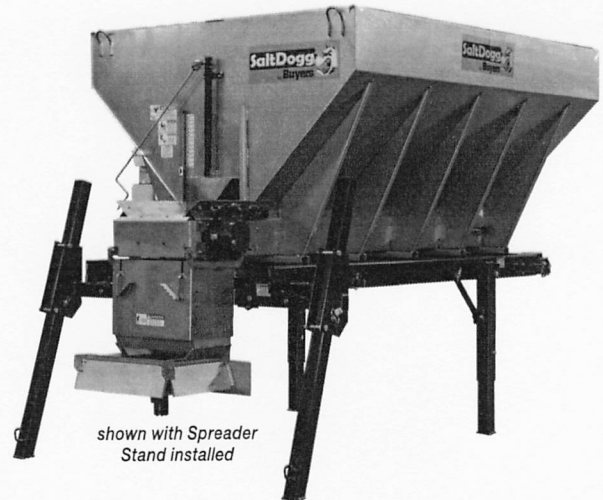

shown with Spreader Stand installed

### Average Material Weights

MATERIAL WEIGHT (POUNDS PER CUBIC YARD)

- Rock Salt – 2,160 lbs per cubic yard
- Sand weight, course dry – 2,565 lbs per cubic yard
- Sand weight, course wet – 3,240 lbs per cubic yard

*Note: To calculate the total Gross Spreader Weight (including ice control material), add the empty spreader weight plus the ice control material and spreader accessories.*

### Safety Precautions



This symbol points out important safety instructions which, if not followed, could endanger the personal safety and/or property of yourself and others. Read and follow all instructions in this manual before attempting to install or operate this spreader. Failure to comply with these instructions may result in personal injury. When you see this symbol. HEED ITS WARNING!

### SPREADER WARRANTY INFORMATION

This warranty replaces all previous warranties and no employee of this company is authorized to extend additional warranties, or agreements, or implications not explicitly covered herein.

Buyers Products Company warrants all parts of the product to be free from defects in material and workmanship for a period of one (1) year. Parts must be properly installed and used under normal conditions. Normal wear is excluded.

Any part which has been altered, including modifications, misuse, accident, or lack of maintenance will not be considered under this warranty.

The sole responsibility of Buyers Products Company under this warranty is limited to repairing or replacing any part(s) which are returned, prepaid, 30 days after such defect is discovered, and returned part(s) are found to be defective by Buyers Products Company.

Authorization from Buyers Products Company must be obtained before returning any part. The following information must accompany defective parts returned to Buyers Products Company: RMA#, spreader model, serial number, date installed, and distributor from whom purchased.

Buyers Products Company shall not be liable for damage arising out of failure of any unit to operate properly, or failure, or delay in work, or for any consequential damages. No charges for transportation or labor performed on any part will be allowed under this warranty.

**⚠ DANGER**

This spreader was built to be operated according to the safe operation practices in this manual. As with any type of power equipment, carelessness or error on the part of the operator can result in serious injury. This spreader is capable of amputating hands and feet and throwing objects. Failure to observe the following safety instructions may result in serious injury or death.

**⚠ WARNING**

Improper installation and operation could cause personal injury, and/or property damage. Observe the following Safety Precautions before, during and after operating this spreader. By following these precautions and common sense, possible injury to persons and potential damage to this spreader may be avoided.

- Read and fully understand the entire Installation and Operator's Manual before operating this spreader.
- Read and fully understand all safety decals on the spreader before operating the spreader.
- Check to make sure all safety guards and shields are securely mounted and in place before operating this spreader. Never remove or modify guards or shields.
- Verify that all personnel are clear of the spreader spray area before starting or operating this spreader.
- Do not over-load your vehicle beyond payload limits. If there are any questions, contact the end stage vehicle manufacturer.
- Shut off vehicle before servicing, adjusting, or cleaning. Do not unclog material jams without shutting off the vehicle and disconnecting the hydraulics.
- Do not climb, sit, walk or ride on the conveyor at any time. Do not ride on the spreader while the vehicle is in motion.
- Keep hands, feet, hair and loose clothing away from moving parts.
- Make sure the spreader is securely fastened to the vehicle in accordance with this Installation and Operator's Manual.
- Do not operate a spreader that needs maintenance or repairs.
- Do not operate the spreader while ill, tired, or under the influence of alcohol or drugs.

**⚠ WARNING**

It is recommended to install Backup Alarm on trucks to be up fitted with spreaders.

**Safety Symbols**

The following pages show safety symbols that may appear on this product. Read and fully understand all safety decals on the spreader before operating the spreader.

**⚠ DANGER / PELIGRO**



- Read and fully understand Operator's Manual before using this spreader.
- Failure to follow installation and operating instructions may result in serious injury or death!
- Do not climb, sit, walk or ride on conveyor/auger at any time.
- Exposed conveyor/auger and moving parts may cause serious injury or death.
- Disconnect and lock out power before servicing, adjusting or cleaning.
- Keep hands, feet, hair and loose clothing away from moving parts.
- Never remove or modify guards or shields.
- Use care when the spreader is being mounted, dismounted, or stored.

• Lea y entienda completamente el Manual del Operador antes de usar este esparcidor.  
 • ¡Si no se siguen las instrucciones de instalación y funcionamiento se pueden producir lesiones graves o la muerte!  
 • No suba, se siente, camine o monte en el transportador/sinfin en ningún momento.  
 • La exposición del transportador/sinfin y de las piezas móviles puede producir lesiones graves o la muerte.  
 • Desconecte y bloquee la energía antes de realizar el mantenimiento, el ajuste o la limpieza.  
 • Aleje las manos, los pies, el cabello y la ropa holgada de las piezas móviles.  
 • Nunca quite o modifique los protectores o blindajes.  
 • Tenga cuidado al montar, desmontar o almacenar el esparcidor.

**⚠ WARNING / ADVERTENCIA**

|   |  |
|---|--|
| <p>DO NOT EXCEED VEHICLE PAYLOAD RATING</p> <ul style="list-style-type: none"> <li>• SALT WEIGHT: 2,160 LBS PER CUBIC YARD</li> <li>• SAND WEIGHT: COURSE DRY 2,565 LBS PER CUBIC YARD</li> <li>• SAND WEIGHT: COURSE WET 3,240 LBS PER CUBIC YARD</li> </ul> | <p>NO EXCEDA LA CAPACIDAD DE CARGA DEL VEHICULO</p> <ul style="list-style-type: none"> <li>• PESO DE LA SAL: 2160 LIBRAS POR YARDA CÚBICA</li> <li>• PESO DE LA ARENA: GRUESA SECA 2565 LIBRAS POR YARDA CÚBICA</li> <li>• PESO DE LA ARENA: GRUESA MOJADA 3240 LIBRAS POR YARDA CÚBICA</li> </ul> |
|---|--|

Located On The Rear Of The Spreader

**⚠ DANGER / PELIGRO**



- Read and fully understand Operator's Manual before using this spreader.
- Failure to follow installation and operating instructions may result in serious injury or death!
- Do not climb, sit, walk or ride on conveyor/auger at any time.
- Exposed conveyor/auger and moving parts may cause serious injury or death.
- Disconnect and lock out power before servicing, adjusting or cleaning.
- Keep hands, feet, hair and loose clothing away from moving parts.
- Never remove or modify guards or shields.
- Use care when the spreader is being mounted, dismounted, or stored.

• Lea y entienda completamente el Manual del Operador antes de usar este esparcidor.  
 • ¡Si no se siguen las instrucciones de instalación y funcionamiento se pueden producir lesiones graves o la muerte!  
 • No suba, se siente, camine o monte en el transportador/sinfin en ningún momento.  
 • La exposición del transportador/sinfin y de las piezas móviles puede producir lesiones graves o la muerte.  
 • Desconecte y bloquee la energía antes de realizar el mantenimiento, el ajuste o la limpieza.  
 • Aleje las manos, los pies, el cabello y la ropa holgada de las piezas móviles.  
 • Nunca quite o modifique los protectores o blindajes.  
 • Tenga cuidado al montar, desmontar o almacenar el esparcidor.

Located On Each Side Of The Spreader

**⚠ DANGER / PELIGRO**

**STAY CLEAR OF TURNING SPINNER**

**MANTÉNGASE LEJOS DEL GIRANDO HILANDERO**

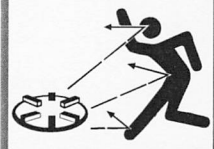

Located on the Rear Chute Assembly / Spinner

**⚠ WARNING / ADVERTENCIA**



- Make certain area behind spreader is clear before releasing the chute.
- Pinch Point: Keep hands clear when un-latching and latching the rear spinner.
- Failure to maintain clearance while releasing the chute may result in serious injury or death!

• Asegúrese de que el área detrás del esparcidor está despejada antes de liberar la tolva.  
 • Punto de pellizco: Mantenga las manos alejadas cuando desengancha y engancha el girador trasero.  
 • Si no se mantiene el espacio libre mientras se libera la tolva, se pueden producir lesiones graves o la muerte.

Located On The Lower Long Sill On Both Sides Near The Chute Release Pin

## General Installation Instructions

This model of spreader is intended to be installed on a standard 34" wide truck chassis or inside an appropriate length (approximately 84" long) dump body. Use the following as a guide for installation.

### Dump Body Mounting

1. Remove the tailgate from the vehicle if applicable.
2. Lift the spreader using the (4) lifting loops in the corners of the hopper.

#### WARNING

The lifting device must be adequately rated to lift a payload equal to or greater than the spreader weight. See page 1 for spreader weights. Empty the spreader before lifting.

3. Center the spreader in the vehicle. The spreader sills must overhang 20" beyond the back end of the vehicle.
4. If the dump body is not flat, place the spreader on two 1" x 6" hardwood boards. This will evenly distribute the weight of the loaded spreader on the entire cross channels.
5. The spreader may be secured to the vehicle by using the Chain Tie Down Kit for SaltDogg® Municipal Hopper Spreaders, Buyers Products part number 3010548 (sold separately) and rear latch bar kit Buyers Products part number 3008560 (steel) or 3036588 (stainless) (sold separately).

#### CAUTION

Inspect tie downs and hardware after each time spreader is loaded. Tighten tie downs and hardware if necessary.

### Chassis Mounting

1. Hardwood wear strips usually 1" x 3" (not furnished) must be fitted to the truck chassis.
2. Lift the spreader using the (4) lifting loops in the corners of the hopper.

#### WARNING

The lifting device must be adequately rated to lift a payload equal to or greater than the spreader weight. See page 1 for spreader weights. Empty the spreader before lifting.

3. The spreader must be positioned on the wooden wear strips so the hopper sills overhang 20" beyond the back end of the vehicle.
4. In addition, approximately 4"-6" must be left between the truck cab and the front of the hopper. This will help facilitate any future servicing of the conveyor chain.
5. A qualified installer must fabricate suitable angles to attach the spreader's hopper cross members to truck's frame.

#### CAUTION

DO NOT weld mounting angles to the truck frame. Doing so can cause fatigue cracking of the truck frame.

### Chute Installation

1. Bolt chute to Rear Chute Guide using screws, washers and nuts. Place washers between Chute Guide tabs and Chute brackets.
2. Make certain the Latch Pin is in the un-locked/retracted position on both sides of the spreader

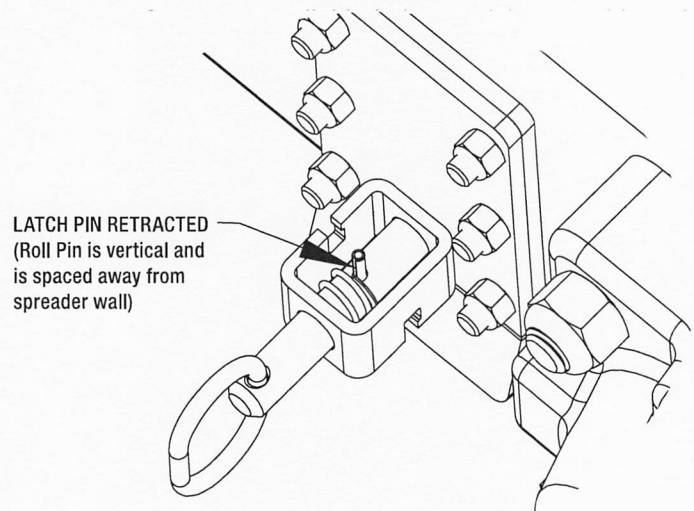

3. Rotate the chute towards vehicle. The Latch Pins will engage the Chute locking the chute in the up position. Be certain both Patch Pins have locked / are fully engaged into the Chute.
4. Chute heights can be adjusted vertically by sliding lower chute assembly up or down inside the upper chute assembly. Adjustment slots are spaced by 3". Before making this adjustment, support the lower chute to support the assembly. Once the chute is in the desired vertical position, secure lower chute assembly using four (4) carriage bolts provided. Make sure all four bolts are used for installation.

## Hydraulic System Assembly

1. During assembly, take precautions to keep all hydraulic components as clean as possible. See the figure below for hydraulic schematic
2. Allow enough hose length to prevent kinking and stretching of the hoses. Support long hose runs with cable ties or clamps.
3. Protect hoses from wear caused by sliding and/or vibration.
4. For proper rotation of conveyor chain and spinner motors, hoses may be reversed. *Note: Use of a pipe joint sealant compatible with hydraulic oil is recommended for all pipe thread fittings.*

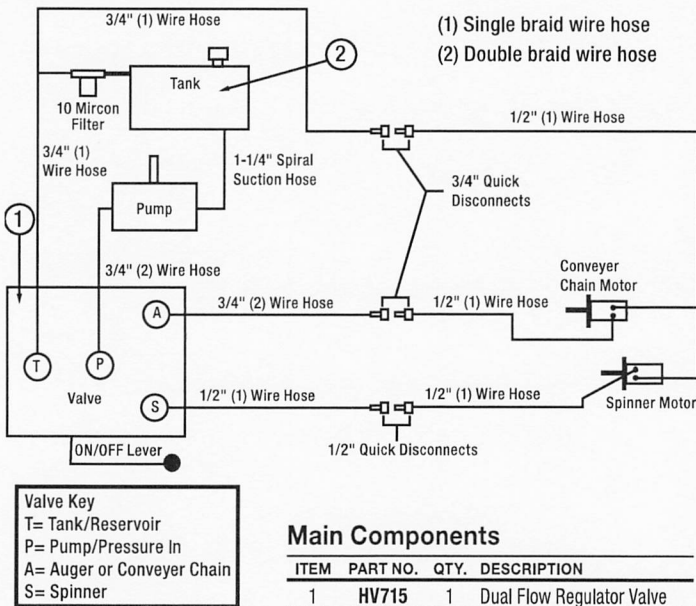

## Gearbox Oil

The gearbox of this spreader is filled with ISO VG460 synthetic oil at the factory. This oil has operating temperature -40° C to 150°C. Verify that this oil meets your operating temperature requirements. If not, empty and refill with the proper viscosity oil.

### IMPORTANT

Before starting spreader, always check that the gearbox is filled to the proper level with oil.

## Spreader Operation

### WARNING

- Before working in or around spreader equipment, be sure all hydraulic controls are moved to OFF position, the PTO must be disengaged (OFF) and the truck engine must be shut off.
- When operating, be sure everyone is standing clear of spreader.
- Be alert for anything that may require shutting down the system.
- Equipment must be started up slowly and watched from a safe distance.

## Initial Priming and Inspecting of the System

1. Make certain the spreader hopper is empty
2. Fill oil reservoir approximately 3/4 full using high grade non-foaming hydraulic oil
3. Be certain the manual spreader valve ON/OFF lever is in the OFF position
4. Start the truck engine
5. Engage PTO and circulate hydraulic oil for several minutes to warm up hydraulic system
6. Position manual spreader valve ON/OFF lever to ON position
7. Rotate the conveyor chain control knob and spinner control knob on the manual spreader valve to the desired operating position
8. Check the conveyor chain and spinner to see that they are working properly and rotating in the correct direction
  - a. To reverse rotation, switch the hydraulic lines at the motor. Only service your spreader when the truck engine is OFF
9. Shut the truck engine OFF
10. Inspect hydraulic system for leaks
11. Refill oil reservoir to 3/4 full
12. Hydraulic system is now be ready for use

## Initial Spreader Start Up

1. Set feed gate opening and baffle positions for desired material flow and spread pattern. See Spreader Baffle Adjustment section on page 5.
2. Check to make certain that no loose parts or other material are in hopper, chute or on the spinner disk
3. Warm up the hydraulic system
  - a. Start the truck engine
  - b. Engage PTO and circulate hydraulic oil for several minutes
  - c. Position manual spreader valve ON/OFF lever to ON position
  - d. Rotate the conveyor chain control knob and spinner control knob on the manual spreader valve to the desired operating position
  - e. Move the ON/OFF lever to the OFF position after warming up the system. Position the spinner and conveyor chain control knobs to the desired settings
4. Put spreading material in the V-Box.
5. Changing the conveyor chain and spinner speeds as well as adjusting the feed gate and baffle positions will produce various spread patterns. See Spreader Baffle Adjustment section on pg 5.

## Operating the Spreader

1. Adjust the internal and external spinner baffles to positions that you have previously determined to give you desired spread pattern. See Spreader Baffle Adjustment section below.
2. Before each use, warm up the hydraulic system following the procedure described in the Initial Spreader Setup section
3. Valve setting changes may be made with truck in motion
4. Allow Manual Spreader Valve to cool down before moving ON/OFF lever to the OFF position.
  - a. Moving the Manual Spreader Valve to the OFF position will stop the spinner and conveyor at the same time without changing their knob/valve settings.

### CAUTION

Always follow the following precautions so as not to cause damage to the spreader.

- If the conveyor chain does not move because of dense material or a material jam, with the truck off, remove all material from the hopper and free the chain.
- To prevent the feed chain from freezing, do not store material in the spreader.
- If the material in the hopper freezes, move the spreader into a warm area to thaw.
- The gearbox is designed to only accept torque from the input shaft. Therefore, **DO NOT ATTEMPT TO FREE THE CONVEYOR BY USING A PIPE OR SIMILAR TOOL TO MOVE OR DISLodge THE CHAIN.** This action will void all warranties.

## Spreader Baffle Adjustment

The spread pattern and the amount of material dispensed will depend on the following factors:

- Vehicle speed
- Conveyor speed
- Spinner RPM
- Feed gate door position
- Baffle setting

Below are illustrations that show the baffles effect on the spread pattern as viewed from the top of the spinner disk.

### Internal Baffle Adjustment

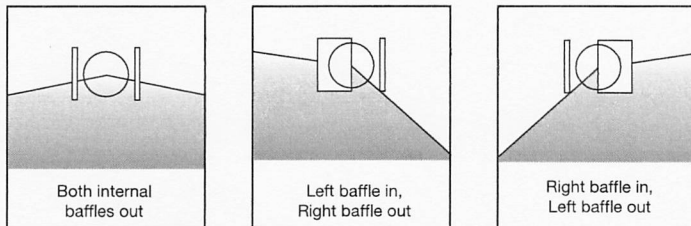

### External Baffle Adjustment

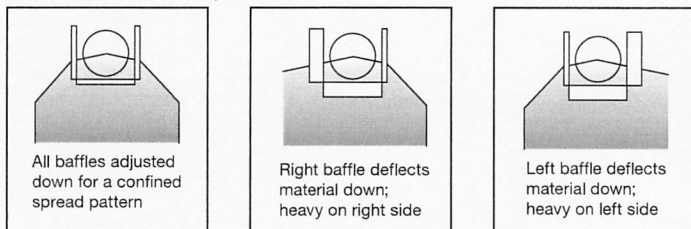

## Spreader Maintenance

### In-Season Maintenance

1. Wash spreader after every use. Make sure no material is left under auger/ chain and/or inside trough.
2. Inspect and retighten fasteners after every 7-10 hours of operation. Replace any loose or damaged fasteners.
3. Lubricate your spreader every 7-10 hours of operation and/or following every snow event using a lithium NLGI #2 rated general purpose marine grade grease.
  - a. Idler Shaft Bearings (2)
  - b. Drive Shaft Bearing (1)
  - c. Feed Gate Jack
  - d. Gearbox Input Shaft (if equipped with a fitting)
  - e. Check the gearbox oil level and maintain the proper  $\frac{3}{4}$  full level by adding the appropriate lubricant. Use care to keep contaminants from getting in reservoir when checking and filling.
4. Check the Feed Chain tension periodically. See the Chain Tension Diagram below. When adjusting the chain, be certain to adjust both sides equally. This adjustment is made on each side of the spreader at the Idler Bearing.
5. Lubricate the conveyor chain at least once per week. Use Lucas Oil® 10014 chain lubricant or similar all-weather lubricant.
6. If applicable, use dielectric grease on all electrical connectors before an electrical connection is made or after connector is disconnected
7. It is recommended to cover spreader with the tarp during storage periods.

### Chain Tension Diagram

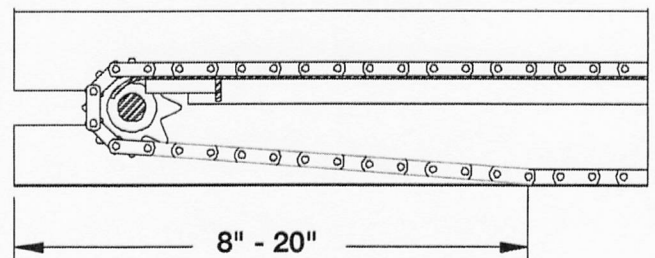

### End of Season / Off-Season Storage Maintenance

1. Wash spreader. Make certain no material or residue is left in or outside the hopper. Thoroughly dry all metal surfaces. Re-paint and oil all previously painted surfaces and chains to protect from rust.
2. Lubricate all bearings (see list above) using lithium NLGI #2 rated general purpose marine grade grease
3. If applicable, inspect wire near connections checking for broken or missing insulation or corroded wires. Trim corroded wires and replace connectors if necessary. Apply dielectric grease on all electrical connections.
4. Store hopper indoors, in a cool, dry place.
5. If applicable, remove controller from truck. Store controller indoors, in a cool, dry place.

# Hopper Assembly

## Hyd. Motor 25:1 Ratio and 50:1 Ratio

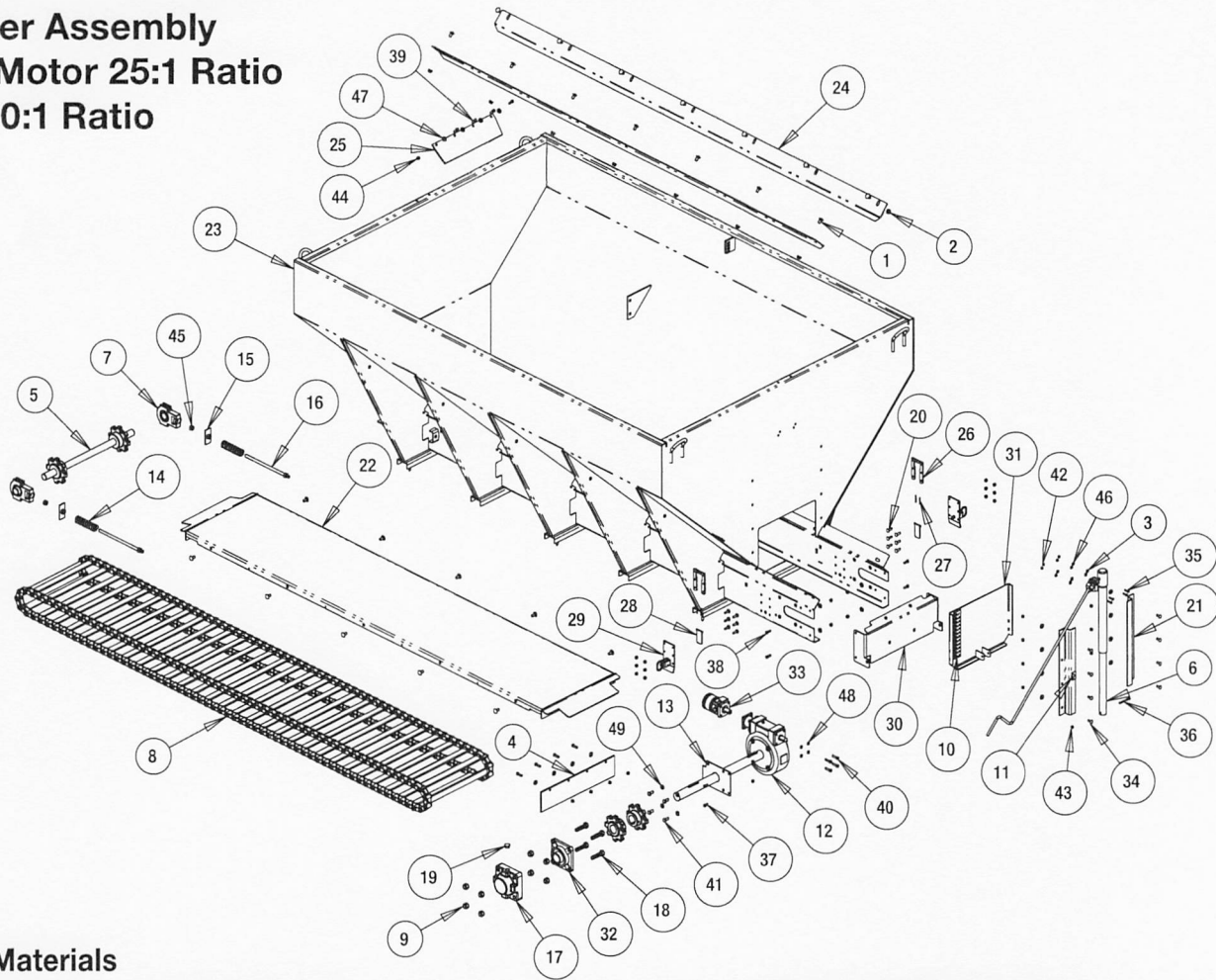

### Bill of Materials

| ITEM | PART NO. | QTY. | DESCRIPTION                              |
|------|----------|------|--|
| 1    | 3001522  | 24   | BOLT, CARRIAGE 1/2-13 X 1 SST            |
| 2    | 3001523  | 24   | NUT, HX FLNG 1/2-13 SST                  |
| 3    | 3002711  | 4    | WASHER, 1/4 FLAT NYLON                   |
| 4    | 3010131  | 1    | WIPER, RUBBER                            |
| 5    | 3010358  | 1    | IDLER SHAFT, ASSEMBLY                    |
| 6    | 3010443  | 1    | JACK ASSEMBLY, FEED GATE                 |
| 7    | 3010603  | 2    | BEARING, HD TAKE-UP 1.5 DIA.             |
| 8    | 3010653  | 1    | CHAIN, 10 FT. D667X CONVEYOR             |
|      | 3015545  | 1    | CHAIN, 12 FT. CONVEYOR                   |
|      | 3015134  | 1    | CHAIN, 14 FT. CONVEYOR                   |
| 9    | 3010659  | 8    | NUT, HEX NYLOCK 3/4-10 SST               |
| 10   | 3010917  | 1    | DECAL, GAUGE FEED GATE                   |
| 11   | 3010918  | 1    | DECAL, POINTER FEED GATE                 |
| 12   | 3010991  | 1    | GEAR BOX 25:1, SPROCKETS ASSEMBLY        |
|      | 3010847  | 1    | GEAR BOX 50:1, SPROCKETS ASSEMBLY        |
| 13   | 3019694  | 1    | ADAPTER GEAR BOX                         |
| 14   | 3023022  | 2    | SPRING CHAIN TENSION                     |
| 15   | 3023044  | 2    | TAKE-UP NUT WELDMENT                     |
| 16   | 3023046  | 2    | BOLT, WELDED TAKE UP                     |
| 17   | 3025824  | 1    | COVER, BEARING 4F32SCR                   |
| 18   | 3026276  | 4    | SCREW HH, 3/4-10 X 3.0 FULL THREAD, SST  |
| 19   | 3026277  | 1    | PLUG, BEARING COVER                      |
| 20   | 3031483  | 12   | BOLT, 3/8-16 X 1 CARRIAGE SHORT NECK SST |
| 21   | 3046017  | 2    | GUIDE, FEED GATE                         |
|      | 3046028  | 1    | FLOOR WELDMENT, 10 FT                    |
| 22   | 3047444  | 1    | FLOOR WELDMENT, 12 FT                    |
|      | 3047579  | 1    | FLOOR WELDMENT, 14 FT                    |
|      | 3046031  | 1    | HOPPER WELDM 10FT 57IN                   |
| 23   | 3047432  | 1    | HOPPER WELDM 12FT 57IN                   |
|      | 3047575  | 1    | HOPPER WELDM 14FT 57IN                   |

| ITEM | PART NO.       | QTY. | DESCRIPTION                               |
|------|----------------|------|---|
| 24   | 3046034        | 2    | CHAIN SHIELD, 10FT                        |
|      | 3047443        | 2    | CHAIN SHIELD, 12FT                        |
|      | 3047581        | 2    | CHAIN SHIELD, 14FT                        |
| 25   | 3046039        | 1    | WIPER, RUBBER                             |
| 26   | 3046371        | 2    | SPACER, CHUTE ATTACHMENT                  |
| 27   | 3046372        | 4    | SPRING, CHUTE ATTACHMENT                  |
| 28   | 3046374        | 2    | PLUNGER                                   |
| 29   | 3046375        | 2    | COVER WELDMENT                            |
| 30   | 3046376        | 1    | GUIDE, CHUTE                              |
| 31   | 3046811        | 1    | FEED GATE, WELDMENT                       |
| 32   | 4F32SCR        | 1    | BEARING FLANGE 2.0 DIA, 4 HOLES SET SCREW |
| 33   | CM034P         | 1    | MOTOR, HYD 4 BOLT 7.3 CI/R                |
| 34   | FCB037516100SS | 8    | BOLT, 3/8-16 X 1 CARRIAGE SST             |
| 35   | FCS025020100SS | 4    | SCREW, CAP HEX HD 1/4-20 X 1 SST          |
| 36   | FCS031018300SS | 1    | SCREW, HH CAP 5/16-18 X 3 SST             |
| 37   | FCS038016075SS | 3    | SCREW, HHC-3/8-16 X 3/4 SST               |
| 38   | FCS038016100SS | 4    | SCREW, HHC 3/8-16 X 1 304 SST             |
| 39   | FCS038016125SS | 8    | SCREW, HHC-3/8-16 X 1.25 SST              |
| 40   | FCS038016150SS | 4    | SCREW, HX HD CAP 3/8-16 X 1-1/2 SST       |
| 41   | FCS050013100SS | 4    | SCREW, HHC-1/2-13 X 1 SST                 |
| 42   | FNE025020031SS | 4    | NUT, NYLON INSERT 1/4-20 SST              |
| 43   | FNE031018034SS | 1    | NUT, NYLOCK 5/16-18 SS                    |
| 44   | FNE038016044SS | 35   | NUT, NYLOCK 3/8-16 X 7/16 SST             |
| 45   | FNH063011054SS | 2    | NUT, HH 5/8-11 X 17/32 HIGH SST           |
| 46   | FWF025063007SS | 4    | WASHER, FLAT 1/4 SAE SS                   |
| 47   | FWF038100007SS | 20   | WASHER, FLAT 3/8 USS SST                  |
| 48   | FWL038069009SS | 4    | WASHER, LOCK RHS-3/8 SST                  |
| 49   | FWL050088013SS | 4    | WASHER, LOCK - 1/2 SPLIT SST              |

# Hopper Assembly Hyd. Motor 6:1 Ratio

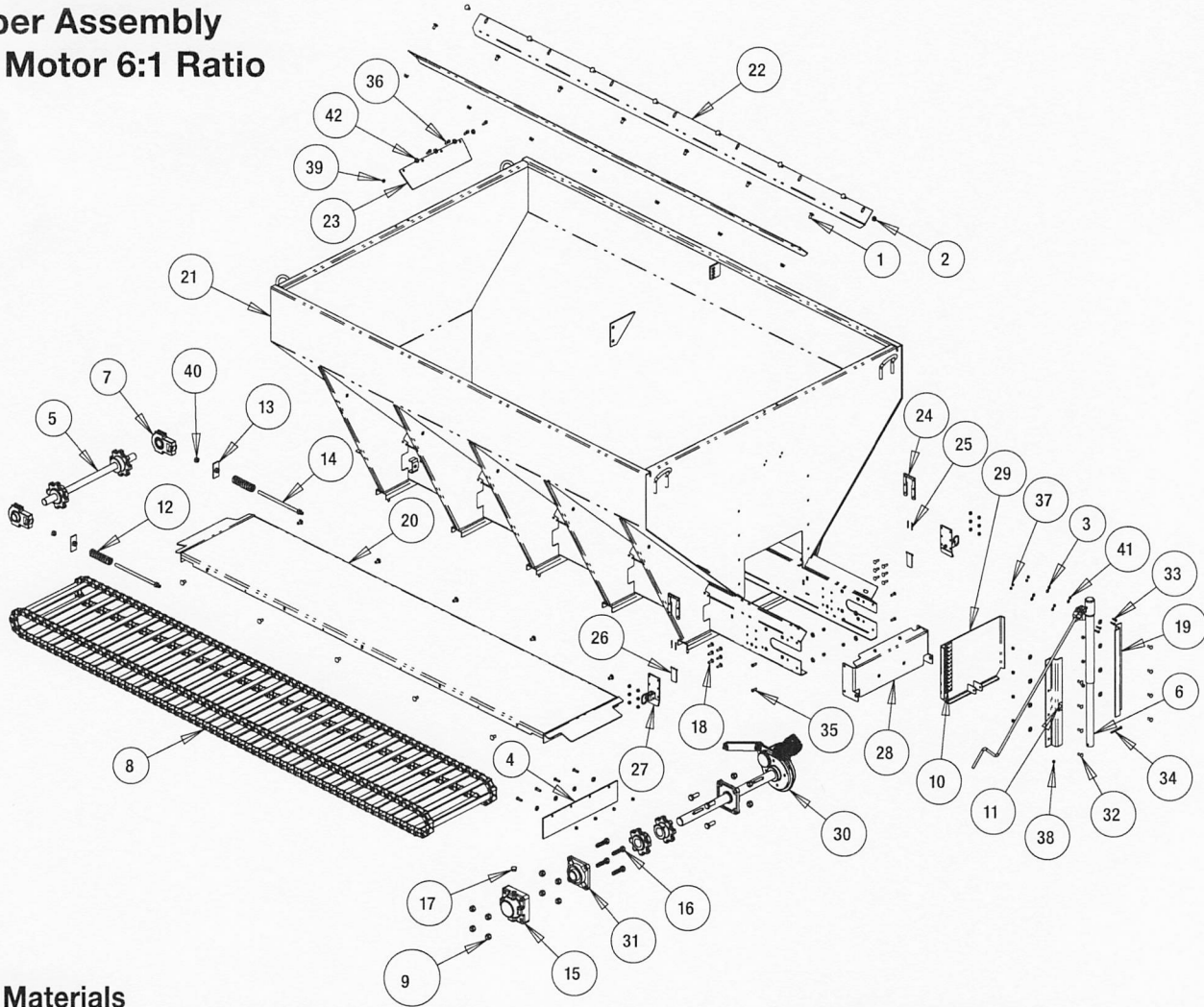

## Bill of Materials

| ITEM | PART NO. | QTY. | DESCRIPTION                              |
|------|----------|------|--|
| 1    | 3001522  | 24   | BOLT, CARRIAGE 1/2-13 X 1 SST            |
| 2    | 3001523  | 24   | NUT, HX FLNG-1/2-13 SST                  |
| 3    | 3002711  | 4    | WASHER, 1/4 FLAT NYLON                   |
| 4    | 3010131  | 1    | WIPER, RUBBER                            |
| 5    | 3010358  | 1    | IDLER SHAFT, ASSEMBLY                    |
| 6    | 3010443  | 1    | JACK ASSEMBLY, FEED GATE                 |
| 7    | 3010603  | 2    | BEARING, HD TAKE-UP 1.5 DIA.             |
| 8    | 3010653  | 1    | CHAIN, 10 FT. D667X CONVEYOR             |
|      | 3015545  | 1    | CHAIN, 12 FT. CONVEYOR                   |
|      | 3015134  | 1    | CHAIN, 14 FT. CONVEYOR                   |
| 9    | 3010659  | 8    | NUT, HEX NYLOCK 3/4-10 SST               |
| 10   | 3010917  | 1    | DECAL, GAUGE FEED GATE                   |
| 11   | 3010918  | 1    | DECAL, POINTER FEED GATE                 |
| 12   | 3023022  | 2    | SPRING CHAIN TENSION                     |
| 13   | 3023044  | 2    | TAKE-UP NUT WELDMENT                     |
| 14   | 3023046  | 2    | BOLT, WELDED TAKE UP                     |
| 15   | 3025824  | 1    | COVER, BEARING 4F32SCR                   |
| 16   | 3026276  | 4    | SCREW HH, 3/4-10X3.0 FULL THREAD, SST    |
| 17   | 3026277  | 1    | PLUG, BEARING COVER                      |
| 18   | 3031483  | 12   | BOLT, 3/8-16 X 1 CARRIAGE SHORT NECK SST |
| 19   | 3046017  | 2    | GUIDE, FEED GATE                         |
|      | 3046028  | 1    | FLOOR WELDMENT, 10 FT                    |
|      | 3047444  | 1    | FLOOR WELDMENT, 12 FT                    |
| 20   | 3047579  | 1    | FLOOR WELDMENT, 14 FT                    |
|      | 3046031  | 1    | HOPPER WELDM 10FT 57IN                   |
|      | 3047432  | 1    | HOPPER WELDM 12FT 57IN                   |
| 21   | 3047575  | 1    | HOPPER WELDM 14FT 57IN                   |

| ITEM | PART NO.       | QTY. | DESCRIPTION                               |
|------|----------------|------|---|
| 22   | 3046034        | 2    | CHAIN SHIELD, 10FT                        |
|      | 3047443        | 2    | CHAIN SHIELD, 12FT                        |
|      | 3047581        | 2    | CHAIN SHIELD, 14FT                        |
| 23   | 3046039        | 1    | WIPER, RUBBER                             |
| 24   | 3046371        | 2    | SPACER, CHUTE ATTACHMENT                  |
| 25   | 3046372        | 4    | SPRING, CHUTE ATTACHMENT                  |
| 26   | 3046374        | 2    | PLUNGER                                   |
| 27   | 3046375        | 2    | COVER WELDMENT                            |
| 28   | 3046376        | 1    | GUIDE, CHUTE                              |
| 29   | 3046811        | 1    | FEED GATE, WELDMENT                       |
| 30   | 3047216        | 1    | GEAR BOX 6:1 ASM.                         |
| 31   | 4F32SCR        | 1    | BEARING FLANGE 2.0 DIA, 4 HOLES SET SCREW |
| 32   | FCB037516100SS | 8    | BOLT, 3/8-16 X 1 CARRIAGE SST             |
| 33   | FCS025020100SS | 4    | SCREW, CAP HEX HD 1/4-20 X 1 SST          |
| 34   | FCS031018300SS | 1    | SCREW, HH CAP 5/16-18 X 3 SST             |
| 35   | FCS038016100SS | 4    | SCREW, HHC 3/8-16 X 1 304 SST             |
| 36   | FCS038016125SS | 8    | SCREW, HHC-3/8-16 X 1.25 SST              |
| 37   | FNE025020031SS | 4    | NUT, NYLON INSERT 1/4-20 SST              |
| 38   | FNE031018034SS | 1    | NUT, NYLOCK 5/16-18 SS                    |
| 39   | FNE038016044SS | 35   | NUT, NYLOCK 3/8-16 X 7/16 SST             |
| 40   | FNH063011054SS | 2    | NUT, HH 5/8-11 X 17/32 HIGH SST           |
| 41   | FWF025063007SS | 4    | WASHER, FLAT 1/4 SAE SS                   |
| 42   | FWF038100007SS | 20   | WASHER, FLAT 3/8 USS SST                  |

## Chute Assembly

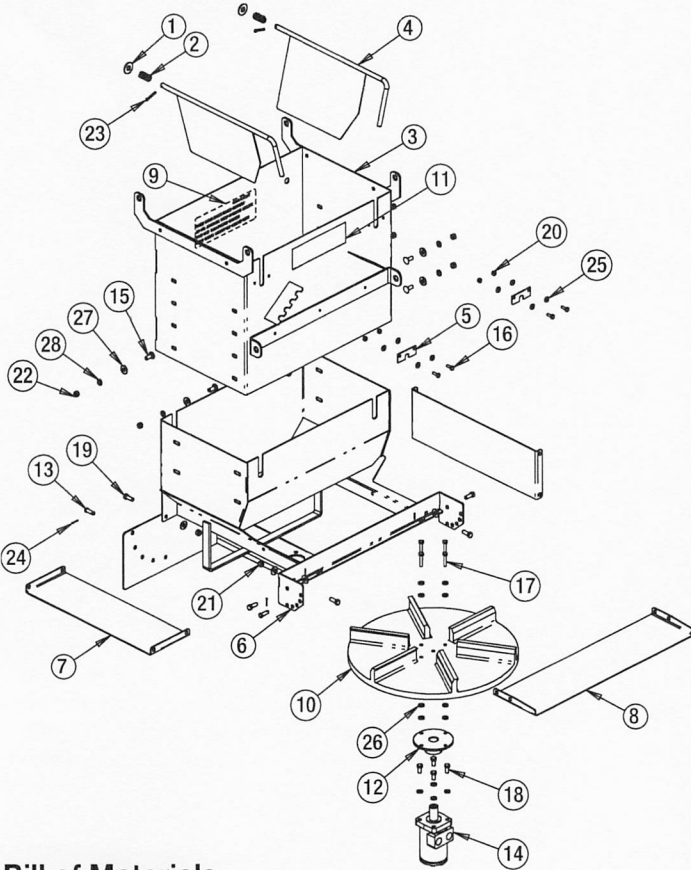

### Bill of Materials

| ITEM | PART NO.       | QTY. | DESCRIPTION                        |
|------|----------------|------|------------------------------------|
| 1    | 3000269        | 2    | WASHER, FLAT 1/2 USS, SST          |
| 2    | 3008853        | 2    | SPRING, SPINNER CHUTE BAFFLE       |
| 3    | 3010172        | 1    | WELDMENT UPPER, CHUTE              |
| 4    | 3010202        | 2    | WELDMENT, DEFLECTOR INNER          |
| 5    | 3010278        | 2    | RETAINER, DEFLECTORS INNER         |
| 6    | 3012495        | 1    | WELDMENT, LOWER CHUTE BOTTOM MOTOR |
| 7    | 3012506        | 2    | BAFFLE SIDE, LOWER CHUTE           |
| 8    | 3012507        | 1    | BAFFLE REAR, LOWER CHUTE           |
| 9    | 3046931        | 1    | LABEL, CHUTE UPRIGHT               |
| 10   | 9240020        | 1    | SPINNER, 20" POLY CCW              |
| 11   | 9240131        | 1    | DECAL #1, DANGER STAY CLEAR        |
| 12   | 924F0017A      | 1    | ASSEMBLY, SPINNER HUB              |
| 13   | BCP84620SS     | 3    | PIN, CLEVIS 3/8 X 1.125 SST        |
| 14   | CM004P         | 1    | MOTOR, HYD 4 BOLT                  |
| 15   | FCB037516100SS | 6    | BOLT, 3/8-16 X 1 CARRIAGE SST      |
| 16   | FCS025020075SS | 4    | SCREW, CAP 1/4-20 X 3/4 SST        |
| 17   | FCS031018150SS | 4    | SCREW, HHC 5/16-18 X 1.5 SST       |
| 18   | FCS038016075SS | 4    | SCREW, HHC-3/8-16 X 3/4 SST        |
| 19   | FCS038016100SS | 6    | SCREW, HHC 3/8-16 X 1 304 SST      |
| 20   | FNE025020031SS | 4    | NUT, NYLON INSERT 1/4-20 SST       |
| 21   | FNE038016044SS | 6    | NUT, NYLOCK 3/8-16 X 7/16 SST      |
| 22   | FNH038016028SS | 6    | NUT, 3/8-16 HEX SST                |
| 23   | FPC019000125   | 2    | PIN, COTTER 3/16" X 1.25" ZN       |
| 24   | FPC009000075SS | 3    | PIN, COTTER 3/32 X 3/4 STAINLESS   |
| 25   | FWF025063007SS | 8    | WASHER, FLAT 1/4 SAE SS            |
| 26   | FWF031075006SS | 8    | WASHER, 5/16 SAE SST               |
| 27   | FWF038100007SS | 12   | WASHER, FLAT 3/8 USS SST           |
| 28   | FWL038069009SS | 10   | WASHER, LOCK RHS-3/8 SST           |

## Top Screen Assembly

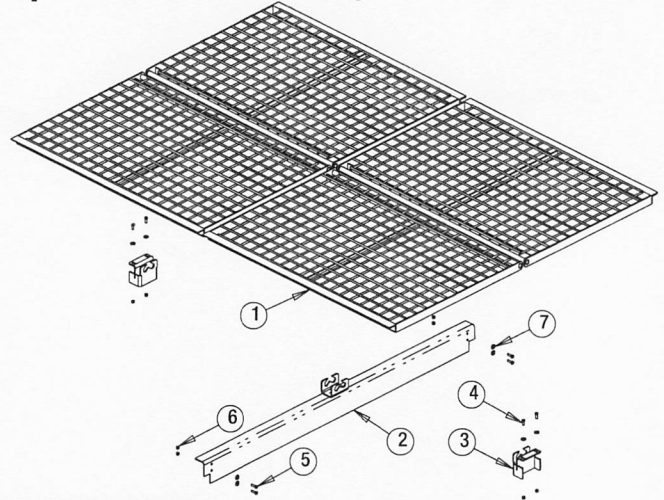

### Bill of Materials

| ITEM | PART NO.       | QTY. | DESCRIPTION                    |
|------|----------------|------|--------------------------------|
| 1    | 3010116        | 4    | GRATE, WELDED HOPPER TOP, 10FT |
|      | 3015554        | 6    | GRATE, WELDED HOPPER TOP, 12FT |
|      | 3015129        | 6    | GRATE, WELDED HOPPER TOP, 14FT |
| 2    | 3041322        | 1    | SUPPORT, FLAT SCREEN, WELDMENT |
| 3    | 3047211        | 2    | DETENT WELDM, FLAT SCREEN      |
| 4    | FCS038016100SS | 4    | SCREW, HHC 3/8-16 X 1 304 SST  |
| 5    | FCS038016125SS | 4    | SCREW, HHC-3/8-16 X 1.25 SST   |
| 6    | FNE038016044SS | 8    | NUT, NYLOCK 3/8-16 X 7/16 SST  |
| 7    | FWF038100007SS | 8    | WASHER, FLAT 3/8 USS SST       |

## Inverted V Assembly

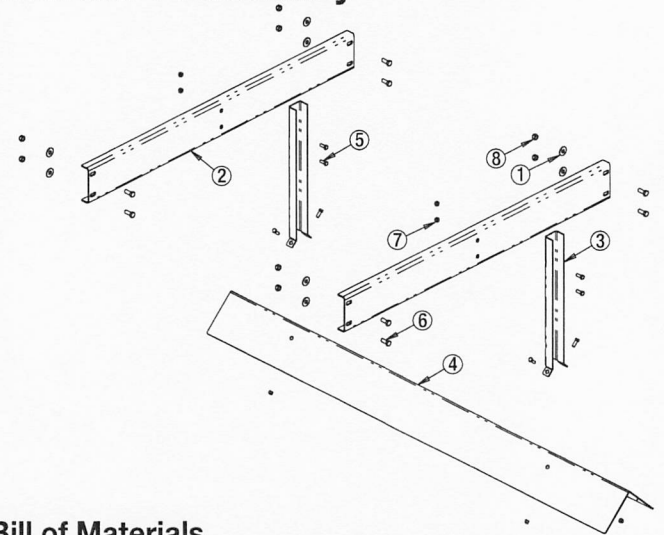

### Bill of Materials

| ITEM | PART NO.       | QTY. | DESCRIPTION                   |
|------|----------------|------|-------------------------------|
| 1    | 3000269        | 8    | WASHER, FLAT 1/2 USS, SST     |
| 2    | 3017730        | 2    | CROSS MEMBER, INVERTED VEE    |
| 3    | 3017731        | 2    | HANGER, INVERTED VEE          |
| 4    | 3028077        | 1    | DEFLECTOR, INVERTED VEE, 10FT |
|      | 3017729        | 1    | DEFLECTOR, INVERTED VEE, 12FT |
|      | 3047572        | 1    | DEFLECTOR, INVERTED VEE, 14FT |
| 5    | FCS038016100SS | 8    | SCREW, HHC 3/8-16 X 1 304 SST |
| 6    | FCS050013125SS | 8    | SCREW, HHC-1/2-13 X 1-1/4 SST |
| 7    | FNE038016044SS | 8    | NUT, NYLOCK 3/8-16 X 7/16 SST |
| 8    | FNE050013053SS | 8    | NUT, NYLOCK 1/2-13 SS         |

# American

EQUIPMENT CO.

SPECIALIZING IN TRUCK AND SNOW REMOVAL EQUIPMENT

JOHN BLOGIN

3250 Harvester Road  
Kansas City, KS 66115  
john@americanequipment.us

Bus. 913-342-1450  
Direct/Text 913-777-5783  
www.americanequipment.us

Page 105 of 206



**REQUEST FOR COMMISSION ACTION  
CITY OF INDEPENDENCE**

**April 23, 2026**

**Department Admin**

**Director Approval David Cowan**

**AGENDA ITEM** Consider proclaiming May 3-9, 2026 as Public Service Recognition Week.

**SUMMARY RECOMMENDATION** City staff recommends the Commission adopt the attached proclamation.

**BACKGROUND** Introduced in 1985 by President Reagan, Public Service Week honors the people in the public sector and acknowledges their efforts to provide services to the citizens. The City of Independence would like to honor our employees who provide services to the citizens of Independence. In addition, we would like to invite the City Commission to attend an appreciation luncheon for our employees on Tuesday, May 5, 2026 from 11 AM to 1 PM in the new Public Works facility. We also would like to invite the public to attend an open house for the for the new Public Works facility on Thursday, May 7, 2026 from 3 PM to 6 PM.

**FINANCIAL INFORMATION** N/A

**SUGGESTED MOTION** I move to authorize May 3-9, 2026, as Public Service Recognition Week in Independence, Kansas.

**SUPPORTING DOCUMENTS**

1. PUBLIC SERVICE RECOGNITION WEEK MAY 3-9 2026



## ***PUBLIC SERVICE RECOGNITION WEEK***

*In honor of the millions of public employees at the federal, state, county, and city levels:*

**Whereas:**

Americans are served every single day by public servants at the federal, state, county and city levels. These unsung heroes do the work that keeps our nation working;

**Whereas:**

Public employees take not only jobs, but oaths;

**Whereas:**

Many public servants, including military personnel, police officers, firefighters, EMT/paramedics, health care professionals and others, risk their lives each day in service to the people of the City of Independence, Montgomery County, State of Kansas, the United States and around the world;

**Whereas:**

Public servants include teachers, doctors and scientists ... ride operators and ticket sellers ... nurses, building and safety inspectors ... computer technicians, housing and social workers .. cemetery, park, and zoo workers ... public works and utility workers ... dispatchers, court and clerical workers and countless other occupations. Day in and day out they provide the diverse services demanded by the citizens of Independence of their government with efficiency and integrity; and

**Whereas:**

Without these public servants at every level, continuity would be impossible in a democracy that regularly changes its leaders and elected officials;

**Therefore:**

I, Dean A. Hayse, Mayor of Independence, Kansas do hereby announce and proclaim to all citizens and set seal hereto, that May 3-9, 2026, is Public Service Recognition Week in independence, Kansas. All citizens are encouraged to recognize the accomplishments and contributions of government employees at all levels serving the citizens of Independence, Kansas.



---

Mayor Dean A. Hayse



**CITY OF INDEPENDENCE**  
**April 23, 2026**

---

**Department**

**Director Approval**

**AGENDA ITEM** City Board Minutes

**BACKGROUND** NOTE: Do not use vague terms such as; "minor" or "numerous" that cannot be quantified.

**SUPPORTING DOCUMENTS**

1. January 28, 2026 IHPRC Meeting Minutes
2. February 3, 2026 Planning Commission/Board of Zoning Appeals Minutes
3. February 17, 2026 Independence Housing Authority Minutes
4. April 15, 2026 IRC Board Minutes

January 28, 2026  
Independence Historical Preservation and Resource Commission  
Meeting Minutes

Members Present: Darin Axthelm, Bill Gour, Brea Sanford, Ken Brown  
City Staff: David Cowan, Maurice Garlet  
Ex Officio: Lisa Wilson, Tabatha Snodgrass  
Absent: Jason Rutledge, Brett Richards, Gary Hogsett

Special Guest: Owner of Uncle Jack's

Darin Axthelm called the meeting to order at 12:00 p.m.

Brea Sanford made a motion to approve the January 12, 2026 meeting minutes as presented. Bill Gour seconded the motion, and all were in favor.

### **III. Action Items**

#### **A.) Uncle Jack's Transoms**

A letter asking the Commission to approve the following changes was written and read aloud by Tabatha Snodgrass.

Glass condition of the old transom windows above Uncle Jack's front doors isn't the best. Owner wants to protect what is left from further damage. To replace the transoms with historic glass- \$21,765. To replace with laminated safety glass- \$8,675; owner wants to replace with ACM planes over the original glass, which is removable.

Ken Brown thanked Tabatha for going to the Historical Society to make sure what changes could be done to keep the building within the historical downtown standards. He said that if Katrina (ShIPO) said it was okay to do and it will remain a contributing building to the historic downtown district, then that's fine by him. David Cowan reiterated that ShIPO had no concerns with the project.

It was asked if the transoms were functional and as of the moment, they are not and have not been functional in many years.

Darin Axthelm asked if they would be able to know if anything had penetrated the outer glass to damage the inner glass. Brea Sanford suggested yearly checks on the original glass. Owner said that the glass company had mentioned something about venting to decrease the chances of water damage. Bill Gour approved the changes. Brea Sanford seconded. All were in favor.

#### **b.) 111 East Main Street**

David Cowan shared that work had begun cleaning out the building. The second floor is gutted and there has been sealing around windows and they have primed the ceiling for paint. Owners plan to refresh the first floor, put in a new counter and paint tiles. It is a contributing building. They are working on signage, possible tuck pointing and will seal all windows. Owner will come back when there is more to approve. Building does have a new roof.

#### IV. Discussion

##### Girl Scout Cabin

Ken Brown reported that he had made a presentation at a FORPAZ meeting and feels that the park is the perfect location if it was decided to move the building and that FORPAZ could help with any fundraising efforts if they wanted to, since they are a 501(c)(3). He felt they were very receptive to the idea.

Brown continued, sharing that moving expenses were not eligible for tax credits, neither are foundations or sidewalks. SHIPO said that if the building would be registered now, it would cover rebuilding the chimney.

He has also contacted two separate movers in Kansas and is waiting for a call back from them. He proposed a shotgun approach- who has interest in it? Who has a vacant lot? Who has a 501(c)(3)? Owner of the building must submit an application to the State Registry and must keep the owner's name on title until a plan is made.

Bill Gour motioned to adjourn the meeting at 12:39 p.m. Ken Brown Seconded the motion. All were in favor.

**Minutes of the Planning and Zoning Commission/Board of Zoning Appeals's February 3, 2026 Meeting**

I. Call to Order

**City Commissioners Present:** Mayor Dean Hayse and Vice-Mayor Tim White

**Planning Commission/Zoning Board Present:** Rachel Lyon, Kym Kays, Michelle Avery, Tim Haynes, Gary Hogsett, Butch Holum, Rita Ortolani, Anita Chappuie and Bill Gour

**Absent:**

**City Staff Present:** David Cowan, Assistant City Manager; David Schwenker, City Clerk and Kayla Schabel, Executive Assistant to the City Manager

**Guests:**

Mayor Hayse called the meeting to order.

Chairperson Lyon called the meeting to order.

- a. Orientation by the City Attorney.

**This item was postponed to the March 3, 2026 meeting.**

- b. Reorganization

1. Election of Chair
2. Election of Vice Chair
3. Election of Secretary

**A Reorganization of Officers is generally held at the January meeting of each year. Due to vacancies that were not filled we delayed reorganization until the February meeting. We have a new member, Bill Gour, appointed to replace Lisa Richard on January 8, 2026. We wish to welcome Bill Gour and thank Lisa Richard for her service.**

**Motion:**

**On the motion of Gary Hogsett, seconded by Butch Holum, the Commission postponed reorganization to March 3, 2026.**

**Aye: Rachel Lyon, Kym Kays, Michelle Avery, Tim Haynes, Gary Hogsett, Butch Holum, Rita Ortolani, Anita Chappuie, Bill Gour**

**Nay: None**

**Minutes of the Planning and Zoning Commission/Board of Zoning Appeals's February 3, 2026 Meeting**

II. Discussion

- a. Joint Work Session: Discussion of Revised Landscaping Regulations (Article XIX) for the Zoning Code

**Kayla Schabel gave an overview of prior discussions.**

- b. Temporary Zoning Code Compilation (Appendix B – Zoning)

**An updated codification was included in the packet for the Commissioners and Board Members use since online codification will take 3–5 months.**

III. Minutes

- a. Consider approving minutes of the January 6th, 2026 meeting

**Motion:**

**On the motion of Tim Haynes, seconded by Rita Ortolani, the Commission approved the January 6th, 2026 minutes as presented.**

**Aye: Rachel Lyon, Kym Kays, Michelle Avery, Tim Haynes, Gary Hogsett, Butch Holum, Rita Ortolani, Anita Chappuie, Bill Gour**

**Nay: None**

IV. Board of Zoning Appeals (Does not include outside City appointments)

V. Planning Commission

- a. Consider modifying the 5:30 PM start time of the March 4, 2026 Planning Commission Meeting to 5:00 PM.

**As part of the City's Community-Based Strategic Plan, consultant Mackey Smith will be attending the Planning Commission's March 3, 2026, meeting to lead a focus group discussion. The purpose of the focus group is to gather input from Planning Commission members about the City's long-term priorities and goals.**

**To help fit in several focus groups that evening, the Planning Commission is being asked to start their meeting a little earlier at 5:00 PM instead of the usual 5:30 PM. This change will ensure there is enough time for the focus**

Minutes of the Planning and Zoning Commission/Board of Zoning Appeals's February 3, 2026 Meeting

group discussion to finish by 6:00 PM, allowing Mr. Smith to attend another scheduled session that night.

**Motion:**

On the motion of Anita Chappuie, seconded by Michelle Avery, the Commission modified the 5:30 PM start time of the Planning Commission meeting on March 3, 2026 to 5 PM.

**Aye:** Rachel Lyon, Kym Kays, Michelle Avery, Tim Haynes, Gary Hogsett, Butch Holum, Rita Ortolani, Anita Chappuie, Bill Gour

**Nay:** None

VI. Adjournment

**Motion:**

On the motion of Tim Haynes, seconded by Anita Chappuie, the Commission adjourned the meeting.

**Aye:** Rachel Lyon, Kym Kays, Michelle Avery, Tim Haynes, Gary Hogsett, Butch Holum, Rita Ortolani, Anita Chappuie, Bill Gour

**Nay:** None

  
\_\_\_\_\_  
Chair

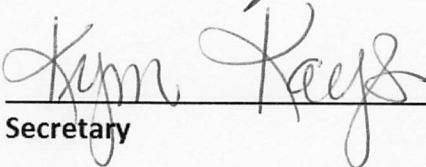
  
\_\_\_\_\_  
Secretary

MINUTES OF THE MEETING OF THE  
INDEPENDENCE HOUSING AUTHORITY

February 17, 2026  
Noon

Board Members in Attendance: Fred Meier, Darnell Lawrie, Cindy White, Rita Ortolani, and Charles Doerr.  
Personnel in Attendance: April Nutt

The meeting was called to order.

Doerr made a motion to approve the agenda Lawrie seconded the motion. The motion passed 5-0.

Doerr made a motion to approve January 20, 2026 and February 17, 2026 minutes. White seconded the motion. The motion passed 5-0.

Ortolani made a motion to approve the consent agenda. Doerr seconded the motion. The motion passed 5-0.

Budget Reports: Penn Terrace, Earl Street, and McKinley Housing.

IHA's Net Worth Report.

Bills for approval from January 21, 2026 and February 17, 2026.

Director's Report.

**Items Requiring Board Action**

White made a motion to approve Option 4A for installation of a new security camera system at Penn Terrace Apartments with additional cameras as needed. Ortolani seconded the motion. The motion passed 5-0.

Doerr motioned to approve accepting 10 lots from the Independence Land Bank for the development of 10 3D printed homes as part of the FHLB AHP grant program pending the Independence Land Bank approval. White seconded the motion. The motion passed 5-0.

Doerr made a motion to approve an agreement with Trident 3D Printed Homes and SeeKan CDI for the construction of a 3D printed model home. Lawrie seconded the motion. White abstained. The motion passed 4-0.

Ortolani made a motion to approve April Nutt's 2025 mileage and expense reimbursements. Doerr seconded the motion. The motion passed 5-0.

Consider authorizing Jeff Chubb, city attorney, to establish a LLC on behalf of the Independence Housing Authority to transfer the ownership of the Martin Estate Low-Income Tax Credit Project to the new entity. ---Tabled.

Ortolani made a motion to approve realtors eligible to participate in the sale of the Jefferson Subdivision Homes must meet the following criteria: Realtors must have a brick-and-mortar office within the city limits of Independence or within the Montgomery County Independence Zoned boundaries. Meier seconded. Lawrie abstained. White was not in attendance as she left the meeting prior to this item being brought before the board for approval. The motion passed 3-0.

**Communications**

Review 705 North Penn

Update on Jefferson Subdivision

Update on Rainbow Drive

Update on Upper Story Downtown Development

Meier made a motion to adjourn the meeting. Doerr seconded the motion. The motion passed 4-0.

# INDEPENDENCE RECREATION COMMISSION

## Board Meeting April 15th, 2026

Ash Youth Center  
1501 N. 10<sup>th</sup> Street  
Independence, KS 67301

### Members Present:

Greg Kelley

Mike Rose

Tanner McClure

Joe Housel

### Others Present:

Brent Julian

Simon Heckman

Galen Palmer

Chairperson, Greg Kelley opened the commission meeting at 11:30 a.m.

---

## ROUTINE BUSINESS

### Agenda

- Joe Housel moved to approve the agenda as printed. Tanner McClure seconded.
- **Motion carried.**

### Minutes

- Joe Housel moved to approve the minutes from the March 25th, 2026, board meeting. Tanner McClure seconded.
- **Motion carried.**

### Bills

- The board reviewed the bills for approval.
- Mike Rose moved to approve the March invoices and checks for payment in the amount of **\$25,430.67**, as well as employee benefits paid since the last board meeting in the amount of **\$11,197.88**. Joe Housel seconded.
- **Motion carried.**

### Treasurer's Report (Galen Palmer):

- **Financial Balances (End of March):**

- Petty Cash: \$500.00
- Equity Bank: \$196,196.23
- First Oak Balance: \$124,595.33
- **Two-Year Comparison (March):**
  - March 2025: \$321,891
  - March 2026: \$292,460
  - Favorable Difference: \$29,431
- Tanner McClure moved to approve the Treasurer's Report as presented. Mike Rose seconded.
- **Motion carried.**

---

## PROGRAMS AND OPERATIONS

### Maintenance Report

- **Staffing:** Ethan Speicher was commended for his exceptional work ethic, particularly during recent rain-affected tournaments.
- **Summer Help:** Dylan Cooley, a returning staff member, is scheduled to begin on May 19th.
- **Field Work:** Significant time has been spent mowing, marking fields and installing new field signage. Three new garage doors have been received for the concession stand and await installation.
- Board members discussed the potential for a future full-time maintenance position or permanent part-time help to alleviate the workload on Ethan and Brent.

### Sports Report (Nick McBride presented by Brent Julian):

#### Completed Programs & Recent Events

- **Second Session Basketball:** Concluded on Tuesday, February 24.
- **SEK All-Star Basketball Tournaments (March 9–13):**
  - **Boys' Division:** Featured 3 teams; **Caney** defeated Independence for the championship.
  - **Girls' Division:** Featured 4 teams; **Humboldt** defeated Neodesha in a double-elimination replay.

#### Pickleball & Spring Break Events

##### 11th Pickleball Tournament (March 7):

- Featured a record **16 teams** in the Men's Open division.
- Participants represented Independence, Bartlesville, Joplin, Chanute, Erie, and Altamont.

##### Ash Youth Center Spring Break Events:

- Daily activities included Free-throw knockout, a 7-game dodgeball series, and a 6-team double-elimination air hockey tournament

## Spring Season Outlook

- **Youth Soccer:** Registration closed March 12th with 312 total participants, an increase of 11 over last year. The season begins the week of April 13th at the Independence Soccer Complex.
- **Soccer Clinic:** Held March 21st with 74 participants, focusing on drills for players and ideas for coaches.
- **Flag Football:** Youth leagues reached 77 participants, with record-high registration numbers in the PeeWee and Junior Varsity divisions.
- **Co-Ed Volleyball:** Deadline was Friday, March 27th; season started April 12th.

## Future Registrations

### Upcoming Registration Dates:

- **Baseball/Softball:** Opened Monday, March 30th; deadline is April 30th.
- **Summer Leagues:** Registration for the **6v6 Summer Soccer League** and **5on5 High School & Up Flag Football** began April 6th.
- **Summer Swim Team and Swim Lessons:** Registration opens Monday April 28th. We are working to align registration periods for swim team and lessons with Baseball/Softball for better organization

## Director/Aquatics/Special Events Report (Brent Julian):

### Partnerships & Community Engagement

- **ICC Summer Internship Program:** A partnership has been established via an MOU with Independence Community College (ICC) for a summer internship program. The intern will work up to 20 hours per week, mentored by IRC staff, with compensation and insurance provided directly by ICC.
- **Jefferson School Rewards Day:** IRC hosted over 150 students from Jefferson School at the Ash Youth Center on April 7th for a four-hour event celebrating the completion of AR requirements.
- **Public Outreach:** Annual speaking engagements and tours are underway, including recent tours of the Central Park Sports Complex (CPSC) for Leadership Independence groups.

## RBFAC & Summer Preparation

- **Lifeguard Certification:** Rob Adolph certified 10 guards on April 12th–13th, with an additional 12 candidates scheduled for certification on April 25th–26th.
- **Training Standards:** Certifications are valid for two years through the Red Cross and cover Lifeguard, First Aid, CPR, and AED. Fees are set at \$150 for new guards and \$100 for recertification.
- **Financial Assistance:** IRC continues to support guards through summer payment plans and a qualification-based reimbursement bonus at the end of the season.

---

## BUSINESS / FINANCE

- **Love Independence Day Project:** The Commission is collaborating with the City Park department on projects such as trash pickup and clearing thickets. This year, the board will not be required to participate as a group.
- **Central Park Sports Complex Update:**
  - The complex is currently hosting high school teams, six travel teams, and various recreation leagues.
  - Field usage policies were clarified regarding "scrimmages" rental no longer required. Coaches are responsible for supervising prohibited activities like sunflower seeds and batting practice into fences.
  - Communication with local travel teams has improved, and field reservations are made directly with Brent.
- **Riverside Beach (RBFAC) 2026 Information:**
  - A persistent leak in the Lazy River is currently being investigated with the city. Testing drains one by one to isolate the issue before the scheduled opening on May 23rd.
- **Summer Staff Hiring:** The following positions have been filled for the 2026 season:
  - **Pool Manager:** Shawn O’Kane
  - **Assistant Pool Managers:** Cain Carpenter and Abby Cagle
  - **Swim Lessons Director:** Abby Cagle (succeeding the retired Gloria Price)
  - **Swim Team Coach:** Haley Marchant
  - **Tennis Director:** Ken Brown
  - **Grounds Crew:** Dylan Cooley
  - **Field Supervisors:** Sam Carnes and Samantha Ringle

---

## Executive Session

- There was no need for Executive Session

---

## ITEMS FROM THE COMMISSION:

- There were no items from the Commission

---

## AGREEMENT FOR ACTION ON ITEMS FROM THE COMMISSION:

- There were no action items from the Commission

---

## Adjournment

- Mike Rose motioned to adjourn the meeting. Joe Housel seconded.
- **Motion Carried.**
- **Meeting Adjourned:** 12:02 PM



**Report**  
**CITY OF INDEPENDENCE**  
**April 23, 2026**

---

**Department Public Works & Utilities**

**Director Approval John Garris**

**AGENDA ITEM** Public Works and Project Report

**BACKGROUND**

**SUPPORTING DOCUMENTS**

1. Project Status 4-2026cc

|    | Project Title                     | Project Description/Scope   | Approx. Cost (000's) | Grant Portion      | Arch. or Eng. Partner | Status                   | Last Month Progress  | Next Month Plan/Issues   | Projected Const Start | Projected Compl. |
|----|-----------------------------------|---|----------------------|--------------------|-----------------------|--------------------------|--|--|-----------------------|------------------|
| 1  | SS4A                              | Safe Streets for All grant: FHWA project to build new sidewalk, curb extensions, and miscellaneous safety improvements. | \$1,605              | \$1,605            | TBD                   | Pre-grant.               | Awaiting FHWA.   | Grant reviewed by FHWA, sent to legal for review.  | TBD                   | TBD              |
| 2  | Whiskey Creek                     | Artificial lake for runoff water impoundment  | TBD                  | TBD                | GFT                   | Conceptual Design.       | Requested status from USDA, KDEM grants are not available.   | Requested status from USDA, USDA requesting list of audits for City.   | TBD                   | TBD              |
| 3  | Water Distribution Strategic Plan | Review water distribution system for repairs and replacement.   | \$50                 | TBD                | EBH                   | Engineering in progress. | Revising draft.  | Received revised draft from engineering firm.  | 3Q26                  | 4Q36             |
| 4  | Runway 4/22                       | Mill and overlay Runway 4/22.   | \$1,600              | \$1,530            | Lochner               | Design.                  | Design in progress   | Design in progress   | 2Q26                  | 4Q27             |
| 5  | Water Plant Next Phase            | Water Plant Capital Work Per Master Plan  | \$9,500              | n/a                | PEC                   | Design.                  | Reviewing additional alternatives with KDHE.   | Loan pre-application RCA for next phase.   | 2Q26                  | 4Q29             |
| 6  | CCLIP Grant - 10th                | Reconstruct 10th between Main and Laurel  | \$1,700              | \$1,500            | GFT                   | Design.                  | Awaiting revised draft of traffic control program.   | Next City review of traffic control program.   | 4Q26                  | 3Q27             |
| 7  | SPCC - Airport                    | Containment upgrades for fueling  | \$150                | n/a                | GFT                   | Design.                  | Out for bid.   | No bids - evaluating contract changes.   | 2Q26                  | 3Q26             |
| 8  | Penn and Chestnut                 | Rebuild corner to accommodate drainage.   | TBD                  | TBD                | GFT                   | Design complete.         | Discussing funding.  | Discussing funding.  | 2Q26                  | 3Q26             |
| 9  | Dam Review And Repair             | Design dam diversion structure and bid required repairs.  | \$750                | n/a                | WRS                   | Design/Inspection.       | Engineering firm planning further inspection.  | Engineering firm planning further inspection at lower water flows.   | 3Q26                  | 1Q27             |
| 10 | KAIP - Apron Rehab                | Apron rehab near Textron operations.  | \$636                | \$572              | Lochner               | Pre-award.               | Requesting Commission permission to award project.   | Awaiting project contract documents.   | 2Q26                  | 3Q26             |
| 11 | Transp. Alt. Grant                | 8' sidewalk to Wal-Mart and Labette   | \$1,350              | \$980              | GFT                   | Pre-construction.        | Await precon. Project scheduled to start in July.  | Await precon. Project scheduled to start in July.  | 3Q26                  | 4Q26             |
| 12 | KDHE Wastewater Loan              | New sewer lines around 1st and Birch and around the Westminster area.   | \$3,000              | TBD                | GFT                   | In construction.         | Project ongoing.   | Project ongoing.   | 1Q26                  | 3Q26             |
| 13 | Memorial Hall HVAC                | Cooling system replacement at Memorial Hall.  | \$500                | TBD                | LSA                   | In construction.         | Construction in progress.  | Construction in progress.  | 4Q25                  | 2Q26             |
| 14 | Enterprise Drive                  | Buildout of street, utilities   | \$1,700              | \$1,300            | GFT                   | In construction.         | Schedule work, waiting on AT&T. Set up "re" precon with Graham                                       | AT&T waiting on subcontractor. Set up "re" precon with Graham  | 1Q22                  | 2Q26             |
| 15 | Big Straw                         | Water pipeline to Bartlett.   | \$11,000             | All (via Bartlett) | EBH                   | In construction.         | Pump station commissioning started, water tower in place, working on controls and SCADA integration. | Pump station in service. Water tank in service. Waiting on instrumentation delivery to complete commissioning and SCADA integration. | 4Q23                  | 2Q26             |
| 16 | Waterline/Meter Project           | New Water Meters, Replace Some Water Main   | \$3,600              | n/a                | PEC                   | In construction.         | Meters(all but 5) installed, substantially complete, working data issues.                            | Meters(all but 5) installed, substantially complete, working data issues.  | 1Q24                  | 3Q25             |
| A  | 2026 ADA                          | ADA work at various locations.  | TBD                  | TBD                | GFT                   | Developing.              | Evaluating engineering proposal.   | Discussing funding.  | 2Q26                  | 3Q26             |
| B  | Airport Signs                     | Replace various directional signs at the airport.   | TBD                  | TBD                | Lochner               | Developing.              | Application submitted.   | Application submitted.   | TBD                   | TBD              |
| C  | 2028 CCLIP                        | 2028 CCLIP application, E. Main, 2nd to City Limits.  | TBD                  | TBD                | Lochner               | Developing.              | Application prepared.  |  | TBD                   | TBD              |

Green shade denotes changed/new information from last month.



**Report**  
**CITY OF INDEPENDENCE**  
**April 23, 2026**

---

**Department Finance**

**Director Approval Lacey Lies**

**AGENDA ITEM** Appropriations

**BACKGROUND**

**SUPPORTING DOCUMENTS**

1. AP 3-15-2026
2. AP 3-31-2026
3. MARCH 2026 DRAFT
4. PAYROLL 3-13-2026
5. PAYROLL 3-27-2026

**APPROPRIATIONS 2026**

Accounts payable paid from March 1st, 2026, through March 15th, 2026.

Total: \$1,666,187.26



Bank: General - Community National Bank

|                      |                       |                     |                            |
|----------------------|-----------------------|---------------------|----------------------------|
| <b>Vendor Number</b> | <b>Vendor Name</b>    |                     | <b>Total Vendor Amount</b> |
|                      | **Void**              |                     | 0.00                       |
| <b>Payment Type</b>  | <b>Payment Number</b> | <b>Payment Date</b> | <b>Payment Amount</b>      |
| **Void Check         | <a href="#">80826</a> | 03/02/2026          | 0.00                       |

|                        |                       |                     |                            |
|------------------------|-----------------------|---------------------|----------------------------|
| <b>Vendor Number</b>   | <b>Vendor Name</b>    |                     | <b>Total Vendor Amount</b> |
| <a href="#">035778</a> | 8th & Main Historic   |                     | 1,435.00                   |
| <b>Payment Type</b>    | <b>Payment Number</b> | <b>Payment Date</b> | <b>Payment Amount</b>      |
| EFT                    | <a href="#">9315</a>  | 03/02/2026          | 1,435.00                   |

| Payable Number | Description      | Payable Date | Due Date   | Discount Amount | Payable Amount |
|----------------|------------------|--------------|------------|-----------------|----------------|
| [REDACTED]     | 123 W. Main #303 | 03/01/2026   | 03/10/2026 | 0.00            | 359.00         |
| [REDACTED]     | 123 W MAIN #205  | 03/01/2026   | 03/10/2026 | 0.00            | 283.00         |
| [REDACTED]     | 123 W MAIN #301  | 03/01/2026   | 03/10/2026 | 0.00            | 370.00         |
| [REDACTED]     | 123 W. Main #101 | 03/01/2026   | 03/10/2026 | 0.00            | 423.00         |

|                        |                       |                     |                            |
|------------------------|-----------------------|---------------------|----------------------------|
| <b>Vendor Number</b>   | <b>Vendor Name</b>    |                     | <b>Total Vendor Amount</b> |
| <a href="#">002100</a> | A.W.O.L.              |                     | 3,150.00                   |
| <b>Payment Type</b>    | <b>Payment Number</b> | <b>Payment Date</b> | <b>Payment Amount</b>      |
| EFT                    | <a href="#">9316</a>  | 03/02/2026          | 3,150.00                   |

| Payable Number             | Description   | Payable Date | Due Date   | Discount Amount | Payable Amount |
|----------------------------|---------------|--------------|------------|-----------------|----------------|
| <a href="#">INV0004966</a> | AWOL CONTRACT | 03/01/2026   | 03/01/2026 | 0.00            | 3,150.00       |

|                        |                            |                     |                            |
|------------------------|----------------------------|---------------------|----------------------------|
| <b>Vendor Number</b>   | <b>Vendor Name</b>         |                     | <b>Total Vendor Amount</b> |
| <a href="#">034882</a> | Christopher David Mitchell |                     | 324.00                     |
| <b>Payment Type</b>    | <b>Payment Number</b>      | <b>Payment Date</b> | <b>Payment Amount</b>      |
| EFT                    | <a href="#">9317</a>       | 03/02/2026          | 324.00                     |

| Payable Number | Description | Payable Date | Due Date   | Discount Amount | Payable Amount |
|----------------|-------------|--------------|------------|-----------------|----------------|
| [REDACTED]     | 917 E HILL  | 03/01/2026   | 03/10/2026 | 0.00            | 324.00         |

|                        |                       |                     |                            |
|------------------------|-----------------------|---------------------|----------------------------|
| <b>Vendor Number</b>   | <b>Vendor Name</b>    |                     | <b>Total Vendor Amount</b> |
| <a href="#">035632</a> | Class Ltd             |                     | 35.00                      |
| <b>Payment Type</b>    | <b>Payment Number</b> | <b>Payment Date</b> | <b>Payment Amount</b>      |
| EFT                    | <a href="#">9318</a>  | 03/02/2026          | 35.00                      |

| Payable Number | Description | Payable Date | Due Date   | Discount Amount | Payable Amount |
|----------------|-------------|--------------|------------|-----------------|----------------|
| [REDACTED]     | 309 CEMENT  | 03/01/2026   | 03/01/2026 | 0.00            | 35.00          |

|                        |                               |                     |                            |
|------------------------|-------------------------------|---------------------|----------------------------|
| <b>Vendor Number</b>   | <b>Vendor Name</b>            |                     | <b>Total Vendor Amount</b> |
| <a href="#">038156</a> | Divine Equity Consultants LLC |                     | 817.00                     |
| <b>Payment Type</b>    | <b>Payment Number</b>         | <b>Payment Date</b> | <b>Payment Amount</b>      |
| EFT                    | <a href="#">9319</a>          | 03/02/2026          | 817.00                     |

| Payable Number | Description     | Payable Date | Due Date   | Discount Amount | Payable Amount |
|----------------|-----------------|--------------|------------|-----------------|----------------|
| [REDACTED]     | 1200 1/2 N. 6th | 03/01/2026   | 03/01/2026 | 0.00            | 399.00         |
| [REDACTED]     | 425 S 16th      | 03/01/2026   | 03/01/2026 | 0.00            | 418.00         |

|                        |                       |                     |                            |
|------------------------|-----------------------|---------------------|----------------------------|
| <b>Vendor Number</b>   | <b>Vendor Name</b>    |                     | <b>Total Vendor Amount</b> |
| <a href="#">038113</a> | Elizabeth Hager       |                     | 511.00                     |
| <b>Payment Type</b>    | <b>Payment Number</b> | <b>Payment Date</b> | <b>Payment Amount</b>      |
| EFT                    | <a href="#">9320</a>  | 03/02/2026          | 511.00                     |

| Payable Number | Description     | Payable Date | Due Date   | Discount Amount | Payable Amount |
|----------------|-----------------|--------------|------------|-----------------|----------------|
| [REDACTED]     | 421 S. 14th St. | 03/01/2026   | 03/10/2026 | 0.00            | 511.00         |

**Payment Register**

**APPKT01835 - March 2026 1st of the month bills**

|   |  |                                   |                               |                                   |  |  |
|---|--|-----------------------------------|-------------------------------|-----------------------------------|--|--|
| <b>Vendor Number</b><br><a href="#">035721</a>      | <b>Vendor Name</b><br>Emert Chubb LLC            |                                   |                               |                                   |  | <b>Total Vendor Amount</b><br>3,949.73 |
| <b>Payment Type</b><br>EFT                          | <b>Payment Number</b><br><a href="#">9321</a>    |                                   |                               | <b>Payment Date</b><br>03/02/2026 |  | <b>Payment Amount</b><br>3,949.73      |
| <b>Payable Number</b><br><a href="#">INV0004963</a> | <b>Description</b><br>MUNICIPAL COURT PROSECUTOR | <b>Payable Date</b><br>03/01/2026 | <b>Due Date</b><br>03/01/2026 | <b>Discount Amount</b><br>0.00    |  | <b>Payable Amount</b><br>3,949.73      |

|   |   |                                   |                               |                                   |  |                                      |
|---|---|-----------------------------------|-------------------------------|-----------------------------------|--|--------------------------------------|
| <b>Vendor Number</b><br><a href="#">033777</a>      | <b>Vendor Name</b><br>Independence Gun Club   |                                   |                               |                                   |  | <b>Total Vendor Amount</b><br>121.59 |
| <b>Payment Type</b><br>EFT                          | <b>Payment Number</b><br><a href="#">9322</a> |                                   |                               | <b>Payment Date</b><br>03/02/2026 |  | <b>Payment Amount</b><br>121.59      |
| <b>Payable Number</b><br><a href="#">INV0004958</a> | <b>Description</b><br>Monthly Payment         | <b>Payable Date</b><br>03/01/2026 | <b>Due Date</b><br>03/01/2026 | <b>Discount Amount</b><br>0.00    |  | <b>Payable Amount</b><br>121.59      |

|   |   |                                   |                               |                                   |  |  |
|---|---|-----------------------------------|-------------------------------|-----------------------------------|--|--|
| <b>Vendor Number</b><br><a href="#">032735</a>      | <b>Vendor Name</b><br>Independence Historical   |                                   |                               |                                   |  | <b>Total Vendor Amount</b><br>1,425.00 |
| <b>Payment Type</b><br>EFT                          | <b>Payment Number</b><br><a href="#">9323</a>   |                                   |                               | <b>Payment Date</b><br>03/02/2026 |  | <b>Payment Amount</b><br>1,425.00      |
| <b>Payable Number</b><br><a href="#">INV0004962</a> | <b>Description</b><br>HISTORICAL MUSEUM SUPPORT | <b>Payable Date</b><br>03/01/2026 | <b>Due Date</b><br>03/01/2026 | <b>Discount Amount</b><br>0.00    |  | <b>Payable Amount</b><br>1,425.00      |

|  |  |                     |                 |                                   |  |  |
|--|--|---------------------|-----------------|-----------------------------------|--|--|
| <b>Vendor Number</b><br><a href="#">030108</a> | <b>Vendor Name</b><br>Independence Housing Authority |                     |                 |                                   |  | <b>Total Vendor Amount</b><br>4,539.00 |
| <b>Payment Type</b><br>Check                   | <b>Payment Number</b><br><a href="#">80825</a>       |                     |                 | <b>Payment Date</b><br>03/02/2026 |  | <b>Payment Amount</b><br>4,539.00      |
| <b>Payable Number</b>                          | <b>Description</b>                                   | <b>Payable Date</b> | <b>Due Date</b> | <b>Discount Amount</b>            |  | <b>Payable Amount</b>                  |
| [REDACTED]                                     | 922 E COFFEYVILLE #C                                 | 03/01/2026          | 03/10/2026      | 0.00                              |  | 262.00                                 |
| [REDACTED]                                     | 916 E CEDAR #3                                       | 03/01/2026          | 03/10/2026      | 0.00                              |  | 231.00                                 |
| [REDACTED]                                     | 710 N 13TH ST  | 03/01/2026          | 03/01/2026      | 0.00                              |  | 626.00                                 |
| [REDACTED]                                     | 1008 E. Coffeyville #A                               | 03/01/2026          | 03/10/2026      | 0.00                              |  | 89.00                                  |
| [REDACTED]                                     | 404 S Earl   | 03/01/2026          | 03/31/2026      | 0.00                              |  | 1,102.00                               |
| [REDACTED]                                     | 922 E Coffeyville #B                                 | 03/01/2026          | 03/10/2026      | 0.00                              |  | 205.00                                 |
| [REDACTED]                                     | 702 N 13th   | 03/01/2026          | 03/10/2026      | 0.00                              |  | 272.00                                 |
| [REDACTED]                                     | 1009 E CEDAR #A                                      | 03/01/2026          | 03/10/2026      | 0.00                              |  | 255.00                                 |
| [REDACTED]                                     | 1008 E Coffeyville #C                                | 03/01/2026          | 03/31/2026      | 0.00                              |  | 119.00                                 |
| [REDACTED]                                     | 916 E CEDAR #2                                       | 03/01/2026          | 03/10/2026      | 0.00                              |  | 166.00                                 |
| [REDACTED]                                     | 1009 E CEDAR #B                                      | 03/01/2026          | 03/10/2026      | 0.00                              |  | 199.00                                 |
| [REDACTED]                                     | 706 N 13th   | 03/01/2026          | 03/31/2026      | 0.00                              |  | 94.00                                  |
| [REDACTED]                                     | 923 E CEDAR #C                                       | 03/01/2026          | 03/10/2026      | 0.00                              |  | 197.00                                 |
| [REDACTED]                                     | 923 E CEDAR #B                                       | 03/01/2026          | 03/01/2026      | 0.00                              |  | 306.00                                 |
| [REDACTED]                                     | 718 N 13TH   | 03/01/2026          | 03/10/2026      | 0.00                              |  | 182.00                                 |
| [REDACTED]                                     | 923 E CEDAR #A                                       | 03/01/2026          | 03/10/2026      | 0.00                              |  | 234.00                                 |

|   |  |                                   |                               |                                   |  |  |
|---|--|-----------------------------------|-------------------------------|-----------------------------------|--|--|
| <b>Vendor Number</b><br><a href="#">011215</a>      | <b>Vendor Name</b><br>Independence Main Street     |                                   |                               |                                   |  | <b>Total Vendor Amount</b><br>3,000.00 |
| <b>Payment Type</b><br>EFT                          | <b>Payment Number</b><br><a href="#">9324</a>      |                                   |                               | <b>Payment Date</b><br>03/02/2026 |  | <b>Payment Amount</b><br>3,000.00      |
| <b>Payable Number</b><br><a href="#">INV0004965</a> | <b>Description</b><br>FUNDING FOR INDEP. MAIN STR. | <b>Payable Date</b><br>03/01/2026 | <b>Due Date</b><br>03/01/2026 | <b>Discount Amount</b><br>0.00    |  | <b>Payable Amount</b><br>3,000.00      |

|   |  |                                   |                               |                                   |  |  |
|---|--|-----------------------------------|-------------------------------|-----------------------------------|--|--|
| <b>Vendor Number</b><br><a href="#">011280</a>      | <b>Vendor Name</b><br>Independence Recreation Commission |                                   |                               |                                   |  | <b>Total Vendor Amount</b><br>2,000.00 |
| <b>Payment Type</b><br>EFT                          | <b>Payment Number</b><br><a href="#">9325</a>            |                                   |                               | <b>Payment Date</b><br>03/02/2026 |  | <b>Payment Amount</b><br>2,000.00      |
| <b>Payable Number</b><br><a href="#">INV0004961</a> | <b>Description</b><br>ASH ALLOTMENT                      | <b>Payable Date</b><br>03/01/2026 | <b>Due Date</b><br>03/10/2026 | <b>Discount Amount</b><br>0.00    |  | <b>Payable Amount</b><br>2,000.00      |

Payment Register

APPKT01835 - March 2026 1st of the month bills

|                            |                           |                     |                 |                        |                       |  |                            |
|----------------------------|---------------------------|---------------------|-----------------|------------------------|-----------------------|--|----------------------------|
| <b>Vendor Number</b>       | <b>Vendor Name</b>        |                     |                 |                        |                       |  | <b>Total Vendor Amount</b> |
| <a href="#">004497</a>     | Jeff Chubb - C/O Emert    |                     |                 |                        |                       |  | 6,076.49                   |
| <b>Payment Type</b>        | <b>Payment Number</b>     |                     |                 | <b>Payment Date</b>    | <b>Payment Amount</b> |  |                            |
| EFT                        | <a href="#">9326</a>      |                     |                 | 03/02/2026             | 6,076.49              |  |                            |
| <b>Payable Number</b>      | <b>Description</b>        | <b>Payable Date</b> | <b>Due Date</b> | <b>Discount Amount</b> | <b>Payable Amount</b> |  |                            |
| <a href="#">INV0004967</a> | CITY ATTORNEY'S FEES      | 03/01/2026          | 03/01/2026      | 0.00                   | 6,076.49              |  |                            |
| <b>Vendor Number</b>       | <b>Vendor Name</b>        |                     |                 |                        |                       |  | <b>Total Vendor Amount</b> |
| <a href="#">038129</a>     | Jeffrey Wheat             |                     |                 |                        |                       |  | 150.00                     |
| <b>Payment Type</b>        | <b>Payment Number</b>     |                     |                 | <b>Payment Date</b>    | <b>Payment Amount</b> |  |                            |
| Check                      | <a href="#">80827</a>     |                     |                 | 03/02/2026             | 150.00                |  |                            |
| <b>Payable Number</b>      | <b>Description</b>        | <b>Payable Date</b> | <b>Due Date</b> | <b>Discount Amount</b> | <b>Payable Amount</b> |  |                            |
| <a href="#">INV0004964</a> | Penn Terrace On - Call    | 03/01/2026          | 03/10/2026      | 0.00                   | 150.00                |  |                            |
| <b>Vendor Number</b>       | <b>Vendor Name</b>        |                     |                 |                        |                       |  | <b>Total Vendor Amount</b> |
| <a href="#">037363</a>     | Joslyn M Kusiak           |                     |                 |                        |                       |  | 3,539.70                   |
| <b>Payment Type</b>        | <b>Payment Number</b>     |                     |                 | <b>Payment Date</b>    | <b>Payment Amount</b> |  |                            |
| EFT                        | <a href="#">9327</a>      |                     |                 | 03/02/2026             | 3,539.70              |  |                            |
| <b>Payable Number</b>      | <b>Description</b>        | <b>Payable Date</b> | <b>Due Date</b> | <b>Discount Amount</b> | <b>Payable Amount</b> |  |                            |
| <a href="#">INV0004960</a> | MUNICIPAL COURT JUDGE     | 03/01/2026          | 03/01/2026      | 0.00                   | 3,539.70              |  |                            |
| <b>Vendor Number</b>       | <b>Vendor Name</b>        |                     |                 |                        |                       |  | <b>Total Vendor Amount</b> |
| <a href="#">032485</a>     | Kelly C. Passauer         |                     |                 |                        |                       |  | 107.70                     |
| <b>Payment Type</b>        | <b>Payment Number</b>     |                     |                 | <b>Payment Date</b>    | <b>Payment Amount</b> |  |                            |
| EFT                        | <a href="#">9328</a>      |                     |                 | 03/02/2026             | 107.70                |  |                            |
| <b>Payable Number</b>      | <b>Description</b>        | <b>Payable Date</b> | <b>Due Date</b> | <b>Discount Amount</b> | <b>Payable Amount</b> |  |                            |
| <a href="#">INV0004968</a> | KPERS OGLI REIMBURSEMENT  | 03/01/2026          | 03/01/2026      | 0.00                   | 107.70                |  |                            |
| <b>Vendor Number</b>       | <b>Vendor Name</b>        |                     |                 |                        |                       |  | <b>Total Vendor Amount</b> |
| <a href="#">038221</a>     | Lotus Investment Fund LLC |                     |                 |                        |                       |  | 259.00                     |
| <b>Payment Type</b>        | <b>Payment Number</b>     |                     |                 | <b>Payment Date</b>    | <b>Payment Amount</b> |  |                            |
| EFT                        | <a href="#">9329</a>      |                     |                 | 03/02/2026             | 259.00                |  |                            |
| <b>Payable Number</b>      | <b>Description</b>        | <b>Payable Date</b> | <b>Due Date</b> | <b>Discount Amount</b> | <b>Payable Amount</b> |  |                            |
| [REDACTED]                 | 213 W Locust              | 03/01/2026          | 04/01/2026      | 0.00                   | 259.00                |  |                            |
| <b>Vendor Number</b>       | <b>Vendor Name</b>        |                     |                 |                        |                       |  | <b>Total Vendor Amount</b> |
| <a href="#">036893</a>     | Martin Estates LLC        |                     |                 |                        |                       |  | 829.00                     |
| <b>Payment Type</b>        | <b>Payment Number</b>     |                     |                 | <b>Payment Date</b>    | <b>Payment Amount</b> |  |                            |
| EFT                        | <a href="#">9330</a>      |                     |                 | 03/02/2026             | 829.00                |  |                            |
| <b>Payable Number</b>      | <b>Description</b>        | <b>Payable Date</b> | <b>Due Date</b> | <b>Discount Amount</b> | <b>Payable Amount</b> |  |                            |
| [REDACTED]                 | 818 LANDON                | 03/01/2026          | 03/10/2026      | 0.00                   | 284.00                |  |                            |
| [REDACTED]                 | 824 LANDON                | 03/01/2026          | 03/01/2026      | 0.00                   | 545.00                |  |                            |
| <b>Vendor Number</b>       | <b>Vendor Name</b>        |                     |                 |                        |                       |  | <b>Total Vendor Amount</b> |
| <a href="#">015680</a>     | Mid Continent Band        |                     |                 |                        |                       |  | 700.00                     |
| <b>Payment Type</b>        | <b>Payment Number</b>     |                     |                 | <b>Payment Date</b>    | <b>Payment Amount</b> |  |                            |
| EFT                        | <a href="#">9331</a>      |                     |                 | 03/02/2026             | 700.00                |  |                            |
| <b>Payable Number</b>      | <b>Description</b>        | <b>Payable Date</b> | <b>Due Date</b> | <b>Discount Amount</b> | <b>Payable Amount</b> |  |                            |
| <a href="#">INV0004959</a> | MONTHLY PAYMENT           | 03/01/2026          | 03/01/2026      | 0.00                   | 700.00                |  |                            |
| <b>Vendor Number</b>       | <b>Vendor Name</b>        |                     |                 |                        |                       |  | <b>Total Vendor Amount</b> |
| <a href="#">038292</a>     | Pioneer Creek LLC         |                     |                 |                        |                       |  | 377.00                     |
| <b>Payment Type</b>        | <b>Payment Number</b>     |                     |                 | <b>Payment Date</b>    | <b>Payment Amount</b> |  |                            |
| EFT                        | <a href="#">9332</a>      |                     |                 | 03/02/2026             | 377.00                |  |                            |
| <b>Payable Number</b>      | <b>Description</b>        | <b>Payable Date</b> | <b>Due Date</b> | <b>Discount Amount</b> | <b>Payable Amount</b> |  |                            |
| [REDACTED]                 | 2325 N 20th Pl #9         | 03/01/2026          | 04/01/2026      | 0.00                   | 377.00                |  |                            |

**Payment Register**

**APPKT01835 - March 2026 1st of the month bills**

| Vendor Number          | Vendor Name                         |  |                     |                     |                        | Total Vendor Amount   |
|------------------------|-------------------------------------|--|---------------------|---------------------|------------------------|-----------------------|
| <a href="#">038338</a> | Real Estate Center                  |  |                     |                     |                        | 201.00                |
| <b>Payment Type</b>    | <b>Payment Number</b>               |  |                     | <b>Payment Date</b> | <b>Payment Amount</b>  |                       |
| Check                  | <a href="#">80828</a>               |  |                     | 03/02/2026          | 201.00                 |                       |
| <b>Payable Number</b>  | <b>Description</b>                  |  | <b>Payable Date</b> | <b>Due Date</b>     | <b>Discount Amount</b> | <b>Payable Amount</b> |
| [REDACTED]             | 509 E. Birch                        |  | 03/01/2026          | 03/01/2026          | 0.00                   | 201.00                |
| <a href="#">034739</a> | Robert Pasternak                    |  |                     |                     |                        | 327.00                |
| <b>Payment Type</b>    | <b>Payment Number</b>               |  |                     | <b>Payment Date</b> | <b>Payment Amount</b>  |                       |
| EFT                    | <a href="#">9333</a>                |  |                     | 03/02/2026          | 327.00                 |                       |
| <b>Payable Number</b>  | <b>Description</b>                  |  | <b>Payable Date</b> | <b>Due Date</b>     | <b>Discount Amount</b> | <b>Payable Amount</b> |
| [REDACTED]             | 603 S 1st St                        |  | 03/01/2026          | 04/01/2026          | 0.00                   | 327.00                |
| <a href="#">038195</a> | Rural Housing of Independence, LP   |  |                     |                     |                        | 387.00                |
| <b>Payment Type</b>    | <b>Payment Number</b>               |  |                     | <b>Payment Date</b> | <b>Payment Amount</b>  |                       |
| EFT                    | <a href="#">9334</a>                |  |                     | 03/02/2026          | 387.00                 |                       |
| <b>Payable Number</b>  | <b>Description</b>                  |  | <b>Payable Date</b> | <b>Due Date</b>     | <b>Discount Amount</b> | <b>Payable Amount</b> |
| [REDACTED]             | 1701 N. 10th Apt. 32                |  | 03/01/2026          | 04/08/2026          | 0.00                   | 387.00                |
| <a href="#">038293</a> | Steadfast Properties LLC            |  |                     |                     |                        | 403.00                |
| <b>Payment Type</b>    | <b>Payment Number</b>               |  |                     | <b>Payment Date</b> | <b>Payment Amount</b>  |                       |
| EFT                    | <a href="#">9335</a>                |  |                     | 03/02/2026          | 403.00                 |                       |
| <b>Payable Number</b>  | <b>Description</b>                  |  | <b>Payable Date</b> | <b>Due Date</b>     | <b>Discount Amount</b> | <b>Payable Amount</b> |
| [REDACTED]             | 319 S 9th                           |  | 03/01/2026          | 04/01/2026          | 0.00                   | 403.00                |
| <a href="#">038099</a> | Ted A. Kuehl                        |  |                     |                     |                        | 375.00                |
| <b>Payment Type</b>    | <b>Payment Number</b>               |  |                     | <b>Payment Date</b> | <b>Payment Amount</b>  |                       |
| EFT                    | <a href="#">9336</a>                |  |                     | 03/02/2026          | 375.00                 |                       |
| <b>Payable Number</b>  | <b>Description</b>                  |  | <b>Payable Date</b> | <b>Due Date</b>     | <b>Discount Amount</b> | <b>Payable Amount</b> |
| [REDACTED]             | 512 Charlotte                       |  | 03/01/2026          | 03/10/2026          | 0.00                   | 375.00                |
| <a href="#">037725</a> | Terry Hon                           |  |                     |                     |                        | 625.00                |
| <b>Payment Type</b>    | <b>Payment Number</b>               |  |                     | <b>Payment Date</b> | <b>Payment Amount</b>  |                       |
| EFT                    | <a href="#">9337</a>                |  |                     | 03/02/2026          | 625.00                 |                       |
| <b>Payable Number</b>  | <b>Description</b>                  |  | <b>Payable Date</b> | <b>Due Date</b>     | <b>Discount Amount</b> | <b>Payable Amount</b> |
| [REDACTED]             | 1600 HALSEY AVE                     |  | 03/01/2026          | 03/10/2026          | 0.00                   | 625.00                |
| <a href="#">037258</a> | Washington Historic Residences, LLC |  |                     |                     |                        | 503.00                |
| <b>Payment Type</b>    | <b>Payment Number</b>               |  |                     | <b>Payment Date</b> | <b>Payment Amount</b>  |                       |
| EFT                    | <a href="#">9338</a>                |  |                     | 03/02/2026          | 503.00                 |                       |
| <b>Payable Number</b>  | <b>Description</b>                  |  | <b>Payable Date</b> | <b>Due Date</b>     | <b>Discount Amount</b> | <b>Payable Amount</b> |
| [REDACTED]             | 300 E MYRTLE #112                   |  | 03/01/2026          | 03/10/2026          | 0.00                   | 154.00                |
| [REDACTED]             | 300 E. Myrtle #202                  |  | 03/01/2026          | 03/10/2026          | 0.00                   | 349.00                |

### Payment Summary

| Bank Code             | Type                | Payable<br>Count | Payment<br>Count | Discount    | Payment          |
|-----------------------|---------------------|------------------|------------------|-------------|------------------|
| General               | Check               | 18               | 3                | 0.00        | 4,890.00         |
| General               | Voided **Void Check | 0                | 1                | 0.00        | 0.00             |
| General               | EFT                 | 30               | 24               | 0.00        | 31,277.21        |
| <b>Packet Totals:</b> |                     | <b>48</b>        | <b>28</b>        | <b>0.00</b> | <b>36,167.21</b> |

### Cash Fund Summary

| Fund                  | Name        | Amount            |
|-----------------------|-------------|-------------------|
| 099                   | Pooled Cash | -36,167.21        |
| <b>Packet Totals:</b> |             | <u>-36,167.21</u> |



Bank: General - Community National Bank

| Vendor Number         | Vendor Name           |                     |                 |                        |                       |                       | Total Vendor Amount |
|-----------------------|-----------------------|---------------------|-----------------|------------------------|-----------------------|-----------------------|---------------------|
|                       | **Void**              |                     |                 |                        |                       |                       | 0.00                |
| <b>Payment Type</b>   | <b>Payment Number</b> |                     |                 | <b>Payment Date</b>    |                       | <b>Payment Amount</b> |                     |
| **Void EFT            | <a href="#">9351</a>  |                     |                 | 03/06/2026             |                       | 0.00                  |                     |
| <b>Payable Number</b> | <b>Description</b>    | <b>Payable Date</b> | <b>Due Date</b> | <b>Discount Amount</b> | <b>Payable Amount</b> |                       |                     |
|                       |                       |                     |                 | 0.00                   | 0.00                  |                       |                     |
| **Void EFT            | <a href="#">9353</a>  |                     |                 | 03/06/2026             |                       | 0.00                  |                     |
| <b>Payable Number</b> | <b>Description</b>    | <b>Payable Date</b> | <b>Due Date</b> | <b>Discount Amount</b> | <b>Payable Amount</b> |                       |                     |
|                       |                       |                     |                 | 0.00                   | 0.00                  |                       |                     |
| **Void EFT            | <a href="#">9364</a>  |                     |                 | 03/06/2026             |                       | 0.00                  |                     |
| <b>Payable Number</b> | <b>Description</b>    | <b>Payable Date</b> | <b>Due Date</b> | <b>Discount Amount</b> | <b>Payable Amount</b> |                       |                     |
|                       |                       |                     |                 | 0.00                   | 0.00                  |                       |                     |
| **Void EFT            | <a href="#">9365</a>  |                     |                 | 03/06/2026             |                       | 0.00                  |                     |
| <b>Payable Number</b> | <b>Description</b>    | <b>Payable Date</b> | <b>Due Date</b> | <b>Discount Amount</b> | <b>Payable Amount</b> |                       |                     |
|                       |                       |                     |                 | 0.00                   | 0.00                  |                       |                     |
| **Void EFT            | <a href="#">9366</a>  |                     |                 | 03/06/2026             |                       | 0.00                  |                     |
| <b>Payable Number</b> | <b>Description</b>    | <b>Payable Date</b> | <b>Due Date</b> | <b>Discount Amount</b> | <b>Payable Amount</b> |                       |                     |
|                       |                       |                     |                 | 0.00                   | 0.00                  |                       |                     |
| **Void EFT            | <a href="#">9367</a>  |                     |                 | 03/06/2026             |                       | 0.00                  |                     |
| <b>Payable Number</b> | <b>Description</b>    | <b>Payable Date</b> | <b>Due Date</b> | <b>Discount Amount</b> | <b>Payable Amount</b> |                       |                     |
|                       |                       |                     |                 | 0.00                   | 0.00                  |                       |                     |

| Vendor Number          | Vendor Name               |                     |                 |                        |                       |                       | Total Vendor Amount |
|------------------------|---------------------------|---------------------|-----------------|------------------------|-----------------------|-----------------------|---------------------|
| <a href="#">038366</a> | 3D Homes Inc              |                     |                 |                        |                       |                       | 30,000.00           |
| <b>Payment Type</b>    | <b>Payment Number</b>     |                     |                 | <b>Payment Date</b>    |                       | <b>Payment Amount</b> |                     |
| EFT                    | <a href="#">9339</a>      |                     |                 | 03/06/2026             |                       | 30,000.00             |                     |
| <b>Payable Number</b>  | <b>Description</b>        | <b>Payable Date</b> | <b>Due Date</b> | <b>Discount Amount</b> | <b>Payable Amount</b> |                       |                     |
| <a href="#">1007</a>   | 401 North 10th Model Home | 02/24/2026          | 03/24/2026      | 0.00                   | 30,000.00             |                       |                     |

| Vendor Number          | Vendor Name                        |                     |                 |                        |                       |                       | Total Vendor Amount |
|------------------------|------------------------------------|---------------------|-----------------|------------------------|-----------------------|-----------------------|---------------------|
| <a href="#">035900</a> | Ane Mae's Coffee And Sandwich Shop |                     |                 |                        |                       |                       | 10.00               |
| <b>Payment Type</b>    | <b>Payment Number</b>              |                     |                 | <b>Payment Date</b>    |                       | <b>Payment Amount</b> |                     |
| EFT                    | <a href="#">9340</a>               |                     |                 | 03/06/2026             |                       | 10.00                 |                     |
| <b>Payable Number</b>  | <b>Description</b>                 | <b>Payable Date</b> | <b>Due Date</b> | <b>Discount Amount</b> | <b>Payable Amount</b> |                       |                     |
| <a href="#">13254</a>  | Coffee                             | 02/26/2026          | 03/28/2026      | 0.00                   | 10.00                 |                       |                     |

| Vendor Number          | Vendor Name           |                     |                 |                        |                       |                       | Total Vendor Amount |
|------------------------|-----------------------|---------------------|-----------------|------------------------|-----------------------|-----------------------|---------------------|
| <a href="#">038287</a> | Ashcraft Tire & Auto  |                     |                 |                        |                       |                       | 1,203.39            |
| <b>Payment Type</b>    | <b>Payment Number</b> |                     |                 | <b>Payment Date</b>    |                       | <b>Payment Amount</b> |                     |
| EFT                    | <a href="#">9341</a>  |                     |                 | 03/06/2026             |                       | 1,203.39              |                     |
| <b>Payable Number</b>  | <b>Description</b>    | <b>Payable Date</b> | <b>Due Date</b> | <b>Discount Amount</b> | <b>Payable Amount</b> |                       |                     |
| <a href="#">051863</a> | 440 Tire              | 02/23/2026          | 03/25/2026      | 0.00                   | 210.62                |                       |                     |
| <a href="#">051923</a> | Battery               | 02/25/2026          | 03/27/2026      | 0.00                   | 195.65                |                       |                     |
| <a href="#">051976</a> | 2018 Silverado        | 03/03/2026          | 04/02/2026      | 0.00                   | 797.12                |                       |                     |

| Vendor Number                         | Vendor Name                        |                     |                 |                        |                       |                       | Total Vendor Amount |
|---------------------------------------|------------------------------------|---------------------|-----------------|------------------------|-----------------------|-----------------------|---------------------|
| <a href="#">034736</a>                | AT&T Mobility                      |                     |                 |                        |                       |                       | 641.89              |
| <b>Payment Type</b>                   | <b>Payment Number</b>              |                     |                 | <b>Payment Date</b>    |                       | <b>Payment Amount</b> |                     |
| Check                                 | <a href="#">80829</a>              |                     |                 | 03/06/2026             |                       | 641.89                |                     |
| <b>Payable Number</b>                 | <b>Description</b>                 | <b>Payable Date</b> | <b>Due Date</b> | <b>Discount Amount</b> | <b>Payable Amount</b> |                       |                     |
| <a href="#">287348209881X02272026</a> | Acct# 287348209881                 | 02/19/2026          | 03/21/2026      | 0.00                   | 99.46                 |                       |                     |
| <a href="#">287348366225X02272026</a> | Acct #287348366225 - Memorial Hall | 02/19/2026          | 03/21/2026      | 0.00                   | 542.43                |                       |                     |

**Payment Register**

**APPKT01838 - 3/6/2026 AP**

| Vendor Number                   | Vendor Name                       |                     |                 |                        |                       | Total Vendor Amount        |
|---------------------------------|-----------------------------------|---------------------|-----------------|------------------------|-----------------------|----------------------------|
| <a href="#">037126</a>          | Autozone, Inc                     |                     |                 |                        |                       | 153.09                     |
| <b>Payment Type</b>             | <b>Payment Number</b>             |                     |                 | <b>Payment Date</b>    | <b>Payment Amount</b> |                            |
| Check                           | <a href="#">80830</a>             |                     |                 | 03/06/2026             | 153.09                |                            |
| <b>Payable Number</b>           | <b>Description</b>                | <b>Payable Date</b> | <b>Due Date</b> | <b>Discount Amount</b> | <b>Payable Amount</b> |                            |
| <a href="#">01605665544</a>     | Battery                           | 03/02/2026          | 04/01/2026      | 0.00                   | 175.09                |                            |
| <a href="#">01605665545</a>     | Battery core refund               | 03/02/2026          | 04/01/2026      | 0.00                   | -22.00                |                            |
| <b>Vendor Number</b>            | <b>Vendor Name</b>                |                     |                 |                        |                       | <b>Total Vendor Amount</b> |
| <a href="#">032299</a>          | Barta Animal Hospital             |                     |                 |                        |                       | 1,758.50                   |
| <b>Payment Type</b>             | <b>Payment Number</b>             |                     |                 | <b>Payment Date</b>    | <b>Payment Amount</b> |                            |
| Check                           | <a href="#">80831</a>             |                     |                 | 03/06/2026             | 1,758.50              |                            |
| <b>Payable Number</b>           | <b>Description</b>                | <b>Payable Date</b> | <b>Due Date</b> | <b>Discount Amount</b> | <b>Payable Amount</b> |                            |
| <a href="#">3/2/26 Zoo Stmt</a> | Acct no 3645 - Feb. Services      | 03/02/2026          | 04/01/2026      | 0.00                   | 1,758.50              |                            |
| <b>Vendor Number</b>            | <b>Vendor Name</b>                |                     |                 |                        |                       | <b>Total Vendor Amount</b> |
| <a href="#">037975</a>          | Benefit Technology Resources, LLC |                     |                 |                        |                       | 450.00                     |
| <b>Payment Type</b>             | <b>Payment Number</b>             |                     |                 | <b>Payment Date</b>    | <b>Payment Amount</b> |                            |
| EFT                             | <a href="#">9342</a>              |                     |                 | 03/06/2026             | 450.00                |                            |
| <b>Payable Number</b>           | <b>Description</b>                | <b>Payable Date</b> | <b>Due Date</b> | <b>Discount Amount</b> | <b>Payable Amount</b> |                            |
| <a href="#">36727</a>           | 2025 Renewal & Enrollment Fee     | 12/13/2024          | 01/12/2025      | 0.00                   | 450.00                |                            |
| <b>Vendor Number</b>            | <b>Vendor Name</b>                |                     |                 |                        |                       | <b>Total Vendor Amount</b> |
| <a href="#">037601</a>          | Butler & Associates, P.A.         |                     |                 |                        |                       | 322.00                     |
| <b>Payment Type</b>             | <b>Payment Number</b>             |                     |                 | <b>Payment Date</b>    | <b>Payment Amount</b> |                            |
| EFT                             | <a href="#">9343</a>              |                     |                 | 03/06/2026             | 322.00                |                            |
| <b>Payable Number</b>           | <b>Description</b>                | <b>Payable Date</b> | <b>Due Date</b> | <b>Discount Amount</b> | <b>Payable Amount</b> |                            |
| <a href="#">183610</a>          | Ambulance Fees                    | 02/26/2026          | 03/28/2026      | 0.00                   | 322.00                |                            |
| <b>Vendor Number</b>            | <b>Vendor Name</b>                |                     |                 |                        |                       | <b>Total Vendor Amount</b> |
| <a href="#">033027</a>          | Cintas Corporation                |                     |                 |                        |                       | 254.67                     |
| <b>Payment Type</b>             | <b>Payment Number</b>             |                     |                 | <b>Payment Date</b>    | <b>Payment Amount</b> |                            |
| EFT                             | <a href="#">9344</a>              |                     |                 | 03/06/2026             | 254.67                |                            |
| <b>Payable Number</b>           | <b>Description</b>                | <b>Payable Date</b> | <b>Due Date</b> | <b>Discount Amount</b> | <b>Payable Amount</b> |                            |
| <a href="#">5319897008</a>      | Street First Aid                  | 02/23/2026          | 03/25/2026      | 0.00                   | 254.67                |                            |
| <b>Vendor Number</b>            | <b>Vendor Name</b>                |                     |                 |                        |                       | <b>Total Vendor Amount</b> |
| <a href="#">036561</a>          | Civicplus, LLC                    |                     |                 |                        |                       | 6,504.34                   |
| <b>Payment Type</b>             | <b>Payment Number</b>             |                     |                 | <b>Payment Date</b>    | <b>Payment Amount</b> |                            |
| EFT                             | <a href="#">9345</a>              |                     |                 | 03/06/2026             | 6,504.34              |                            |
| <b>Payable Number</b>           | <b>Description</b>                | <b>Payable Date</b> | <b>Due Date</b> | <b>Discount Amount</b> | <b>Payable Amount</b> |                            |
| <a href="#">361803</a>          | Municode binders                  | 01/31/2026          | 03/02/2026      | 0.00                   | 154.85                |                            |
| <a href="#">364905</a>          | Virtual Webmaster                 | 02/28/2026          | 03/30/2026      | 0.00                   | 6,349.49              |                            |
| <b>Vendor Number</b>            | <b>Vendor Name</b>                |                     |                 |                        |                       | <b>Total Vendor Amount</b> |
| <a href="#">033671</a>          | Coffeyville Feed & Farm Supply    |                     |                 |                        |                       | 2,321.50                   |
| <b>Payment Type</b>             | <b>Payment Number</b>             |                     |                 | <b>Payment Date</b>    | <b>Payment Amount</b> |                            |
| EFT                             | <a href="#">9346</a>              |                     |                 | 03/06/2026             | 2,321.50              |                            |
| <b>Payable Number</b>           | <b>Description</b>                | <b>Payable Date</b> | <b>Due Date</b> | <b>Discount Amount</b> | <b>Payable Amount</b> |                            |
| <a href="#">953615</a>          | diets                             | 03/04/2026          | 04/03/2026      | 0.00                   | 2,321.50              |                            |
| <b>Vendor Number</b>            | <b>Vendor Name</b>                |                     |                 |                        |                       | <b>Total Vendor Amount</b> |
| <a href="#">038082</a>          | CPI Financing LLC                 |                     |                 |                        |                       | 469.74                     |
| <b>Payment Type</b>             | <b>Payment Number</b>             |                     |                 | <b>Payment Date</b>    | <b>Payment Amount</b> |                            |
| EFT                             | <a href="#">9347</a>              |                     |                 | 03/06/2026             | 469.74                |                            |
| <b>Payable Number</b>           | <b>Description</b>                | <b>Payable Date</b> | <b>Due Date</b> | <b>Discount Amount</b> | <b>Payable Amount</b> |                            |
| <a href="#">CPIF30073</a>       | Printing                          | 03/06/2026          | 04/05/2026      | 0.00                   | 469.74                |                            |

**Payment Register**

**APPKT01838 - 3/6/2026 AP**

|  |   |                     |                 |                                      |                                 |
|--|---|---------------------|-----------------|--------------------------------------|---------------------------------|
| <b>Vendor Number</b><br><a href="#">032078</a> | <b>Vendor Name</b><br>CPR Pest Management, Inc. |                     |                 | <b>Total Vendor Amount</b><br>327.50 |                                 |
| <b>Payment Type</b><br>EFT                     | <b>Payment Number</b><br><a href="#">9348</a>   |                     |                 | <b>Payment Date</b><br>03/06/2026    | <b>Payment Amount</b><br>327.50 |
| <b>Payable Number</b>                          | <b>Description</b>                              | <b>Payable Date</b> | <b>Due Date</b> | <b>Discount Amount</b>               | <b>Payable Amount</b>           |
| <a href="#">50095</a>                          | City Hall Pest Control                          | 02/26/2026          | 03/28/2026      | 0.00                                 | 120.00                          |
| <a href="#">50096</a>                          | AWOL Pest Control                               | 02/26/2026          | 03/28/2026      | 0.00                                 | 27.50                           |
| <a href="#">50195</a>                          | Zoo monthly pest control                        | 02/27/2026          | 03/29/2026      | 0.00                                 | 90.00                           |
| <a href="#">50196</a>                          | Park monthly pest control                       | 02/27/2026          | 03/29/2026      | 0.00                                 | 90.00                           |

|  |   |                     |                 |   |                                    |
|--|---|---------------------|-----------------|---|------------------------------------|
| <b>Vendor Number</b><br><a href="#">035070</a> | <b>Vendor Name</b><br>D&F Services, LLC       |                     |                 | <b>Total Vendor Amount</b><br>40,572.00 |                                    |
| <b>Payment Type</b><br>EFT                     | <b>Payment Number</b><br><a href="#">9349</a> |                     |                 | <b>Payment Date</b><br>03/06/2026       | <b>Payment Amount</b><br>40,572.00 |
| <b>Payable Number</b>                          | <b>Description</b>                            | <b>Payable Date</b> | <b>Due Date</b> | <b>Discount Amount</b>                  | <b>Payable Amount</b>              |
| <a href="#">7623</a>                           | DFLOC   | 02/24/2026          | 03/26/2026      | 0.00                                    | 40,572.00                          |

|   |  |                     |                 |                                      |                                 |
|---|--|---------------------|-----------------|--------------------------------------|---------------------------------|
| <b>Vendor Number</b><br><a href="#">037979</a>      | <b>Vendor Name</b><br>Everyy                   |                     |                 | <b>Total Vendor Amount</b><br>132.06 |                                 |
| <b>Payment Type</b><br>Check                        | <b>Payment Number</b><br><a href="#">80832</a> |                     |                 | <b>Payment Date</b><br>03/06/2026    | <b>Payment Amount</b><br>132.06 |
| <b>Payable Number</b>                               | <b>Description</b>                             | <b>Payable Date</b> | <b>Due Date</b> | <b>Discount Amount</b>               | <b>Payable Amount</b>           |
| <a href="#">9829042450</a> <a href="#">Mar 2026</a> | Acct 9829042450 - 4233 S 10th - Ballpark       | 02/25/2026          | 02/25/2026      | 0.00                                 | 103.24                          |
| <a href="#">INV0005077</a>                          | 0530958500 - 122 West Locust                   | 02/23/2026          | 02/23/2026      | 0.00                                 | 28.82                           |

|  |   |                     |                 |   |                                    |
|--|---|---------------------|-----------------|---|------------------------------------|
| <b>Vendor Number</b><br><a href="#">035115</a> | <b>Vendor Name</b><br>Express Services, Inc.  |                     |                 | <b>Total Vendor Amount</b><br>57,565.91 |                                    |
| <b>Payment Type</b><br>EFT                     | <b>Payment Number</b><br><a href="#">9350</a> |                     |                 | <b>Payment Date</b><br>03/06/2026       | <b>Payment Amount</b><br>57,565.91 |
| <b>Payable Number</b>                          | <b>Description</b>                            | <b>Payable Date</b> | <b>Due Date</b> | <b>Discount Amount</b>                  | <b>Payable Amount</b>              |
| <a href="#">33468787</a>                       | Express Employment                            | 02/04/2026          | 03/06/2026      | 0.00                                    | 9,993.82                           |
| <a href="#">33499189</a>                       | Express Employment                            | 02/11/2026          | 03/13/2026      | 0.00                                    | 13,102.22                          |
| <a href="#">33526269</a>                       | Express Employment                            | 02/17/2026          | 03/19/2026      | 0.00                                    | 11,604.61                          |
| <a href="#">33557579</a>                       | Express Employment                            | 02/25/2026          | 03/27/2026      | 0.00                                    | 10,870.69                          |
| <a href="#">33581884</a>                       | Express Employment                            | 03/04/2026          | 04/03/2026      | 0.00                                    | 11,994.57                          |

|  |   |                     |                 |  |                                   |
|--|---|---------------------|-----------------|--|-----------------------------------|
| <b>Vendor Number</b><br><a href="#">037139</a> | <b>Vendor Name</b><br>Fleet Fuels, LLC        |                     |                 | <b>Total Vendor Amount</b><br>2,479.74 |                                   |
| <b>Payment Type</b><br>EFT                     | <b>Payment Number</b><br><a href="#">9352</a> |                     |                 | <b>Payment Date</b><br>03/06/2026      | <b>Payment Amount</b><br>2,479.74 |
| <b>Payable Number</b>                          | <b>Description</b>                            | <b>Payable Date</b> | <b>Due Date</b> | <b>Discount Amount</b>                 | <b>Payable Amount</b>             |
| <a href="#">CFSI-48436</a>                     | Animal Control Fuel                           | 03/01/2026          | 03/31/2026      | 0.00                                   | 50.54                             |
| <a href="#">CFSI-48437</a>                     | Fire/EMS Fuel                                 | 03/01/2026          | 03/31/2026      | 0.00                                   | 591.60                            |
| <a href="#">CFSI-48439</a>                     | Park Dept. Fuel                               | 03/01/2026          | 03/31/2026      | 0.00                                   | 56.78                             |
| <a href="#">CFSI-48440</a>                     | Police Fuel                                   | 03/01/2026          | 03/31/2026      | 0.00                                   | 383.95                            |
| <a href="#">CFSI-48441</a>                     | Public Safety Director Fuel                   | 03/01/2026          | 03/31/2026      | 0.00                                   | 28.19                             |
| <a href="#">CFSI-48442</a>                     | Sewer Collection Fuel                         | 03/01/2026          | 03/31/2026      | 0.00                                   | 227.08                            |
| <a href="#">CFSI-48443</a>                     | Street Fuel                                   | 03/01/2026          | 03/31/2026      | 0.00                                   | 242.48                            |
| <a href="#">CFSI-48444</a>                     | City Van                                      | 03/01/2026          | 03/31/2026      | 0.00                                   | 45.07                             |
| <a href="#">CFSI-48445</a>                     | Water Distribution Fuel                       | 03/01/2026          | 03/31/2026      | 0.00                                   | 211.34                            |
| <a href="#">CFSI-48446</a>                     | Sanitation Fuel                               | 03/01/2026          | 03/31/2026      | 0.00                                   | 642.71                            |

|  |  |                     |                 |  |                                   |
|--|--|---------------------|-----------------|--|-----------------------------------|
| <b>Vendor Number</b><br><a href="#">037986</a> | <b>Vendor Name</b><br>Gold Mechanical, Inc.    |                     |                 | <b>Total Vendor Amount</b><br>1,807.64 |                                   |
| <b>Payment Type</b><br>Check                   | <b>Payment Number</b><br><a href="#">80833</a> |                     |                 | <b>Payment Date</b><br>03/06/2026      | <b>Payment Amount</b><br>1,807.64 |
| <b>Payable Number</b>                          | <b>Description</b>                             | <b>Payable Date</b> | <b>Due Date</b> | <b>Discount Amount</b>                 | <b>Payable Amount</b>             |
| <a href="#">2252189</a>                        | Boiler Repair                                  | 09/02/2025          | 09/02/2025      | 0.00                                   | 1,807.64                          |

**Payment Register**

**APPKT01838 - 3/6/2026 AP**

| Vendor Number                  | Vendor Name                     |                     |                 |                        |                       | Total Vendor Amount        |
|--------------------------------|---------------------------------|---------------------|-----------------|------------------------|-----------------------|----------------------------|
| <a href="#">009330</a>         | Grainger                        |                     |                 |                        |                       | 8.88                       |
| <b>Payment Type</b>            | <b>Payment Number</b>           |                     |                 | <b>Payment Date</b>    | <b>Payment Amount</b> |                            |
| EFT                            | <a href="#">9354</a>            |                     |                 | 03/06/2026             | 8.88                  |                            |
| <b>Payable Number</b>          | <b>Description</b>              | <b>Payable Date</b> | <b>Due Date</b> | <b>Discount Amount</b> | <b>Payable Amount</b> |                            |
| <a href="#">9819099483</a>     | Gasket                          | 02/24/2026          | 03/26/2026      | 0.00                   | 8.88                  |                            |
| <b>Vendor Number</b>           | <b>Vendor Name</b>              |                     |                 |                        |                       | <b>Total Vendor Amount</b> |
| <a href="#">008200</a>         | Harry Bass Attorney             |                     |                 |                        |                       | 1,200.00                   |
| <b>Payment Type</b>            | <b>Payment Number</b>           |                     |                 | <b>Payment Date</b>    | <b>Payment Amount</b> |                            |
| Check                          | <a href="#">80834</a>           |                     |                 | 03/06/2026             | 1,200.00              |                            |
| <b>Payable Number</b>          | <b>Description</b>              | <b>Payable Date</b> | <b>Due Date</b> | <b>Discount Amount</b> | <b>Payable Amount</b> |                            |
| <a href="#">2/26/2026 Stmt</a> | Court Appointment Attorney Fees | 02/26/2026          | 03/28/2026      | 0.00                   | 1,200.00              |                            |
| <b>Vendor Number</b>           | <b>Vendor Name</b>              |                     |                 |                        |                       | <b>Total Vendor Amount</b> |
| <a href="#">010440</a>         | Hugo's Industrial Supply        |                     |                 |                        |                       | 1,574.38                   |
| <b>Payment Type</b>            | <b>Payment Number</b>           |                     |                 | <b>Payment Date</b>    | <b>Payment Amount</b> |                            |
| EFT                            | <a href="#">9355</a>            |                     |                 | 03/06/2026             | 1,574.38              |                            |
| <b>Payable Number</b>          | <b>Description</b>              | <b>Payable Date</b> | <b>Due Date</b> | <b>Discount Amount</b> | <b>Payable Amount</b> |                            |
| <a href="#">347354</a>         | Trash bags                      | 01/22/2026          | 02/21/2026      | 0.00                   | 75.86                 |                            |
| <a href="#">347484</a>         | Ice Melt                        | 01/23/2026          | 02/22/2026      | 0.00                   | 76.10                 |                            |
| <a href="#">347533</a>         | Cleaning Supplies               | 01/26/2026          | 02/25/2026      | 0.00                   | 401.21                |                            |
| <a href="#">348894</a>         | Paper Towels and TP             | 02/25/2026          | 03/27/2026      | 0.00                   | 144.96                |                            |
| <a href="#">348972</a>         | Kwik sort                       | 02/27/2026          | 03/29/2026      | 0.00                   | 5.51                  |                            |
| <a href="#">349076</a>         | Toner & tape                    | 03/03/2026          | 04/02/2026      | 0.00                   | 240.22                |                            |
| <a href="#">349122</a>         | Toner                           | 03/04/2026          | 04/03/2026      | 0.00                   | 630.52                |                            |
| <b>Vendor Number</b>           | <b>Vendor Name</b>              |                     |                 |                        |                       | <b>Total Vendor Amount</b> |
| <a href="#">037732</a>         | IMA Financial Group, Inc.       |                     |                 |                        |                       | 5,000.00                   |
| <b>Payment Type</b>            | <b>Payment Number</b>           |                     |                 | <b>Payment Date</b>    | <b>Payment Amount</b> |                            |
| EFT                            | <a href="#">9356</a>            |                     |                 | 03/06/2026             | 5,000.00              |                            |
| <b>Payable Number</b>          | <b>Description</b>              | <b>Payable Date</b> | <b>Due Date</b> | <b>Discount Amount</b> | <b>Payable Amount</b> |                            |
| <a href="#">539446</a>         | Installment 3 of 4 and 4 of 4   | 02/26/2026          | 03/28/2026      | 0.00                   | 5,000.00              |                            |
| <b>Vendor Number</b>           | <b>Vendor Name</b>              |                     |                 |                        |                       | <b>Total Vendor Amount</b> |
| <a href="#">011240</a>         | Independence Overhead Door, Inc |                     |                 |                        |                       | 180.00                     |
| <b>Payment Type</b>            | <b>Payment Number</b>           |                     |                 | <b>Payment Date</b>    | <b>Payment Amount</b> |                            |
| Check                          | <a href="#">80835</a>           |                     |                 | 03/06/2026             | 180.00                |                            |
| <b>Payable Number</b>          | <b>Description</b>              | <b>Payable Date</b> | <b>Due Date</b> | <b>Discount Amount</b> | <b>Payable Amount</b> |                            |
| <a href="#">49981</a>          | Garage door service/repair      | 02/18/2026          | 03/20/2026      | 0.00                   | 180.00                |                            |
| <b>Vendor Number</b>           | <b>Vendor Name</b>              |                     |                 |                        |                       | <b>Total Vendor Amount</b> |
| <a href="#">011290</a>         | Independence Ready Mix          |                     |                 |                        |                       | 2,338.20                   |
| <b>Payment Type</b>            | <b>Payment Number</b>           |                     |                 | <b>Payment Date</b>    | <b>Payment Amount</b> |                            |
| EFT                            | <a href="#">9357</a>            |                     |                 | 03/06/2026             | 2,338.20              |                            |
| <b>Payable Number</b>          | <b>Description</b>              | <b>Payable Date</b> | <b>Due Date</b> | <b>Discount Amount</b> | <b>Payable Amount</b> |                            |
| <a href="#">48775-2</a>        | Concrete floor                  | 09/23/2025          | 10/23/2025      | 0.00                   | 722.00                |                            |
| <a href="#">48776-2</a>        | Concrete floor                  | 03/23/2025          | 04/22/2025      | 0.00                   | 720.00                |                            |
| <a href="#">49835</a>          | Concrete floor                  | 02/20/2026          | 03/22/2026      | 0.00                   | 810.00                |                            |
| <a href="#">FC 1446</a>        | Finance Charge                  | 11/30/2025          | 12/30/2025      | 0.00                   | 34.83                 |                            |
| <a href="#">FC 1474</a>        | Finance Charge                  | 01/31/2026          | 03/02/2026      | 0.00                   | 35.39                 |                            |
| <a href="#">FC 1489</a>        | Finance Charge                  | 02/28/2026          | 03/30/2026      | 0.00                   | 15.98                 |                            |
| <b>Vendor Number</b>           | <b>Vendor Name</b>              |                     |                 |                        |                       | <b>Total Vendor Amount</b> |
| <a href="#">032474</a>         | Kansas One-Call System, Inc.    |                     |                 |                        |                       | 146.30                     |
| <b>Payment Type</b>            | <b>Payment Number</b>           |                     |                 | <b>Payment Date</b>    | <b>Payment Amount</b> |                            |
| EFT                            | <a href="#">9358</a>            |                     |                 | 03/06/2026             | 146.30                |                            |
| <b>Payable Number</b>          | <b>Description</b>              | <b>Payable Date</b> | <b>Due Date</b> | <b>Discount Amount</b> | <b>Payable Amount</b> |                            |
| <a href="#">6020321</a>        | Locates                         | 02/28/2026          | 03/30/2026      | 0.00                   | 146.30                |                            |

**Payment Register**

**APPKT01838 - 3/6/2026 AP**

| Vendor Number              | Vendor Name  |                     |                 |                        |                       | Total Vendor Amount   |
|----------------------------|--|---------------------|-----------------|------------------------|-----------------------|-----------------------|
| <a href="#">013351</a>     | KC 24 Hour Truck Repair                            |                     |                 |                        |                       | 1,223.09              |
| <b>Payment Type</b>        | <b>Payment Number</b>                              |                     |                 | <b>Payment Date</b>    |                       | <b>Payment Amount</b> |
| EFT                        | <a href="#">9359</a>                               |                     |                 | 03/06/2026             |                       | 1,223.09              |
| <b>Payable Number</b>      | <b>Description</b>                                 | <b>Payable Date</b> | <b>Due Date</b> | <b>Discount Amount</b> | <b>Payable Amount</b> |                       |
| <a href="#">5476</a>       | Tranker 1 Repair and Service                       | 02/24/2026          | 03/26/2026      | 0.00                   | 813.09                |                       |
| <a href="#">5477</a>       | Medic 5 Coolant hose repair, charging issue repair | 02/24/2026          | 03/26/2026      | 0.00                   | 410.00                |                       |
| <a href="#">035962</a>     | KU Public Management Center                        |                     |                 |                        |                       | 3,900.00              |
| <b>Payment Type</b>        | <b>Payment Number</b>                              |                     |                 | <b>Payment Date</b>    |                       | <b>Payment Amount</b> |
| Check                      | <a href="#">80836</a>                              |                     |                 | 03/06/2026             |                       | 3,900.00              |
| <b>Payable Number</b>      | <b>Description</b>                                 | <b>Payable Date</b> | <b>Due Date</b> | <b>Discount Amount</b> | <b>Payable Amount</b> |                       |
| <a href="#">3ABB49C1</a>   | Scott training                                     | 08/06/2025          | 09/05/2025      | 0.00                   | 3,900.00              |                       |
| <a href="#">014250</a>     | Lee's Cooling & Heating                            |                     |                 |                        |                       | 2,800.00              |
| <b>Payment Type</b>        | <b>Payment Number</b>                              |                     |                 | <b>Payment Date</b>    |                       | <b>Payment Amount</b> |
| EFT                        | <a href="#">9360</a>                               |                     |                 | 03/06/2026             |                       | 2,800.00              |
| <b>Payable Number</b>      | <b>Description</b>                                 | <b>Payable Date</b> | <b>Due Date</b> | <b>Discount Amount</b> | <b>Payable Amount</b> |                       |
| <a href="#">54359948</a>   | Unit Inspection                                    | 02/18/2026          | 03/20/2026      | 0.00                   | 2,800.00              |                       |
| <a href="#">036790</a>     | Life-Assist, Inc                                   |                     |                 |                        |                       | 4,396.85              |
| <b>Payment Type</b>        | <b>Payment Number</b>                              |                     |                 | <b>Payment Date</b>    |                       | <b>Payment Amount</b> |
| EFT                        | <a href="#">9361</a>                               |                     |                 | 03/06/2026             |                       | 4,396.85              |
| <b>Payable Number</b>      | <b>Description</b>                                 | <b>Payable Date</b> | <b>Due Date</b> | <b>Discount Amount</b> | <b>Payable Amount</b> |                       |
| <a href="#">2042753</a>    | Coban, Pillow Cases, Cot Sheets, Nasal Cannulas    | 01/05/2026          | 02/04/2026      | 0.00                   | 499.73                |                       |
| <a href="#">2050495</a>    | BVM's, IV Caths, Tourniquets, Pillow Cases         | 01/16/2026          | 02/15/2026      | 0.00                   | 319.14                |                       |
| <a href="#">2050780</a>    | I-Gel Airways Pediatric-Adult                      | 01/16/2026          | 02/15/2026      | 0.00                   | 1,067.85              |                       |
| <a href="#">2050983</a>    | Infant I-Gel Airways                               | 01/20/2026          | 02/19/2026      | 0.00                   | 75.85                 |                       |
| <a href="#">2052852</a>    | I-Gel Rescue Pack for Adults                       | 01/21/2026          | 02/20/2026      | 0.00                   | 168.06                |                       |
| <a href="#">2053197</a>    | Cot Sheets, Pediatric C-Collars, IV Ext. Sets      | 01/21/2026          | 02/20/2026      | 0.00                   | 452.80                |                       |
| <a href="#">2056349</a>    | Pediatric Measuring/Dose Tape                      | 02/05/2026          | 03/07/2026      | 0.00                   | 50.85                 |                       |
| <a href="#">2059350</a>    | Buretrol IV Sets for Pediatrics                    | 02/02/2026          | 03/04/2026      | 0.00                   | 165.40                |                       |
| <a href="#">2062076</a>    | Zoll CPR Stat Pads                                 | 02/05/2026          | 03/07/2026      | 0.00                   | 837.04                |                       |
| <a href="#">2069804</a>    | Adult BP Cuffs for the Zoll Monitor                | 02/18/2026          | 03/20/2026      | 0.00                   | 125.84                |                       |
| <a href="#">2070672</a>    | IV Caths, ET Tube, Splints, IV Ext. Sets, Veni Gua | 02/20/2026          | 03/22/2026      | 0.00                   | 313.14                |                       |
| <a href="#">2075402</a>    | Newborn OB Kids, Pediatric Electrodes              | 02/27/2026          | 03/29/2026      | 0.00                   | 321.15                |                       |
| <a href="#">037950</a>     | Medical Air Services Association                   |                     |                 |                        |                       | 688.00                |
| <b>Payment Type</b>        | <b>Payment Number</b>                              |                     |                 | <b>Payment Date</b>    |                       | <b>Payment Amount</b> |
| EFT                        | <a href="#">9362</a>                               |                     |                 | 03/06/2026             |                       | 688.00                |
| <b>Payable Number</b>      | <b>Description</b>                                 | <b>Payable Date</b> | <b>Due Date</b> | <b>Discount Amount</b> | <b>Payable Amount</b> |                       |
| <a href="#">2280848</a>    | B2BNETCIK - Medical Air Services Premium           | 02/01/2026          | 03/03/2026      | 0.00                   | 688.00                |                       |
| <a href="#">037915</a>     | Metropolitan Life Insurance Company                |                     |                 |                        |                       | 5,081.68              |
| <b>Payment Type</b>        | <b>Payment Number</b>                              |                     |                 | <b>Payment Date</b>    |                       | <b>Payment Amount</b> |
| EFT                        | <a href="#">9363</a>                               |                     |                 | 03/06/2026             |                       | 5,081.68              |
| <b>Payable Number</b>      | <b>Description</b>                                 | <b>Payable Date</b> | <b>Due Date</b> | <b>Discount Amount</b> | <b>Payable Amount</b> |                       |
| <a href="#">INV0004850</a> | 5391110 - Accident Insurance                       | 02/13/2026          | 02/13/2026      | 0.00                   | 356.98                |                       |
| <a href="#">INV0004851</a> | 5391110 - Critical Illness Premium                 | 02/13/2026          | 02/28/2026      | 0.00                   | 291.99                |                       |
| <a href="#">INV0004856</a> | 5391110 - Basic Group AD&D Premium                 | 02/13/2026          | 02/13/2026      | 0.00                   | 118.24                |                       |
| <a href="#">INV0004857</a> | 5391110 - Basic Group Life Insurance Premium       | 02/13/2026          | 02/13/2026      | 0.00                   | 964.61                |                       |
| <a href="#">INV0004859</a> | 5391110 - Hospital Indemnity Premium               | 02/13/2026          | 02/28/2026      | 0.00                   | 100.88                |                       |
| <a href="#">INV0004869</a> | 5391110 - Short Term Disability Premium            | 02/13/2026          | 02/28/2026      | 0.00                   | 687.92                |                       |
| <a href="#">INV0004871</a> | 5391110 - Voluntary AD&D Premium                   | 02/13/2026          | 02/28/2026      | 0.00                   | 47.10                 |                       |
| <a href="#">INV0004872</a> | 5391110 - Voluntary Life Ins Premium               | 02/13/2026          | 02/28/2026      | 0.00                   | 535.53                |                       |
| <a href="#">INV0005025</a> | 5391110 - Accident Insurance                       | 02/27/2026          | 02/27/2026      | 0.00                   | 356.89                |                       |
| <a href="#">INV0005026</a> | 5391110 - Critical Illness Premium                 | 02/27/2026          | 02/28/2026      | 0.00                   | 291.96                |                       |

**Payment Register**

**APPKT01838 - 3/6/2026 AP**

|                            |  |                     |                       |                            |                       |
|----------------------------|--|---------------------|-----------------------|----------------------------|-----------------------|
| <a href="#">INV0005031</a> | 5391110 - Basic Group AD&D Premium           | 02/27/2026          | 02/27/2026            | 0.00                       | 1.04                  |
| <a href="#">INV0005032</a> | 5391110 - Basic Group Life Insurance Premium | 02/27/2026          | 02/27/2026            | 0.00                       | 11.49                 |
| <a href="#">INV0005034</a> | 5391110 - Hospital Indemnity Premium         | 02/27/2026          | 02/28/2026            | 0.00                       | 117.05                |
| <a href="#">INV0005045</a> | 5391110 - Short Term Disability Premium      | 02/27/2026          | 02/28/2026            | 0.00                       | 617.63                |
| <a href="#">INV0005047</a> | 5391110 - Voluntary AD&D Premium             | 02/27/2026          | 02/28/2026            | 0.00                       | 46.90                 |
| <a href="#">INV0005048</a> | 5391110 - Voluntary Life Ins Premium         | 02/27/2026          | 02/28/2026            | 0.00                       | 535.47                |
| <b>Vendor Number</b>       | <b>Vendor Name</b>                           |                     |                       | <b>Total Vendor Amount</b> |                       |
| <a href="#">038137</a>     | Michael P. O'Connor                          |                     |                       | 442.88                     |                       |
| <b>Payment Type</b>        | <b>Payment Number</b>                        | <b>Payment Date</b> | <b>Payment Amount</b> |                            |                       |
| Check                      | <a href="#">80837</a>                        | 03/06/2026          | 442.88                |                            |                       |
| <b>Payable Number</b>      | <b>Description</b>                           | <b>Payable Date</b> | <b>Due Date</b>       | <b>Discount Amount</b>     | <b>Payable Amount</b> |
| <a href="#">INV0005080</a> | Firefighter 2 Class Instruction              | 02/22/2026          | 02/22/2026            | 0.00                       | 442.88                |
| <b>Vendor Number</b>       | <b>Vendor Name</b>                           |                     |                       | <b>Total Vendor Amount</b> |                       |
| <a href="#">034873</a>     | Montgomery County Chronicle                  |                     |                       | 132.00                     |                       |
| <b>Payment Type</b>        | <b>Payment Number</b>                        | <b>Payment Date</b> | <b>Payment Amount</b> |                            |                       |
| Check                      | <a href="#">80838</a>                        | 03/06/2026          | 132.00                |                            |                       |
| <b>Payable Number</b>      | <b>Description</b>                           | <b>Payable Date</b> | <b>Due Date</b>       | <b>Discount Amount</b>     | <b>Payable Amount</b> |
| <a href="#">INV0005078</a> | Ad - Chronicle                               | 02/26/2026          | 03/28/2026            | 0.00                       | 132.00                |
| <b>Vendor Number</b>       | <b>Vendor Name</b>                           |                     |                       | <b>Total Vendor Amount</b> |                       |
| <a href="#">036981</a>     | Montgomery County Rwd #2                     |                     |                       | 48.00                      |                       |
| <b>Payment Type</b>        | <b>Payment Number</b>                        | <b>Payment Date</b> | <b>Payment Amount</b> |                            |                       |
| EFT                        | <a href="#">9368</a>                         | 03/06/2026          | 48.00                 |                            |                       |
| <b>Payable Number</b>      | <b>Description</b>                           | <b>Payable Date</b> | <b>Due Date</b>       | <b>Discount Amount</b>     | <b>Payable Amount</b> |
| <a href="#">Feb 2026</a>   | Usage Meter Readings                         | 03/01/2026          | 03/31/2026            | 0.00                       | 48.00                 |
| <b>Vendor Number</b>       | <b>Vendor Name</b>                           |                     |                       | <b>Total Vendor Amount</b> |                       |
| <a href="#">036978</a>     | Municipal H2O                                |                     |                       | 4,200.00                   |                       |
| <b>Payment Type</b>        | <b>Payment Number</b>                        | <b>Payment Date</b> | <b>Payment Amount</b> |                            |                       |
| EFT                        | <a href="#">9369</a>                         | 03/06/2026          | 4,200.00              |                            |                       |
| <b>Payable Number</b>      | <b>Description</b>                           | <b>Payable Date</b> | <b>Due Date</b>       | <b>Discount Amount</b>     | <b>Payable Amount</b> |
| <a href="#">15068</a>      | Annual EPA RMP Compliance service fee        | 03/01/2026          | 03/31/2026            | 0.00                       | 4,200.00              |
| <b>Vendor Number</b>       | <b>Vendor Name</b>                           |                     |                       | <b>Total Vendor Amount</b> |                       |
| <a href="#">038359</a>     | National Sign Company LLC                    |                     |                       | 1,305.54                   |                       |
| <b>Payment Type</b>        | <b>Payment Number</b>                        | <b>Payment Date</b> | <b>Payment Amount</b> |                            |                       |
| EFT                        | <a href="#">9370</a>                         | 03/06/2026          | 1,305.54              |                            |                       |
| <b>Payable Number</b>      | <b>Description</b>                           | <b>Payable Date</b> | <b>Due Date</b>       | <b>Discount Amount</b>     | <b>Payable Amount</b> |
| <a href="#">IN0001036</a>  | Stop and custom street signs                 | 02/17/2026          | 02/17/2026            | 0.00                       | 1,305.54              |
| <b>Vendor Number</b>       | <b>Vendor Name</b>                           |                     |                       | <b>Total Vendor Amount</b> |                       |
| <a href="#">038207</a>     | Phils Construction                           |                     |                       | 1,200.00                   |                       |
| <b>Payment Type</b>        | <b>Payment Number</b>                        | <b>Payment Date</b> | <b>Payment Amount</b> |                            |                       |
| EFT                        | <a href="#">9371</a>                         | 03/06/2026          | 1,200.00              |                            |                       |
| <b>Payable Number</b>      | <b>Description</b>                           | <b>Payable Date</b> | <b>Due Date</b>       | <b>Discount Amount</b>     | <b>Payable Amount</b> |
| <a href="#">98</a>         | concrete floor                               | 03/04/2026          | 03/04/2026            | 0.00                       | 1,200.00              |
| <b>Vendor Number</b>       | <b>Vendor Name</b>                           |                     |                       | <b>Total Vendor Amount</b> |                       |
| <a href="#">036591</a>     | Premier Truck Group Of Tulsa                 |                     |                       | 6,713.56                   |                       |
| <b>Payment Type</b>        | <b>Payment Number</b>                        | <b>Payment Date</b> | <b>Payment Amount</b> |                            |                       |
| Check                      | <a href="#">80839</a>                        | 03/06/2026          | 6,713.56              |                            |                       |
| <b>Payable Number</b>      | <b>Description</b>                           | <b>Payable Date</b> | <b>Due Date</b>       | <b>Discount Amount</b>     | <b>Payable Amount</b> |
| <a href="#">12589069</a>   | 503 air tanks                                | 02/13/2026          | 03/15/2026            | 0.00                       | 6,713.56              |

**Payment Register**

**APPKT01838 - 3/6/2026 AP**

| Vendor Number                     | Vendor Name                               |                     |                 |                        |                       | Total Vendor Amount |
|-----------------------------------|---|---------------------|-----------------|------------------------|-----------------------|---------------------|
| <a href="#">033732</a>            | Quest Diagnostics                         |                     |                 |                        |                       | 237.60              |
| <b>Payment Type</b>               | <b>Payment Number</b>                     |                     |                 | <b>Payment Date</b>    | <b>Payment Amount</b> |                     |
| Check                             | <a href="#">80840</a>                     |                     |                 | 03/06/2026             | 237.60                |                     |
| <b>Payable Number</b>             | <b>Description</b>                        | <b>Payable Date</b> | <b>Due Date</b> | <b>Discount Amount</b> | <b>Payable Amount</b> |                     |
| <a href="#">9219617062</a>        | New Hires                                 | 02/24/2026          | 03/26/2026      | 0.00                   | 237.60                |                     |
| <a href="#">021300</a>            | Resource Recovery Div 4392                |                     |                 |                        |                       | 11,091.66           |
| <b>Payment Type</b>               | <b>Payment Number</b>                     |                     |                 | <b>Payment Date</b>    | <b>Payment Amount</b> |                     |
| EFT                               | <a href="#">9372</a>                      |                     |                 | 03/06/2026             | 11,091.66             |                     |
| <b>Payable Number</b>             | <b>Description</b>                        | <b>Payable Date</b> | <b>Due Date</b> | <b>Discount Amount</b> | <b>Payable Amount</b> |                     |
| <a href="#">4392-000009291</a>    | Landfill                                  | 02/28/2026          | 03/30/2026      | 0.00                   | 11,091.66             |                     |
| <a href="#">035797</a>            | Southeast Kansas Education Service Center |                     |                 |                        |                       | 633.48              |
| <b>Payment Type</b>               | <b>Payment Number</b>                     |                     |                 | <b>Payment Date</b>    | <b>Payment Amount</b> |                     |
| Check                             | <a href="#">80841</a>                     |                     |                 | 03/06/2026             | 633.48                |                     |
| <b>Payable Number</b>             | <b>Description</b>                        | <b>Payable Date</b> | <b>Due Date</b> | <b>Discount Amount</b> | <b>Payable Amount</b> |                     |
| <a href="#">0226144</a>           | Participation and Serv Fee                | 02/10/2026          | 03/12/2026      | 0.00                   | 633.48                |                     |
| <a href="#">034515</a>            | Tidy Whitie's Laundromat                  |                     |                 |                        |                       | 22.50               |
| <b>Payment Type</b>               | <b>Payment Number</b>                     |                     |                 | <b>Payment Date</b>    | <b>Payment Amount</b> |                     |
| EFT                               | <a href="#">9373</a>                      |                     |                 | 03/06/2026             | 22.50                 |                     |
| <b>Payable Number</b>             | <b>Description</b>                        | <b>Payable Date</b> | <b>Due Date</b> | <b>Discount Amount</b> | <b>Payable Amount</b> |                     |
| <a href="#">7011</a>              | Wash and Fold                             | 02/18/2026          | 03/20/2026      | 0.00                   | 22.50                 |                     |
| <a href="#">032956</a>            | TLC Nursery & Outdoor Living              |                     |                 |                        |                       | 1,054.00            |
| <b>Payment Type</b>               | <b>Payment Number</b>                     |                     |                 | <b>Payment Date</b>    | <b>Payment Amount</b> |                     |
| EFT                               | <a href="#">9374</a>                      |                     |                 | 03/06/2026             | 1,054.00              |                     |
| <b>Payable Number</b>             | <b>Description</b>                        | <b>Payable Date</b> | <b>Due Date</b> | <b>Discount Amount</b> | <b>Payable Amount</b> |                     |
| <a href="#">12201</a>             | Snow & Ice                                | 03/02/2026          | 04/01/2026      | 0.00                   | 491.00                |                     |
| <a href="#">12203</a>             | Snow & Ice removal                        | 03/02/2026          | 04/01/2026      | 0.00                   | 563.00                |                     |
| <a href="#">038037</a>            | Trident Partnerships LLC                  |                     |                 |                        |                       | 2,837.24            |
| <b>Payment Type</b>               | <b>Payment Number</b>                     |                     |                 | <b>Payment Date</b>    | <b>Payment Amount</b> |                     |
| EFT                               | <a href="#">9375</a>                      |                     |                 | 03/06/2026             | 2,837.24              |                     |
| <b>Payable Number</b>             | <b>Description</b>                        | <b>Payable Date</b> | <b>Due Date</b> | <b>Discount Amount</b> | <b>Payable Amount</b> |                     |
| <a href="#">Disbursement no 5</a> | Trident MIH Project - Downtown            | 02/23/2026          | 02/23/2026      | 0.00                   | 2,837.24              |                     |
| <a href="#">038182</a>            | Vogelsang USA, Ltd.                       |                     |                 |                        |                       | 58,070.65           |
| <b>Payment Type</b>               | <b>Payment Number</b>                     |                     |                 | <b>Payment Date</b>    | <b>Payment Amount</b> |                     |
| EFT                               | <a href="#">9376</a>                      |                     |                 | 03/06/2026             | 58,070.65             |                     |
| <b>Payable Number</b>             | <b>Description</b>                        | <b>Payable Date</b> | <b>Due Date</b> | <b>Discount Amount</b> | <b>Payable Amount</b> |                     |
| <a href="#">50021539</a>          | Sewage Grinder Pump                       | 09/30/2025          | 09/30/2025      | 0.00                   | 58,070.65             |                     |
| <a href="#">035913</a>            | Waters Hardware                           |                     |                 |                        |                       | 225.62              |
| <b>Payment Type</b>               | <b>Payment Number</b>                     |                     |                 | <b>Payment Date</b>    | <b>Payment Amount</b> |                     |
| EFT                               | <a href="#">9377</a>                      |                     |                 | 03/06/2026             | 225.62                |                     |
| <b>Payable Number</b>             | <b>Description</b>                        | <b>Payable Date</b> | <b>Due Date</b> | <b>Discount Amount</b> | <b>Payable Amount</b> |                     |
| <a href="#">7560/P</a>            | Cust no 72177 - Hose repair               | 12/09/2025          | 01/08/2026      | 0.00                   | 6.49                  |                     |
| <a href="#">807511</a>            | Cust no 72178 - Finance Charge            | 02/28/2026          | 03/30/2026      | 0.00                   | 0.50                  |                     |
| <a href="#">8468/P</a>            | Cust no 72177 - Tote                      | 02/20/2026          | 03/22/2026      | 0.00                   | 71.98                 |                     |
| <a href="#">8508/P</a>            | Cust no 72177 - Mortar Hoe                | 02/24/2026          | 03/26/2026      | 0.00                   | 41.99                 |                     |
| <a href="#">8542/P</a>            | Cust no 72177 - Cleaning supplies         | 02/26/2026          | 03/28/2026      | 0.00                   | 85.47                 |                     |
| <a href="#">8598/P</a>            | Cust no 72177 - Red rosin                 | 03/03/2026          | 04/02/2026      | 0.00                   | 21.99                 |                     |

**Payment Register**

**APPKT01838 - 3/6/2026 AP**

[B55352](#) Cust no 72182 - Finance Charge 10/28/2025 11/27/2025 0.00 -2.80

|                        |                      |  |  |                            |
|------------------------|----------------------|--|--|----------------------------|
| <b>Vendor Number</b>   | <b>Vendor Name</b>   |  |  | <b>Total Vendor Amount</b> |
| <a href="#">038154</a> | WCD Enterprises, LLC |  |  | 750.00                     |

|                     |                       |                     |                       |
|---------------------|-----------------------|---------------------|-----------------------|
| <b>Payment Type</b> | <b>Payment Number</b> | <b>Payment Date</b> | <b>Payment Amount</b> |
| Check               | <a href="#">80842</a> | 03/06/2026          | 750.00                |

|                        |                     |                     |                 |                        |                       |
|------------------------|---------------------|---------------------|-----------------|------------------------|-----------------------|
| <b>Payable Number</b>  | <b>Description</b>  | <b>Payable Date</b> | <b>Due Date</b> | <b>Discount Amount</b> | <b>Payable Amount</b> |
| <a href="#">435509</a> | Janitorial Services | 03/03/2026          | 04/02/2026      | 0.00                   | 750.00                |

|                        |                      |  |  |                            |
|------------------------|----------------------|--|--|----------------------------|
| <b>Vendor Number</b>   | <b>Vendor Name</b>   |  |  | <b>Total Vendor Amount</b> |
| <a href="#">034744</a> | Woods Lumber Company |  |  | 6,109.13                   |

|                     |                       |                     |                       |
|---------------------|-----------------------|---------------------|-----------------------|
| <b>Payment Type</b> | <b>Payment Number</b> | <b>Payment Date</b> | <b>Payment Amount</b> |
| EFT                 | <a href="#">9378</a>  | 03/06/2026          | 6,109.13              |

|                        |   |                     |                 |                        |                       |
|------------------------|---|---------------------|-----------------|------------------------|-----------------------|
| <b>Payable Number</b>  | <b>Description</b>                                | <b>Payable Date</b> | <b>Due Date</b> | <b>Discount Amount</b> | <b>Payable Amount</b> |
| <a href="#">616967</a> | Conc tools rental final contract                  | 09/23/2025          | 10/23/2025      | 0.00                   | 66.00                 |
| <a href="#">617310</a> | Auger driver, auger, hammer rental final contract | 09/25/2025          | 10/25/2025      | 0.00                   | 522.00                |
| <a href="#">617806</a> | Rental  | 09/30/2025          | 10/30/2025      | 0.00                   | 153.00                |
| <a href="#">617975</a> | Paint & tape                                      | 10/01/2025          | 10/31/2025      | 0.00                   | 135.48                |
| <a href="#">622337</a> | Tools   | 11/06/2025          | 12/06/2025      | 0.00                   | 25.48                 |
| <a href="#">623292</a> | Tractor tiller rental final contract              | 11/14/2025          | 12/14/2025      | 0.00                   | 105.00                |
| <a href="#">626130</a> | mini golf fence                                   | 12/11/2025          | 01/10/2026      | 0.00                   | 4,852.50              |
| <a href="#">633097</a> | Concrete  | 02/24/2026          | 03/26/2026      | 0.00                   | 48.51                 |
| <a href="#">633144</a> | Concrete mix                                      | 02/24/2026          | 03/26/2026      | 0.00                   | 43.12                 |
| <a href="#">633413</a> | Grout   | 02/26/2026          | 03/28/2026      | 0.00                   | 89.94                 |
| <a href="#">633871</a> | Concession stand repair                           | 03/03/2026          | 04/02/2026      | 0.00                   | 68.10                 |

|                        |                     |  |  |                            |
|------------------------|---------------------|--|--|----------------------------|
| <b>Vendor Number</b>   | <b>Vendor Name</b>  |  |  | <b>Total Vendor Amount</b> |
| <a href="#">037036</a> | Zinser Electric LLC |  |  | 8,400.00                   |

|                     |                       |                     |                       |
|---------------------|-----------------------|---------------------|-----------------------|
| <b>Payment Type</b> | <b>Payment Number</b> | <b>Payment Date</b> | <b>Payment Amount</b> |
| EFT                 | <a href="#">9379</a>  | 03/06/2026          | 8,400.00              |

|                       |                         |                     |                 |                        |                       |
|-----------------------|-------------------------|---------------------|-----------------|------------------------|-----------------------|
| <b>Payable Number</b> | <b>Description</b>      | <b>Payable Date</b> | <b>Due Date</b> | <b>Discount Amount</b> | <b>Payable Amount</b> |
| <a href="#">3168</a>  | Security Camera Project | 02/09/2026          | 03/11/2026      | 0.00                   | 8,400.00              |

**Payment Summary**

| Bank Code             | Type              | Payable<br>Count | Payment<br>Count | Discount    | Payment           |
|-----------------------|-------------------|------------------|------------------|-------------|-------------------|
| General               | Check             | 17               | 14               | 0.00        | 18,682.70         |
| General               | EFT               | 1                | 1                | 0.00        | 146.30            |
| General               | Voided **Void EFT | 0                | 1                | 0.00        | 0.00              |
| General               | EFT               | 5                | 1                | 0.00        | 57,565.91         |
| General               | Voided **Void EFT | 0                | 1                | 0.00        | 0.00              |
| General               | EFT               | 4                | 3                | 0.00        | 7,276.34          |
| General               | Voided **Void EFT | 0                | 1                | 0.00        | 0.00              |
| General               | EFT               | 2                | 2                | 0.00        | 60,907.89         |
| General               | Voided **Void EFT | 0                | 1                | 0.00        | 0.00              |
| General               | EFT               | 89               | 25               | 0.00        | 91,473.37         |
| General               | Voided **Void EFT | 0                | 1                | 0.00        | 0.00              |
| General               | EFT               | 8                | 3                | 0.00        | 42,932.70         |
| General               | Voided **Void EFT | 0                | 1                | 0.00        | 0.00              |
| <b>Packet Totals:</b> |                   | <b>126</b>       | <b>55</b>        | <b>0.00</b> | <b>278,985.21</b> |

### Cash Fund Summary

| Fund                  | Name        | Amount             |
|-----------------------|-------------|--------------------|
| 099                   | Pooled Cash | -278,985.21        |
| <b>Packet Totals:</b> |             | <b>-278,985.21</b> |



City of Independence

# Payment Register

APPKT01865 - 3/11/2026 AP  
01 - City of Independence

**Bank:** General - Community National Bank

| Vendor Number              | Vendor Name                       |              |                | Total Vendor Amount |                |
|----------------------------|-----------------------------------|--------------|----------------|---------------------|----------------|
| <a href="#">038095</a>     | Montgomery County Auto Tag Office |              |                | 47.25               |                |
| Payment Type               | Payment Number                    | Payment Date | Payment Amount |                     |                |
| Check                      | <a href="#">80843</a>             | 03/11/2026   | 47.25          |                     |                |
| Payable Number             | Description                       | Payable Date | Due Date       | Discount Amount     | Payable Amount |
| <a href="#">INV0005108</a> | 607 new tag & 510 registration    | 03/11/2026   | 04/10/2026     | 0.00                | 47.25          |

### Payment Summary

| Bank Code             | Type  | Payable<br>Count | Payment<br>Count | Discount    | Payment      |
|-----------------------|-------|------------------|------------------|-------------|--------------|
| General               | Check | 1                | 1                | 0.00        | 47.25        |
| <b>Packet Totals:</b> |       | <b>1</b>         | <b>1</b>         | <b>0.00</b> | <b>47.25</b> |

### Cash Fund Summary

| Fund                  | Name        | Amount        |
|-----------------------|-------------|---------------|
| 099                   | Pooled Cash | -47.25        |
| <b>Packet Totals:</b> |             | <u>-47.25</u> |



Bank: General - Community National Bank

| Vendor Number         | Vendor Name           |                     |                 |                        |                       |                       | Total Vendor Amount |
|-----------------------|-----------------------|---------------------|-----------------|------------------------|-----------------------|-----------------------|---------------------|
|                       | **Void**              |                     |                 |                        |                       |                       | 0.00                |
| <b>Payment Type</b>   | <b>Payment Number</b> |                     |                 | <b>Payment Date</b>    |                       | <b>Payment Amount</b> |                     |
| **Void EFT            | <a href="#">9394</a>  |                     |                 | 03/13/2026             |                       | 0.00                  |                     |
| <b>Payable Number</b> | <b>Description</b>    | <b>Payable Date</b> | <b>Due Date</b> | <b>Discount Amount</b> | <b>Payable Amount</b> |                       |                     |
|                       |                       |                     |                 | 0.00                   | 0.00                  |                       |                     |
| <b>Payment Type</b>   | <b>Payment Number</b> |                     |                 | <b>Payment Date</b>    |                       | <b>Payment Amount</b> |                     |
| **Void EFT            | <a href="#">9395</a>  |                     |                 | 03/13/2026             |                       | 0.00                  |                     |
| <b>Payable Number</b> | <b>Description</b>    | <b>Payable Date</b> | <b>Due Date</b> | <b>Discount Amount</b> | <b>Payable Amount</b> |                       |                     |
|                       |                       |                     |                 | 0.00                   | 0.00                  |                       |                     |
| <b>Payment Type</b>   | <b>Payment Number</b> |                     |                 | <b>Payment Date</b>    |                       | <b>Payment Amount</b> |                     |
| **Void EFT            | <a href="#">9396</a>  |                     |                 | 03/13/2026             |                       | 0.00                  |                     |
| <b>Payable Number</b> | <b>Description</b>    | <b>Payable Date</b> | <b>Due Date</b> | <b>Discount Amount</b> | <b>Payable Amount</b> |                       |                     |
|                       |                       |                     |                 | 0.00                   | 0.00                  |                       |                     |

| Vendor Number              | Vendor Name                            |                     |                 |                        |                       |                       | Total Vendor Amount |
|----------------------------|--|---------------------|-----------------|------------------------|-----------------------|-----------------------|---------------------|
| <a href="#">037784</a>     | Advanced Correctional Healthcare, Inc. |                     |                 |                        |                       |                       | 18.00               |
| <b>Payment Type</b>        | <b>Payment Number</b>                  |                     |                 | <b>Payment Date</b>    |                       | <b>Payment Amount</b> |                     |
| EFT                        | <a href="#">9380</a>                   |                     |                 | 03/13/2026             |                       | 18.00                 |                     |
| <b>Payable Number</b>      | <b>Description</b>                     | <b>Payable Date</b> | <b>Due Date</b> | <b>Discount Amount</b> | <b>Payable Amount</b> |                       |                     |
| <a href="#">INV-003564</a> | Repricing fee for Victor Moore         | 02/12/2026          | 03/14/2026      | 0.00                   | 18.00                 |                       |                     |

| Vendor Number                             | Vendor Name            |                     |                 |                        |                       |                       | Total Vendor Amount |
|---|------------------------|---------------------|-----------------|------------------------|-----------------------|-----------------------|---------------------|
| <a href="#">038325</a>                    | APAC-Kansas Inc        |                     |                 |                        |                       |                       | 374,929.17          |
| <b>Payment Type</b>                       | <b>Payment Number</b>  |                     |                 | <b>Payment Date</b>    |                       | <b>Payment Amount</b> |                     |
| EFT                                       | <a href="#">9381</a>   |                     |                 | 03/13/2026             |                       | 374,929.17            |                     |
| <b>Payable Number</b>                     | <b>Description</b>     | <b>Payable Date</b> | <b>Due Date</b> | <b>Discount Amount</b> | <b>Payable Amount</b> |                       |                     |
| <a href="#">Pump Station Pay Est No 5</a> | Big Straw Pump Station | 03/03/2026          | 03/03/2026      | 0.00                   | 374,929.17            |                       |                     |

| Vendor Number          | Vendor Name           |                     |                 |                        |                       |                       | Total Vendor Amount |
|------------------------|-----------------------|---------------------|-----------------|------------------------|-----------------------|-----------------------|---------------------|
| <a href="#">038287</a> | Ashcraft Tire & Auto  |                     |                 |                        |                       |                       | 553.43              |
| <b>Payment Type</b>    | <b>Payment Number</b> |                     |                 | <b>Payment Date</b>    |                       | <b>Payment Amount</b> |                     |
| EFT                    | <a href="#">9382</a>  |                     |                 | 03/13/2026             |                       | 553.43                |                     |
| <b>Payable Number</b>  | <b>Description</b>    | <b>Payable Date</b> | <b>Due Date</b> | <b>Discount Amount</b> | <b>Payable Amount</b> |                       |                     |
| <a href="#">051735</a> | 413 Tire change       | 02/10/2026          | 03/12/2026      | 0.00                   | 210.62                |                       |                     |
| <a href="#">051937</a> | 523 Tire Mount        | 02/26/2026          | 03/28/2026      | 0.00                   | 342.81                |                       |                     |

| Vendor Number                      | Vendor Name                        |                     |                 |                        |                       |                       | Total Vendor Amount |
|------------------------------------|------------------------------------|---------------------|-----------------|------------------------|-----------------------|-----------------------|---------------------|
| <a href="#">036926</a>             | AT&T Long Distance                 |                     |                 |                        |                       |                       | 1.96                |
| <b>Payment Type</b>                | <b>Payment Number</b>              |                     |                 | <b>Payment Date</b>    |                       | <b>Payment Amount</b> |                     |
| Check                              | <a href="#">80844</a>              |                     |                 | 03/13/2026             |                       | 1.96                  |                     |
| <b>Payable Number</b>              | <b>Description</b>                 | <b>Payable Date</b> | <b>Due Date</b> | <b>Discount Amount</b> | <b>Payable Amount</b> |                       |                     |
| <a href="#">861850574 Mar 2026</a> | AT&T Long Distance Acct #861850574 | 03/01/2026          | 03/31/2026      | 0.00                   | 1.96                  |                       |                     |

| Vendor Number              | Vendor Name           |                     |                 |                        |                       |                       | Total Vendor Amount |
|----------------------------|-----------------------|---------------------|-----------------|------------------------|-----------------------|-----------------------|---------------------|
| <a href="#">037944</a>     | Atmos                 |                     |                 |                        |                       |                       | 54.42               |
| <b>Payment Type</b>        | <b>Payment Number</b> |                     |                 | <b>Payment Date</b>    |                       | <b>Payment Amount</b> |                     |
| Check                      | <a href="#">80845</a> |                     |                 | 03/13/2026             |                       | 54.42                 |                     |
| <b>Payable Number</b>      | <b>Description</b>    | <b>Payable Date</b> | <b>Due Date</b> | <b>Discount Amount</b> | <b>Payable Amount</b> |                       |                     |
| <a href="#">INV0005115</a> | 704 N 13th Electric   | 02/26/2026          | 03/28/2026      | 0.00                   | 54.42                 |                       |                     |

**Payment Register**

APPKT01868 - 3/13/2026 AP

|  |  |                                   |                                 |  |
|--|--|-----------------------------------|---------------------------------|--|
| <b>Vendor Number</b><br><a href="#">037126</a> | <b>Vendor Name</b><br>Autozone, Inc            |                                   |                                 | <b>Total Vendor Amount</b><br>324.67         |
| <b>Payment Type</b><br>Check                   | <b>Payment Number</b><br><a href="#">80846</a> | <b>Payment Date</b><br>03/13/2026 | <b>Payment Amount</b><br>324.67 |  |
| <b>Payable Number</b>                          | <b>Description</b>                             | <b>Payable Date</b>               | <b>Due Date</b>                 | <b>Discount Amount</b> <b>Payable Amount</b> |
| <a href="#">01605614801</a>                    | Battery - Inv paid with CC                     | 10/20/2025                        | 11/19/2025                      | 0.00 -366.10                                 |
| <a href="#">01605644564-3</a>                  | Battery  | 01/07/2026                        | 02/06/2026                      | 0.00 20.00                                   |
| <a href="#">01605657047</a>                    | Brass gauges                                   | 02/09/2026                        | 03/11/2026                      | 0.00 26.98                                   |
| <a href="#">01605657078</a>                    | Brass gauges                                   | 02/09/2026                        | 03/11/2026                      | 0.00 -26.98                                  |
| <a href="#">01605657592</a>                    | Battery return                                 | 02/10/2026                        | 03/12/2026                      | 0.00 -44.00                                  |
| <a href="#">01605660339</a>                    | Battery for 420                                | 02/18/2026                        | 03/20/2026                      | 0.00 358.06                                  |
| <a href="#">01605663241</a>                    | Battery for the W/S Chevy                      | 02/25/2026                        | 03/27/2026                      | 0.00 198.99                                  |
| <a href="#">01605663244</a>                    | Returned battery                               | 02/25/2026                        | 03/27/2026                      | 0.00 -198.99                                 |
| <a href="#">01605665504</a>                    | 440 Oil and filter                             | 03/02/2026                        | 04/01/2026                      | 0.00 27.64                                   |
| <a href="#">01605665571</a>                    | Radiator cap for 440                           | 03/02/2026                        | 04/01/2026                      | 0.00 8.10                                    |
| <a href="#">01605665629</a>                    | Spark Plug and installation tools              | 03/02/2026                        | 04/01/2026                      | 0.00 111.99                                  |
| <a href="#">01605665912</a>                    | Hydraulic Oil                                  | 03/03/2026                        | 04/02/2026                      | 0.00 74.24                                   |
| <a href="#">01605665937</a>                    | Remote Control and Marine Battery              | 03/03/2026                        | 04/02/2026                      | 0.00 134.74                                  |

|  |   |                                   |                                   |   |
|--|---|-----------------------------------|-----------------------------------|---|
| <b>Vendor Number</b><br><a href="#">037918</a> | <b>Vendor Name</b><br>Baker Services Inc      |                                   |                                   | <b>Total Vendor Amount</b><br>1,527.60                        |
| <b>Payment Type</b><br>EFT                     | <b>Payment Number</b><br><a href="#">9383</a> | <b>Payment Date</b><br>03/13/2026 | <b>Payment Amount</b><br>1,527.60 |   |
| <b>Payable Number</b><br><a href="#">70637</a> | <b>Description</b><br>Ammoniom Sulfate        | <b>Payable Date</b><br>02/23/2026 | <b>Due Date</b><br>03/25/2026     | <b>Discount Amount</b> <b>Payable Amount</b><br>0.00 1,527.60 |

|   |  |                                   |                                     |   |
|---|--|-----------------------------------|-------------------------------------|---|
| <b>Vendor Number</b><br><a href="#">036828</a>                    | <b>Vendor Name</b><br>Bettis Asphalt & Construction Inc. |                                   |                                     | <b>Total Vendor Amount</b><br>405,516.00                        |
| <b>Payment Type</b><br>EFT  | <b>Payment Number</b><br><a href="#">9384</a>            | <b>Payment Date</b><br>03/13/2026 | <b>Payment Amount</b><br>405,516.00 |   |
| <b>Payable Number</b><br><a href="#">Maple Pay Request No. 17</a> | <b>Description</b><br>MAPLE ST CHANGE ORDERS             | <b>Payable Date</b><br>02/19/2026 | <b>Due Date</b><br>03/21/2026       | <b>Discount Amount</b> <b>Payable Amount</b><br>0.00 405,516.00 |

|  |   |                                   |                                   |   |
|--|---|-----------------------------------|-----------------------------------|---|
| <b>Vendor Number</b><br><a href="#">032744</a>     | <b>Vendor Name</b><br>Brenntag Southwest Inc. |                                   |                                   | <b>Total Vendor Amount</b><br>1,933.00                        |
| <b>Payment Type</b><br>EFT                         | <b>Payment Number</b><br><a href="#">9385</a> | <b>Payment Date</b><br>03/13/2026 | <b>Payment Amount</b><br>1,933.00 |   |
| <b>Payable Number</b><br><a href="#">BSW683252</a> | <b>Description</b><br>Chlorine                | <b>Payable Date</b><br>03/05/2026 | <b>Due Date</b><br>04/04/2026     | <b>Discount Amount</b> <b>Payable Amount</b><br>0.00 1,933.00 |

|   |  |                                   |                               |   |
|---|--|-----------------------------------|-------------------------------|---|
| <b>Vendor Number</b><br><a href="#">038272</a>      | <b>Vendor Name</b><br>Bureau of Motor Vehicles |                                   |                               | <b>Total Vendor Amount</b><br>4.00                        |
| <b>Payment Type</b><br>Check                        | <b>Payment Number</b><br><a href="#">80847</a> | <b>Payment Date</b><br>03/13/2026 | <b>Payment Amount</b><br>4.00 |   |
| <b>Payable Number</b><br><a href="#">INV0005111</a> | <b>Description</b><br>Certified driving record | <b>Payable Date</b><br>03/11/2026 | <b>Due Date</b><br>03/11/2026 | <b>Discount Amount</b> <b>Payable Amount</b><br>0.00 4.00 |

|  |  |                                   |                                   |   |
|--|--|-----------------------------------|-----------------------------------|---|
| <b>Vendor Number</b><br><a href="#">038174</a> | <b>Vendor Name</b><br>Casey's Automotive LLC       |                                   |                                   | <b>Total Vendor Amount</b><br>3,321.12                      |
| <b>Payment Type</b><br>Check                   | <b>Payment Number</b><br><a href="#">80848</a>     | <b>Payment Date</b><br>03/13/2026 | <b>Payment Amount</b><br>3,321.12 |   |
| <b>Payable Number</b><br><a href="#">20999</a> | <b>Description</b><br>Front strut assembly         | <b>Payable Date</b><br>03/02/2026 | <b>Due Date</b><br>03/02/2026     | <b>Discount Amount</b> <b>Payable Amount</b><br>0.00 696.88 |
| <a href="#">21010</a>                          | Motor Mount, Transmission mount, front cv axles... | 02/26/2026                        | 02/26/2026                        | 0.00 2,624.24   |

|  |   |                                   |                                     |   |
|--|---|-----------------------------------|-------------------------------------|---|
| <b>Vendor Number</b><br><a href="#">038076</a>                       | <b>Vendor Name</b><br>Cogent, Inc             |                                   |                                     | <b>Total Vendor Amount</b><br>338,982.30                        |
| <b>Payment Type</b><br>EFT   | <b>Payment Number</b><br><a href="#">9386</a> | <b>Payment Date</b><br>03/13/2026 | <b>Payment Amount</b><br>338,982.30 |   |
| <b>Payable Number</b><br><a href="#">Pipeline Pump Station Pay E</a> | <b>Description</b><br>Pipeline Pump Station   | <b>Payable Date</b><br>02/28/2026 | <b>Due Date</b><br>03/30/2026       | <b>Discount Amount</b> <b>Payable Amount</b><br>0.00 338,982.30 |

Payment Register

APPKT01868 - 3/13/2026 AP

|  |  |                                   |                               |                                   |  |   |
|--|--|-----------------------------------|-------------------------------|-----------------------------------|--|---|
| <b>Vendor Number</b><br><a href="#">036283</a>     | <b>Vendor Name</b><br>Commercial Bank                            |                                   |                               |                                   |  | <b>Total Vendor Amount</b><br>44,156.39 |
| <b>Payment Type</b><br>Check                       | <b>Payment Number</b><br><a href="#">80849</a>                   |                                   |                               | <b>Payment Date</b><br>03/13/2026 |  | <b>Payment Amount</b><br>44,156.39      |
| <b>Payable Number</b><br><a href="#">410195502</a> | <b>Description</b><br>Acct 410195502 - Bucket Truck Loan Payment | <b>Payable Date</b><br>03/03/2026 | <b>Due Date</b><br>04/02/2026 | <b>Discount Amount</b><br>0.00    |  | <b>Payable Amount</b><br>44,156.39      |

|  |   |                                   |                               |                                   |  |  |
|--|---|-----------------------------------|-------------------------------|-----------------------------------|--|--|
| <b>Vendor Number</b><br><a href="#">034221</a>   | <b>Vendor Name</b><br>Core & Main                 |                                   |                               |                                   |  | <b>Total Vendor Amount</b><br>1,874.32 |
| <b>Payment Type</b><br>EFT                       | <b>Payment Number</b><br><a href="#">9387</a>     |                                   |                               | <b>Payment Date</b><br>03/13/2026 |  | <b>Payment Amount</b><br>1,874.32      |
| <b>Payable Number</b><br><a href="#">Y327264</a> | <b>Description</b><br>Flange and installation kit | <b>Payable Date</b><br>02/13/2026 | <b>Due Date</b><br>03/15/2026 | <b>Discount Amount</b><br>0.00    |  | <b>Payable Amount</b><br>549.50        |
| <a href="#">Y488896</a>                          | Brass Couplings and Green Sewer Dye               | 02/13/2026                        | 03/15/2026                    | 0.00                              |  | 72.50                                  |
| <a href="#">Y493325</a>                          | 250 PSI Blue Tubing                               | 02/13/2026                        | 03/15/2026                    | 0.00                              |  | 1,170.00                               |
| <a href="#">Y519472</a>                          | Green Sewer Dye                                   | 02/13/2026                        | 03/15/2026                    | 0.00                              |  | 82.32                                  |

|  |   |                                   |                               |                                   |  |  |
|--|---|-----------------------------------|-------------------------------|-----------------------------------|--|--|
| <b>Vendor Number</b><br><a href="#">032078</a> | <b>Vendor Name</b><br>CPR Pest Management, Inc. |                                   |                               |                                   |  | <b>Total Vendor Amount</b><br>1,460.00 |
| <b>Payment Type</b><br>EFT                     | <b>Payment Number</b><br><a href="#">9388</a>   |                                   |                               | <b>Payment Date</b><br>03/13/2026 |  | <b>Payment Amount</b><br>1,460.00      |
| <b>Payable Number</b><br><a href="#">49547</a> | <b>Description</b><br>PT #114                   | <b>Payable Date</b><br>01/06/2026 | <b>Due Date</b><br>03/13/2026 | <b>Discount Amount</b><br>0.00    |  | <b>Payable Amount</b><br>700.00        |
| <a href="#">49975</a>                          | McKinley Pest Control #1009A                    | 02/13/2026                        | 03/15/2026                    | 0.00                              |  | 700.00                                 |
| <a href="#">50261</a>                          | Library Monthly Pest Control                    | 03/09/2026                        | 04/08/2026                    | 0.00                              |  | 60.00                                  |

|  |   |                                   |                               |                                   |  |                                      |
|--|---|-----------------------------------|-------------------------------|-----------------------------------|--|--------------------------------------|
| <b>Vendor Number</b><br><a href="#">035070</a> | <b>Vendor Name</b><br>D&F Services, LLC                         |                                   |                               |                                   |  | <b>Total Vendor Amount</b><br>800.00 |
| <b>Payment Type</b><br>EFT                     | <b>Payment Number</b><br><a href="#">9389</a>                   |                                   |                               | <b>Payment Date</b><br>03/13/2026 |  | <b>Payment Amount</b><br>800.00      |
| <b>Payable Number</b><br><a href="#">7634</a>  | <b>Description</b><br>Chlorine Dioxide System Maint. and Repair | <b>Payable Date</b><br>02/27/2026 | <b>Due Date</b><br>03/29/2026 | <b>Discount Amount</b><br>0.00    |  | <b>Payable Amount</b><br>800.00      |

|   |   |                                   |                               |                                   |  |                                      |
|---|---|-----------------------------------|-------------------------------|-----------------------------------|--|--------------------------------------|
| <b>Vendor Number</b><br><a href="#">038368</a>      | <b>Vendor Name</b><br>Dustin Burdett          |                                   |                               |                                   |  | <b>Total Vendor Amount</b><br>110.51 |
| <b>Payment Type</b><br>EFT                          | <b>Payment Number</b><br><a href="#">9390</a> |                                   |                               | <b>Payment Date</b><br>03/13/2026 |  | <b>Payment Amount</b><br>110.51      |
| <b>Payable Number</b><br><a href="#">INV0005114</a> | <b>Description</b><br>Meals for training      | <b>Payable Date</b><br>03/06/2026 | <b>Due Date</b><br>03/06/2026 | <b>Discount Amount</b><br>0.00    |  | <b>Payable Amount</b><br>110.51      |

|   |  |                                   |                               |                                   |  |  |
|---|--|-----------------------------------|-------------------------------|-----------------------------------|--|--|
| <b>Vendor Number</b><br><a href="#">036278</a>  | <b>Vendor Name</b><br>Elliott Equipment Co.    |                                   |                               |                                   |  | <b>Total Vendor Amount</b><br>1,154.59 |
| <b>Payment Type</b><br>Check                    | <b>Payment Number</b><br><a href="#">80850</a> |                                   |                               | <b>Payment Date</b><br>03/13/2026 |  | <b>Payment Amount</b><br>1,154.59      |
| <b>Payable Number</b><br><a href="#">191949</a> | <b>Description</b><br>Gutter Broom Set         | <b>Payable Date</b><br>02/25/2026 | <b>Due Date</b><br>03/27/2026 | <b>Discount Amount</b><br>0.00    |  | <b>Payable Amount</b><br>1,154.59      |

|  |   |                                   |                               |                                   |  |                                      |
|--|---|-----------------------------------|-------------------------------|-----------------------------------|--|--------------------------------------|
| <b>Vendor Number</b><br><a href="#">035721</a> | <b>Vendor Name</b><br>Emert Chubb LLC         |                                   |                               |                                   |  | <b>Total Vendor Amount</b><br>475.00 |
| <b>Payment Type</b><br>EFT                     | <b>Payment Number</b><br><a href="#">9391</a> |                                   |                               | <b>Payment Date</b><br>03/13/2026 |  | <b>Payment Amount</b><br>475.00      |
| <b>Payable Number</b><br><a href="#">12287</a> | <b>Description</b><br>1104 W. Main            | <b>Payable Date</b><br>03/01/2026 | <b>Due Date</b><br>03/31/2026 | <b>Discount Amount</b><br>0.00    |  | <b>Payable Amount</b><br>475.00      |

|   |   |                                   |                               |                                   |  |                                      |
|---|---|-----------------------------------|-------------------------------|-----------------------------------|--|--------------------------------------|
| <b>Vendor Number</b><br><a href="#">032155</a>      | <b>Vendor Name</b><br>Family Support Payment Center |                                   |                               |                                   |  | <b>Total Vendor Amount</b><br>173.08 |
| <b>Payment Type</b><br>Check                        | <b>Payment Number</b><br><a href="#">80851</a>      |                                   |                               | <b>Payment Date</b><br>03/13/2026 |  | <b>Payment Amount</b><br>173.08      |
| <b>Payable Number</b><br><a href="#">INV0005144</a> | <b>Description</b><br>[REDACTED]                    | <b>Payable Date</b><br>03/13/2026 | <b>Due Date</b><br>03/13/2026 | <b>Discount Amount</b><br>0.00    |  | <b>Payable Amount</b><br>173.08      |

**Payment Register**

**APPKT01868 - 3/13/2026 AP**

| Vendor Number              | Vendor Name                               |                     |                 |                        |                       | Total Vendor Amount        |
|----------------------------|---|---------------------|-----------------|------------------------|-----------------------|----------------------------|
| <a href="#">037139</a>     | Fleet Fuels, LLC                          |                     |                 |                        |                       | 1,790.21                   |
| <b>Payment Type</b>        | <b>Payment Number</b>                     |                     |                 | <b>Payment Date</b>    |                       | <b>Payment Amount</b>      |
| EFT                        | <a href="#">9392</a>                      |                     |                 | 03/13/2026             |                       | 1,790.21                   |
| <b>Payable Number</b>      | <b>Description</b>                        | <b>Payable Date</b> | <b>Due Date</b> | <b>Discount Amount</b> | <b>Payable Amount</b> |                            |
| <a href="#">CFSI-46099</a> | Fuel                                      | 02/15/2026          | 03/17/2026      | 0.00                   | 50.97                 |                            |
| <a href="#">CFSI-48438</a> | Fuel                                      | 03/01/2026          | 03/31/2026      | 0.00                   | 40.89                 |                            |
| <a href="#">SI-63422</a>   | Diesel Fuel                               | 02/24/2026          | 03/26/2026      | 0.00                   | 1,698.35              |                            |
| <b>Vendor Number</b>       | <b>Vendor Name</b>                        |                     |                 |                        |                       | <b>Total Vendor Amount</b> |
| <a href="#">033568</a>     | Galaxie Business                          |                     |                 |                        |                       | 7,235.90                   |
| <b>Payment Type</b>        | <b>Payment Number</b>                     |                     |                 | <b>Payment Date</b>    |                       | <b>Payment Amount</b>      |
| EFT                        | <a href="#">9393</a>                      |                     |                 | 03/13/2026             |                       | 7,235.90                   |
| <b>Payable Number</b>      | <b>Description</b>                        | <b>Payable Date</b> | <b>Due Date</b> | <b>Discount Amount</b> | <b>Payable Amount</b> |                            |
| <a href="#">149221</a>     | Monthly Subscriptions                     | 03/09/2026          | 04/08/2026      | 0.00                   | 5,982.40              |                            |
| <a href="#">149222</a>     | Monthly Subscription - PD/Dispatch        | 03/09/2026          | 04/08/2026      | 0.00                   | 1,253.50              |                            |
| <b>Vendor Number</b>       | <b>Vendor Name</b>                        |                     |                 |                        |                       | <b>Total Vendor Amount</b> |
| <a href="#">009330</a>     | Grainger                                  |                     |                 |                        |                       | 22.08                      |
| <b>Payment Type</b>        | <b>Payment Number</b>                     |                     |                 | <b>Payment Date</b>    |                       | <b>Payment Amount</b>      |
| EFT                        | <a href="#">9397</a>                      |                     |                 | 03/13/2026             |                       | 22.08                      |
| <b>Payable Number</b>      | <b>Description</b>                        | <b>Payable Date</b> | <b>Due Date</b> | <b>Discount Amount</b> | <b>Payable Amount</b> |                            |
| <a href="#">9826072952</a> | Ear Plugs                                 | 03/02/2026          | 04/01/2026      | 0.00                   | 22.08                 |                            |
| <b>Vendor Number</b>       | <b>Vendor Name</b>                        |                     |                 |                        |                       | <b>Total Vendor Amount</b> |
| <a href="#">037488</a>     | Healy Law Offices, LLC                    |                     |                 |                        |                       | 350.00                     |
| <b>Payment Type</b>        | <b>Payment Number</b>                     |                     |                 | <b>Payment Date</b>    |                       | <b>Payment Amount</b>      |
| EFT                        | <a href="#">9398</a>                      |                     |                 | 03/13/2026             |                       | 350.00                     |
| <b>Payable Number</b>      | <b>Description</b>                        | <b>Payable Date</b> | <b>Due Date</b> | <b>Discount Amount</b> | <b>Payable Amount</b> |                            |
| <a href="#">23303</a>      | Kwikom                                    | 02/28/2026          | 03/30/2026      | 0.00                   | 350.00                |                            |
| <b>Vendor Number</b>       | <b>Vendor Name</b>                        |                     |                 |                        |                       | <b>Total Vendor Amount</b> |
| <a href="#">010440</a>     | Hugo's Industrial Supply                  |                     |                 |                        |                       | 1,731.28                   |
| <b>Payment Type</b>        | <b>Payment Number</b>                     |                     |                 | <b>Payment Date</b>    |                       | <b>Payment Amount</b>      |
| EFT                        | <a href="#">9399</a>                      |                     |                 | 03/13/2026             |                       | 1,731.28                   |
| <b>Payable Number</b>      | <b>Description</b>                        | <b>Payable Date</b> | <b>Due Date</b> | <b>Discount Amount</b> | <b>Payable Amount</b> |                            |
| <a href="#">347636</a>     | Mop, Bucket, Paper                        | 01/28/2026          | 02/27/2026      | 0.00                   | 214.77                |                            |
| <a href="#">348126</a>     | Floor Dry                                 | 02/09/2026          | 03/11/2026      | 0.00                   | 1,000.80              |                            |
| <a href="#">348816</a>     | Lysol Wipes/ Scotch Magic Tape            | 02/24/2026          | 03/26/2026      | 0.00                   | 52.48                 |                            |
| <a href="#">349211</a>     | Wrist rest                                | 03/13/2026          | 04/12/2026      | 0.00                   | 63.79                 |                            |
| <a href="#">349223</a>     | Toner & paper                             | 03/06/2026          | 04/05/2026      | 0.00                   | 399.44                |                            |
| <b>Vendor Number</b>       | <b>Vendor Name</b>                        |                     |                 |                        |                       | <b>Total Vendor Amount</b> |
| <a href="#">011120</a>     | Independence Chamber of Commerce          |                     |                 |                        |                       | 100.00                     |
| <b>Payment Type</b>        | <b>Payment Number</b>                     |                     |                 | <b>Payment Date</b>    |                       | <b>Payment Amount</b>      |
| Check                      | <a href="#">80852</a>                     |                     |                 | 03/13/2026             |                       | 100.00                     |
| <b>Payable Number</b>      | <b>Description</b>                        | <b>Payable Date</b> | <b>Due Date</b> | <b>Discount Amount</b> | <b>Payable Amount</b> |                            |
| <a href="#">3878</a>       | Lunch and Learn leadership training       | 11/12/2025          | 12/12/2025      | 0.00                   | 100.00                |                            |
| <b>Vendor Number</b>       | <b>Vendor Name</b>                        |                     |                 |                        |                       | <b>Total Vendor Amount</b> |
| <a href="#">011180</a>     | Independence Community                    |                     |                 |                        |                       | 5.00                       |
| <b>Payment Type</b>        | <b>Payment Number</b>                     |                     |                 | <b>Payment Date</b>    |                       | <b>Payment Amount</b>      |
| EFT                        | <a href="#">9400</a>                      |                     |                 | 03/13/2026             |                       | 5.00                       |
| <b>Payable Number</b>      | <b>Description</b>                        | <b>Payable Date</b> | <b>Due Date</b> | <b>Discount Amount</b> | <b>Payable Amount</b> |                            |
| <a href="#">INV0005120</a> | Charitable Contribution - Employee Direct | 03/13/2026          | 03/13/2026      | 0.00                   | 5.00                  |                            |
| <b>Vendor Number</b>       | <b>Vendor Name</b>                        |                     |                 |                        |                       | <b>Total Vendor Amount</b> |
| <a href="#">011200</a>     | Independence Daily Reporter               |                     |                 |                        |                       | 1,314.28                   |
| <b>Payment Type</b>        | <b>Payment Number</b>                     |                     |                 | <b>Payment Date</b>    |                       | <b>Payment Amount</b>      |
| EFT                        | <a href="#">9401</a>                      |                     |                 | 03/13/2026             |                       | 1,314.28                   |
| <b>Payable Number</b>      | <b>Description</b>                        | <b>Payable Date</b> | <b>Due Date</b> | <b>Discount Amount</b> | <b>Payable Amount</b> |                            |
| <a href="#">98002</a>      | Res. 2026-019 legal notice                | 02/05/2026          | 03/07/2026      | 0.00                   | 94.80                 |                            |

**Payment Register**

**APPKT01868 - 3/13/2026 AP**

|                            |                                       |            |            |      |        |
|----------------------------|---------------------------------------|------------|------------|------|--------|
| <a href="#">98003</a>      | Res 2026-018 legal notice             | 02/05/2026 | 03/07/2026 | 0.00 | 94.80  |
| <a href="#">98090</a>      | Res 2026-025 legal notice             | 02/21/2026 | 03/23/2026 | 0.00 | 69.52  |
| <a href="#">98091</a>      | Res 2026-022 legal notice             | 02/21/2026 | 03/23/2026 | 0.00 | 69.52  |
| <a href="#">98092</a>      | Res 2026-026 legal notice             | 02/21/2026 | 03/23/2026 | 0.00 | 69.52  |
| <a href="#">98093</a>      | Res 2026-023 legal notice             | 02/21/2026 | 03/23/2026 | 0.00 | 69.52  |
| <a href="#">98094</a>      | Res 2026-021 legal notice             | 02/21/2026 | 03/23/2026 | 0.00 | 69.52  |
| <a href="#">98291</a>      | Res 2026-028 legal notice             | 02/28/2026 | 03/30/2026 | 0.00 | 139.04 |
| <a href="#">98292</a>      | Res 2026-029 legal notice             | 02/28/2026 | 03/30/2026 | 0.00 | 139.04 |
| <a href="#">98357</a>      | Best of Independence Ad               | 02/28/2026 | 03/30/2026 | 0.00 | 375.00 |
| <a href="#">INV0005116</a> | Penn Terrace Office Newspaper Renewal | 02/26/2026 | 03/28/2026 | 0.00 | 124.00 |

|                            |                           |                     |                       |                            |                       |
|----------------------------|---------------------------|---------------------|-----------------------|----------------------------|-----------------------|
| <b>Vendor Number</b>       | <b>Vendor Name</b>        |                     |                       | <b>Total Vendor Amount</b> |                       |
| <a href="#">011211</a>     | Independence Fire Fighter |                     |                       | 157.50                     |                       |
| <b>Payment Type</b>        | <b>Payment Number</b>     | <b>Payment Date</b> | <b>Payment Amount</b> |                            |                       |
| EFT                        | <a href="#">9402</a>      | 03/13/2026          | 157.50                |                            |                       |
| <b>Payable Number</b>      | <b>Description</b>        | <b>Payable Date</b> | <b>Due Date</b>       | <b>Discount Amount</b>     | <b>Payable Amount</b> |
| <a href="#">INV0005122</a> | Fire Insurance            | 03/13/2026          | 03/13/2026            | 0.00                       | 157.50                |

|                            |                                    |                     |                       |                            |                       |
|----------------------------|------------------------------------|---------------------|-----------------------|----------------------------|-----------------------|
| <b>Vendor Number</b>       | <b>Vendor Name</b>                 |                     |                       | <b>Total Vendor Amount</b> |                       |
| <a href="#">033149</a>     | Independence Firemen's Association |                     |                       | 210.00                     |                       |
| <b>Payment Type</b>        | <b>Payment Number</b>              | <b>Payment Date</b> | <b>Payment Amount</b> |                            |                       |
| EFT                        | <a href="#">9403</a>               | 03/13/2026          | 210.00                |                            |                       |
| <b>Payable Number</b>      | <b>Description</b>                 | <b>Payable Date</b> | <b>Due Date</b>       | <b>Discount Amount</b>     | <b>Payable Amount</b> |
| <a href="#">INV0005121</a> | Funding/ Firemen's Association     | 03/13/2026          | 03/13/2026            | 0.00                       | 210.00                |

|                        |                                 |                     |                       |                            |                       |
|------------------------|---------------------------------|---------------------|-----------------------|----------------------------|-----------------------|
| <b>Vendor Number</b>   | <b>Vendor Name</b>              |                     |                       | <b>Total Vendor Amount</b> |                       |
| <a href="#">011215</a> | Independence Main Street        |                     |                       | 304.00                     |                       |
| <b>Payment Type</b>    | <b>Payment Number</b>           | <b>Payment Date</b> | <b>Payment Amount</b> |                            |                       |
| EFT                    | <a href="#">9404</a>            | 03/13/2026          | 304.00                |                            |                       |
| <b>Payable Number</b>  | <b>Description</b>              | <b>Payable Date</b> | <b>Due Date</b>       | <b>Discount Amount</b>     | <b>Payable Amount</b> |
| <a href="#">002</a>    | 2026 Annual Fundraiser Donation | 03/07/2026          | 04/06/2026            | 0.00                       | 100.00                |
| <a href="#">326</a>    | Fundraiser tickets              | 03/09/2026          | 04/08/2026            | 0.00                       | 204.00                |

|                            |                          |                     |                       |                            |                       |
|----------------------------|--------------------------|---------------------|-----------------------|----------------------------|-----------------------|
| <b>Vendor Number</b>       | <b>Vendor Name</b>       |                     |                       | <b>Total Vendor Amount</b> |                       |
| <a href="#">037321</a>     | Internal Revenue Service |                     |                       | 242.88                     |                       |
| <b>Payment Type</b>        | <b>Payment Number</b>    | <b>Payment Date</b> | <b>Payment Amount</b> |                            |                       |
| Check                      | <a href="#">80853</a>    | 03/13/2026          | 242.88                |                            |                       |
| <b>Payable Number</b>      | <b>Description</b>       | <b>Payable Date</b> | <b>Due Date</b>       | <b>Discount Amount</b>     | <b>Payable Amount</b> |
| <a href="#">INV0005128</a> | Tax Levy                 | 03/13/2026          | 03/13/2026            | 0.00                       | 242.88                |

|  |  |                     |                       |                            |                       |
|--|--|---------------------|-----------------------|----------------------------|-----------------------|
| <b>Vendor Number</b>                       | <b>Vendor Name</b>                       |                     |                       | <b>Total Vendor Amount</b> |                       |
| <a href="#">037194</a>                     | J Graham Construction Inc.               |                     |                       | 87,987.10                  |                       |
| <b>Payment Type</b>                        | <b>Payment Number</b>                    | <b>Payment Date</b> | <b>Payment Amount</b> |                            |                       |
| EFT  | <a href="#">9405</a>                     | 03/13/2026          | 87,987.10             |                            |                       |
| <b>Payable Number</b>                      | <b>Description</b>                       | <b>Payable Date</b> | <b>Due Date</b>       | <b>Discount Amount</b>     | <b>Payable Amount</b> |
| <a href="#">Beech Street Pay Request N</a> | Beech Street Culvert Replacement Project | 02/19/2026          | 03/21/2026            | 0.00                       | 63,877.50             |
| <a href="#">Beech Street Pay Request N</a> | Beech Street Culvert Replacement Project | 03/03/2026          | 04/02/2026            | 0.00                       | 24,109.60             |

|                          |                           |                     |                       |                            |                       |
|--------------------------|---------------------------|---------------------|-----------------------|----------------------------|-----------------------|
| <b>Vendor Number</b>     | <b>Vendor Name</b>        |                     |                       | <b>Total Vendor Amount</b> |                       |
| <a href="#">038232</a>   | Janet Leasure             |                     |                       | 55.00                      |                       |
| <b>Payment Type</b>      | <b>Payment Number</b>     | <b>Payment Date</b> | <b>Payment Amount</b> |                            |                       |
| Check                    | <a href="#">80854</a>     | 03/13/2026          | 55.00                 |                            |                       |
| <b>Payable Number</b>    | <b>Description</b>        | <b>Payable Date</b> | <b>Due Date</b>       | <b>Discount Amount</b>     | <b>Payable Amount</b> |
| <a href="#">3/3/2026</a> | Patches and hemming pants | 03/03/2026          | 03/03/2026            | 0.00                       | 55.00                 |

|                            |                       |                     |                       |                            |                       |
|----------------------------|-----------------------|---------------------|-----------------------|----------------------------|-----------------------|
| <b>Vendor Number</b>       | <b>Vendor Name</b>    |                     |                       | <b>Total Vendor Amount</b> |                       |
| <a href="#">032449</a>     | Kansas Payment Center |                     |                       | 320.76                     |                       |
| <b>Payment Type</b>        | <b>Payment Number</b> | <b>Payment Date</b> | <b>Payment Amount</b> |                            |                       |
| Check                      | <a href="#">80855</a> | 03/13/2026          | 320.76                |                            |                       |
| <b>Payable Number</b>      | <b>Description</b>    | <b>Payable Date</b> | <b>Due Date</b>       | <b>Discount Amount</b>     | <b>Payable Amount</b> |
| <a href="#">INV0005141</a> | [REDACTED]            | 03/13/2026          | 03/13/2026            | 0.00                       | 144.92                |
| <a href="#">INV0005142</a> | [REDACTED]            | 03/13/2026          | 03/13/2026            | 0.00                       | 84.92                 |

Payment Register

APPKT01868 - 3/13/2026 AP

|                               |                                      |  |                     |                 |                        |                            |  |
|-------------------------------|--------------------------------------|--|---------------------|-----------------|------------------------|----------------------------|--|
| <a href="#">INV0005143</a>    |                                      |  | 03/13/2026          | 03/13/2026      | 0.00                   | 90.92                      |  |
| <b>Vendor Number</b>          | <b>Vendor Name</b>                   |  |                     |                 |                        | <b>Total Vendor Amount</b> |  |
| <a href="#">037128</a>        | Kelley Electric Inc.                 |  |                     |                 |                        | 750.00                     |  |
| <b>Payment Type</b>           | <b>Payment Number</b>                |  |                     |                 | <b>Payment Date</b>    | <b>Payment Amount</b>      |  |
| EFT                           | <a href="#">9406</a>                 |  |                     |                 | 03/13/2026             | 750.00                     |  |
| <b>Payable Number</b>         | <b>Description</b>                   |  | <b>Payable Date</b> | <b>Due Date</b> | <b>Discount Amount</b> | <b>Payable Amount</b>      |  |
| <a href="#">2996</a>          | LED Light installation               |  | 03/02/2026          | 04/01/2026      | 0.00                   | 750.00                     |  |
| <b>Vendor Number</b>          | <b>Vendor Name</b>                   |  |                     |                 |                        | <b>Total Vendor Amount</b> |  |
| <a href="#">033182</a>        | Lakeland Office Systems              |  |                     |                 |                        | 207.15                     |  |
| <b>Payment Type</b>           | <b>Payment Number</b>                |  |                     |                 | <b>Payment Date</b>    | <b>Payment Amount</b>      |  |
| Check                         | <a href="#">80856</a>                |  |                     |                 | 03/13/2026             | 207.15                     |  |
| <b>Payable Number</b>         | <b>Description</b>                   |  | <b>Payable Date</b> | <b>Due Date</b> | <b>Discount Amount</b> | <b>Payable Amount</b>      |  |
| <a href="#">IN698673 2025</a> | Mthly Service + overage              |  | 01/12/2026          | 02/11/2026      | 0.00                   | 12.91                      |  |
| <a href="#">IN698673 2026</a> | Mthly Service + overage              |  | 01/12/2026          | 02/11/2026      | 0.00                   | 70.81                      |  |
| <a href="#">IN705219</a>      | Mthly Service + overage              |  | 02/11/2026          | 03/13/2026      | 0.00                   | 123.43                     |  |
| <b>Vendor Number</b>          | <b>Vendor Name</b>                   |  |                     |                 |                        | <b>Total Vendor Amount</b> |  |
| <a href="#">037945</a>        | Leo On Guard LLC                     |  |                     |                 |                        | 325.00                     |  |
| <b>Payment Type</b>           | <b>Payment Number</b>                |  |                     |                 | <b>Payment Date</b>    | <b>Payment Amount</b>      |  |
| Check                         | <a href="#">80857</a>                |  |                     |                 | 03/13/2026             | 325.00                     |  |
| <b>Payable Number</b>         | <b>Description</b>                   |  | <b>Payable Date</b> | <b>Due Date</b> | <b>Discount Amount</b> | <b>Payable Amount</b>      |  |
| <a href="#">INV0005110</a>    | Background for B. Schwatken          |  | 01/05/2026          | 02/04/2026      | 0.00                   | 325.00                     |  |
| <b>Vendor Number</b>          | <b>Vendor Name</b>                   |  |                     |                 |                        | <b>Total Vendor Amount</b> |  |
| <a href="#">035478</a>        | Lochner, H.W. Inc.                   |  |                     |                 |                        | 28,834.00                  |  |
| <b>Payment Type</b>           | <b>Payment Number</b>                |  |                     |                 | <b>Payment Date</b>    | <b>Payment Amount</b>      |  |
| EFT                           | <a href="#">9407</a>                 |  |                     |                 | 03/13/2026             | 28,834.00                  |  |
| <b>Payable Number</b>         | <b>Description</b>                   |  | <b>Payable Date</b> | <b>Due Date</b> | <b>Discount Amount</b> | <b>Payable Amount</b>      |  |
| <a href="#">000026002-1</a>   | Airport Runway Rehabilitation Design |  | 02/03/2026          | 03/05/2026      | 0.00                   | 28,834.00                  |  |
| <b>Vendor Number</b>          | <b>Vendor Name</b>                   |  |                     |                 |                        | <b>Total Vendor Amount</b> |  |
| <a href="#">032556</a>        | Midwest Minerals, LLC                |  |                     |                 |                        | 432.60                     |  |
| <b>Payment Type</b>           | <b>Payment Number</b>                |  |                     |                 | <b>Payment Date</b>    | <b>Payment Amount</b>      |  |
| EFT                           | <a href="#">9408</a>                 |  |                     |                 | 03/13/2026             | 432.60                     |  |
| <b>Payable Number</b>         | <b>Description</b>                   |  | <b>Payable Date</b> | <b>Due Date</b> | <b>Discount Amount</b> | <b>Payable Amount</b>      |  |
| <a href="#">838392</a>        | Rock                                 |  | 02/24/2026          | 03/26/2026      | 0.00                   | 432.60                     |  |
| <b>Vendor Number</b>          | <b>Vendor Name</b>                   |  |                     |                 |                        | <b>Total Vendor Amount</b> |  |
| <a href="#">027225</a>        | Oil Patch Pump & Supply Inc.         |  |                     |                 |                        | 688.68                     |  |
| <b>Payment Type</b>           | <b>Payment Number</b>                |  |                     |                 | <b>Payment Date</b>    | <b>Payment Amount</b>      |  |
| EFT                           | <a href="#">9409</a>                 |  |                     |                 | 03/13/2026             | 688.68                     |  |
| <b>Payable Number</b>         | <b>Description</b>                   |  | <b>Payable Date</b> | <b>Due Date</b> | <b>Discount Amount</b> | <b>Payable Amount</b>      |  |
| <a href="#">3006732</a>       | Hose, Clamps, and Couplers           |  | 02/09/2026          | 03/11/2026      | 0.00                   | 413.87                     |  |
| <a href="#">3006872</a>       | Adaptors and Lubricant               |  | 03/04/2026          | 04/03/2026      | 0.00                   | 274.81                     |  |
| <b>Vendor Number</b>          | <b>Vendor Name</b>                   |  |                     |                 |                        | <b>Total Vendor Amount</b> |  |
| <a href="#">018120</a>        | O'Reilly Auto Parts                  |  |                     |                 |                        | 9.16                       |  |
| <b>Payment Type</b>           | <b>Payment Number</b>                |  |                     |                 | <b>Payment Date</b>    | <b>Payment Amount</b>      |  |
| Check                         | <a href="#">80858</a>                |  |                     |                 | 03/13/2026             | 9.16                       |  |
| <b>Payable Number</b>         | <b>Description</b>                   |  | <b>Payable Date</b> | <b>Due Date</b> | <b>Discount Amount</b> | <b>Payable Amount</b>      |  |
| <a href="#">0154-280359</a>   | Shift knob & lift support            |  | 10/27/2025          | 11/26/2025      | 0.00                   | 39.85                      |  |
| <a href="#">0154-282175-2</a> | Mini lamp                            |  | 11/07/2025          | 12/07/2025      | 0.00                   | 6.59                       |  |
| <a href="#">0154-299420</a>   | Motor oil                            |  | 02/23/2026          | 03/25/2026      | 0.00                   | 21.98                      |  |
| <a href="#">0154-302301</a>   | vehicle parts                        |  | 03/10/2026          | 04/09/2026      | 0.00                   | 40.22                      |  |
| <a href="#">OPCM-95392</a>    | Duplicate payment Inv 0154-279709    |  | 10/23/2025          | 11/22/2025      | 0.00                   | -89.05                     |  |
| <a href="#">OPCM-98078</a>    | Duplicate payment Inv 0154-284537    |  | 11/20/2025          | 12/20/2025      | 0.00                   | -10.40                     |  |
| <a href="#">OSSO0828675</a>   | Overpayment on inv 0154-280388       |  | 11/12/2025          | 12/12/2025      | 0.00                   | -0.03                      |  |

Payment Register

APPKT01868 - 3/13/2026 AP

| Vendor Number                     | Vendor Name                                |  |                     |                     |                        | Total Vendor Amount   |
|-----------------------------------|--|--|---------------------|---------------------|------------------------|-----------------------|
| <a href="#">038152</a>            | Pappas Hayden Westberg & Jackson PC        |  |                     |                     |                        | 498.79                |
| <b>Payment Type</b>               | <b>Payment Number</b>                      |  |                     | <b>Payment Date</b> |                        | <b>Payment Amount</b> |
| Check                             | <a href="#">80859</a>                      |  |                     | 03/13/2026          |                        | 498.79                |
| <b>Payable Number</b>             | <b>Description</b>                         |  | <b>Payable Date</b> | <b>Due Date</b>     | <b>Discount Amount</b> | <b>Payable Amount</b> |
| <a href="#">INV0005145</a>        |  |  | 03/13/2026          | 03/13/2026          | 0.00                   | 498.79                |
| <a href="#">006250</a>            | Pharham Bakery, Inc. (Daylight Donuts)     |  |                     |                     |                        | 57.17                 |
| <b>Payment Type</b>               | <b>Payment Number</b>                      |  |                     | <b>Payment Date</b> |                        | <b>Payment Amount</b> |
| Check                             | <a href="#">80860</a>                      |  |                     | 03/13/2026          |                        | 57.17                 |
| <b>Payable Number</b>             | <b>Description</b>                         |  | <b>Payable Date</b> | <b>Due Date</b>     | <b>Discount Amount</b> | <b>Payable Amount</b> |
| <a href="#">7E5XTOM4C9NJT</a>     | Community Strategic Plan Meeting           |  | 03/06/2026          | 04/05/2026          | 0.00                   | 57.17                 |
| <a href="#">035995</a>            | Red Equipment, LLC                         |  |                     |                     |                        | 1,438.42              |
| <b>Payment Type</b>               | <b>Payment Number</b>                      |  |                     | <b>Payment Date</b> |                        | <b>Payment Amount</b> |
| EFT                               | <a href="#">9410</a>                       |  |                     | 03/13/2026          |                        | 1,438.42              |
| <b>Payable Number</b>             | <b>Description</b>                         |  | <b>Payable Date</b> | <b>Due Date</b>     | <b>Discount Amount</b> | <b>Payable Amount</b> |
| <a href="#">P02568</a>            | Hose assembly                              |  | 02/13/2026          | 03/15/2026          | 0.00                   | 392.27                |
| <a href="#">P02605</a>            | Hydro Lance and Nozzle                     |  | 02/19/2026          | 03/21/2026          | 0.00                   | 1,046.15              |
| <a href="#">037679</a>            | S&P Global Ratings                         |  |                     |                     |                        | 12,962.00             |
| <b>Payment Type</b>               | <b>Payment Number</b>                      |  |                     | <b>Payment Date</b> |                        | <b>Payment Amount</b> |
| EFT                               | <a href="#">9411</a>                       |  |                     | 03/13/2026          |                        | 12,962.00             |
| <b>Payable Number</b>             | <b>Description</b>                         |  | <b>Payable Date</b> | <b>Due Date</b>     | <b>Discount Amount</b> | <b>Payable Amount</b> |
| <a href="#">11500526</a>          | Analytical services Series 2025-B Issuance |  | 07/01/2025          | 07/31/2025          | 0.00                   | 12,962.00             |
| <a href="#">022110</a>            | Sayers Ace Hardware Inc.                   |  |                     |                     |                        | 119.92                |
| <b>Payment Type</b>               | <b>Payment Number</b>                      |  |                     | <b>Payment Date</b> |                        | <b>Payment Amount</b> |
| Check                             | <a href="#">80861</a>                      |  |                     | 03/13/2026          |                        | 119.92                |
| <b>Payable Number</b>             | <b>Description</b>                         |  | <b>Payable Date</b> | <b>Due Date</b>     | <b>Discount Amount</b> | <b>Payable Amount</b> |
| <a href="#">69718</a>             | Drain Unclogger                            |  | 01/09/2026          | 02/08/2026          | 0.00                   | 16.99                 |
| <a href="#">69875</a>             | Appliance Epoxy                            |  | 02/05/2026          | 03/13/2026          | 0.00                   | 43.96                 |
| <a href="#">69975</a>             | Shower Head/Valve                          |  | 02/24/2026          | 03/26/2026          | 0.00                   | 58.97                 |
| <a href="#">038159</a>            | Schindler Elevator Corporation             |  |                     |                     |                        | 3,166.76              |
| <b>Payment Type</b>               | <b>Payment Number</b>                      |  |                     | <b>Payment Date</b> |                        | <b>Payment Amount</b> |
| Check                             | <a href="#">80862</a>                      |  |                     | 03/13/2026          |                        | 3,166.76              |
| <b>Payable Number</b>             | <b>Description</b>                         |  | <b>Payable Date</b> | <b>Due Date</b>     | <b>Discount Amount</b> | <b>Payable Amount</b> |
| <a href="#">4607398884</a>        | PT Elevator                                |  | 03/01/2026          | 03/01/2026          | 0.00                   | 3,166.76              |
| <a href="#">036694</a>            | Schulte Supply                             |  |                     |                     |                        | 3,835.82              |
| <b>Payment Type</b>               | <b>Payment Number</b>                      |  |                     | <b>Payment Date</b> |                        | <b>Payment Amount</b> |
| EFT                               | <a href="#">9412</a>                       |  |                     | 03/13/2026          |                        | 3,835.82              |
| <b>Payable Number</b>             | <b>Description</b>                         |  | <b>Payable Date</b> | <b>Due Date</b>     | <b>Discount Amount</b> | <b>Payable Amount</b> |
| <a href="#">S1235125.001</a>      | Powergrip Chain                            |  | 10/01/2025          | 10/31/2025          | 0.00                   | -1,596.16             |
| <a href="#">S1236066.001</a>      | Valve Key Wrench                           |  | 10/28/2025          | 11/27/2025          | 0.00                   | 149.95                |
| <a href="#">S1236607.001</a>      | Meter Insulation                           |  | 11/05/2025          | 12/05/2025          | 0.00                   | 798.00                |
| <a href="#">S1240097.001</a>      | Chain Saw                                  |  | 02/06/2026          | 03/08/2026          | 0.00                   | 4,484.03              |
| <a href="#">022400</a>            | Sherwin Williams                           |  |                     |                     |                        | 215.88                |
| <b>Payment Type</b>               | <b>Payment Number</b>                      |  |                     | <b>Payment Date</b> |                        | <b>Payment Amount</b> |
| EFT                               | <a href="#">9413</a>                       |  |                     | 03/13/2026          |                        | 215.88                |
| <b>Payable Number</b>             | <b>Description</b>                         |  | <b>Payable Date</b> | <b>Due Date</b>     | <b>Discount Amount</b> | <b>Payable Amount</b> |
| <a href="#">76295111661125 CM</a> | Duplicate payment                          |  | 11/25/2025          | 12/25/2025          | 0.00                   | -52.10                |

**Payment Register**

**APPKT01868 - 3/13/2026 AP**

|                            |   |                     |                       |                        |                       |                            |  |
|----------------------------|---|---------------------|-----------------------|------------------------|-----------------------|----------------------------|--|
| <a href="#">9669-9</a>     | Blue paint  | 03/03/2026          | 04/02/2026            | 0.00                   | 267.98                |                            |  |
| <b>Vendor Number</b>       | <b>Vendor Name</b>                                |                     |                       |                        |                       | <b>Total Vendor Amount</b> |  |
| <a href="#">037289</a>     | Texas Dps   |                     |                       |                        |                       | 10.00                      |  |
| <b>Payment Type</b>        | <b>Payment Number</b>                             | <b>Payment Date</b> | <b>Payment Amount</b> |                        |                       |                            |  |
| Check                      | <a href="#">80863</a>                             | 03/13/2026          | 10.00                 |                        |                       |                            |  |
| <b>Payable Number</b>      | <b>Description</b>                                | <b>Payable Date</b> | <b>Due Date</b>       | <b>Discount Amount</b> | <b>Payable Amount</b> |                            |  |
| <a href="#">INV0005112</a> | Certified driving record                          | 03/11/2026          | 04/10/2026            | 0.00                   | 10.00                 |                            |  |
| <b>Vendor Number</b>       | <b>Vendor Name</b>                                |                     |                       |                        |                       | <b>Total Vendor Amount</b> |  |
| <a href="#">038351</a>     | Vickrey Leadership Solutions LLC                  |                     |                       |                        |                       | 7,500.00                   |  |
| <b>Payment Type</b>        | <b>Payment Number</b>                             | <b>Payment Date</b> | <b>Payment Amount</b> |                        |                       |                            |  |
| EFT                        | <a href="#">9414</a>                              | 03/13/2026          | 7,500.00              |                        |                       |                            |  |
| <b>Payable Number</b>      | <b>Description</b>                                | <b>Payable Date</b> | <b>Due Date</b>       | <b>Discount Amount</b> | <b>Payable Amount</b> |                            |  |
| <a href="#">1037</a>       | Vickrey Leadership Solutions - Strategic Plan     | 03/10/2026          | 03/10/2026            | 0.00                   | 7,500.00              |                            |  |
| <b>Vendor Number</b>       | <b>Vendor Name</b>                                |                     |                       |                        |                       | <b>Total Vendor Amount</b> |  |
| <a href="#">034817</a>     | Washer Specialties Co                             |                     |                       |                        |                       | 104.75                     |  |
| <b>Payment Type</b>        | <b>Payment Number</b>                             | <b>Payment Date</b> | <b>Payment Amount</b> |                        |                       |                            |  |
| EFT                        | <a href="#">9415</a>                              | 03/13/2026          | 104.75                |                        |                       |                            |  |
| <b>Payable Number</b>      | <b>Description</b>                                | <b>Payable Date</b> | <b>Due Date</b>       | <b>Discount Amount</b> | <b>Payable Amount</b> |                            |  |
| <a href="#">21079547</a>   | Control Board                                     | 03/09/2026          | 04/08/2026            | 0.00                   | 104.75                |                            |  |
| <b>Vendor Number</b>       | <b>Vendor Name</b>                                |                     |                       |                        |                       | <b>Total Vendor Amount</b> |  |
| <a href="#">037921</a>     | Water Resource Solutions                          |                     |                       |                        |                       | 3,423.13                   |  |
| <b>Payment Type</b>        | <b>Payment Number</b>                             | <b>Payment Date</b> | <b>Payment Amount</b> |                        |                       |                            |  |
| EFT                        | <a href="#">9416</a>                              | 03/13/2026          | 3,423.13              |                        |                       |                            |  |
| <b>Payable Number</b>      | <b>Description</b>                                | <b>Payable Date</b> | <b>Due Date</b>       | <b>Discount Amount</b> | <b>Payable Amount</b> |                            |  |
| <a href="#">2025013-10</a> | Verdigris River Low Water Dam Inspection Contract | 03/03/2026          | 04/02/2026            | 0.00                   | 3,423.13              |                            |  |
| <b>Vendor Number</b>       | <b>Vendor Name</b>                                |                     |                       |                        |                       | <b>Total Vendor Amount</b> |  |
| <a href="#">035913</a>     | Waters Hardware                                   |                     |                       |                        |                       | 743.78                     |  |
| <b>Payment Type</b>        | <b>Payment Number</b>                             | <b>Payment Date</b> | <b>Payment Amount</b> |                        |                       |                            |  |
| EFT                        | <a href="#">9417</a>                              | 03/13/2026          | 743.78                |                        |                       |                            |  |
| <b>Payable Number</b>      | <b>Description</b>                                | <b>Payable Date</b> | <b>Due Date</b>       | <b>Discount Amount</b> | <b>Payable Amount</b> |                            |  |
| <a href="#">8110/P</a>     | Cust no 72177 - Painting tools and shovels        | 01/28/2026          | 02/27/2026            | 0.00                   | 173.92                |                            |  |
| <a href="#">8148/P</a>     | Cust no 72177 - Square Tubing and wire brushes    | 01/30/2026          | 03/01/2026            | 0.00                   | 102.95                |                            |  |
| <a href="#">8226/P</a>     | Cust no 72177 - Pipe Fittings and Screws          | 02/04/2026          | 03/06/2026            | 0.00                   | 98.70                 |                            |  |
| <a href="#">8270/P</a>     | Cust no 72177 - Hex Washers                       | 02/09/2026          | 03/11/2026            | 0.00                   | 32.99                 |                            |  |
| <a href="#">8331/P</a>     | Cust no 72177 - Libman Floor Scrubber             | 02/11/2026          | 03/13/2026            | 0.00                   | 27.98                 |                            |  |
| <a href="#">8364/P</a>     | Cust no 72177 - Grinder Pump Fittings             | 02/13/2026          | 03/15/2026            | 0.00                   | 116.57                |                            |  |
| <a href="#">8366/P</a>     | Cust no 72177 - Pipe Fittings                     | 02/13/2026          | 03/15/2026            | 0.00                   | 104.16                |                            |  |
| <a href="#">8531/P</a>     | Cust no 72177 - Spray Paint                       | 02/25/2026          | 03/27/2026            | 0.00                   | 7.99                  |                            |  |
| <a href="#">8539/P</a>     | Cust no 72180 - Spray for Trees                   | 02/26/2026          | 03/28/2026            | 0.00                   | 26.99                 |                            |  |
| <a href="#">8571/P</a>     | Cust no 72177 - Pipe Adapters                     | 03/02/2026          | 04/01/2026            | 0.00                   | 33.54                 |                            |  |
| <a href="#">8579/P</a>     | cUST NO 72177 - Bar/Chain Oil                     | 03/02/2026          | 04/01/2026            | 0.00                   | 17.99                 |                            |  |
| <b>Vendor Number</b>       | <b>Vendor Name</b>                                |                     |                       |                        |                       | <b>Total Vendor Amount</b> |  |
| <a href="#">034744</a>     | Woods Lumber Company                              |                     |                       |                        |                       | 784.03                     |  |
| <b>Payment Type</b>        | <b>Payment Number</b>                             | <b>Payment Date</b> | <b>Payment Amount</b> |                        |                       |                            |  |
| EFT                        | <a href="#">9418</a>                              | 03/13/2026          | 784.03                |                        |                       |                            |  |
| <b>Payable Number</b>      | <b>Description</b>                                | <b>Payable Date</b> | <b>Due Date</b>       | <b>Discount Amount</b> | <b>Payable Amount</b> |                            |  |
| <a href="#">621081</a>     | Trencher/Trailer Rental                           | 10/28/2025          | 11/27/2025            | 0.00                   | 218.00                |                            |  |
| <a href="#">622083</a>     | PVC Piping  | 11/05/2025          | 12/05/2025            | 0.00                   | 46.56                 |                            |  |
| <a href="#">630676</a>     | Spray Paint                                       | 01/30/2026          | 03/01/2026            | 0.00                   | 76.16                 |                            |  |
| <a href="#">631618</a>     | Lumber  | 02/09/2026          | 03/11/2026            | 0.00                   | 258.02                |                            |  |
| <a href="#">631872</a>     | Leakstop  | 02/11/2026          | 03/13/2026            | 0.00                   | 22.99                 |                            |  |
| <a href="#">632946</a>     | PVC Pipe  | 02/23/2026          | 03/25/2026            | 0.00                   | 11.86                 |                            |  |
| <a href="#">633394</a>     | Safety Fencing                                    | 02/26/2026          | 03/28/2026            | 0.00                   | 37.99                 |                            |  |
| <a href="#">633483</a>     | Paint and Painting Supplies                       | 02/27/2026          | 03/29/2026            | 0.00                   | 59.98                 |                            |  |
| <a href="#">633913</a>     | File Mill/Spout Diverter                          | 03/03/2026          | 04/02/2026            | 0.00                   | 52.47                 |                            |  |

**Payment Register**

**APPKT01868 - 3/13/2026 AP**

|  |  |                                   |                               |                                   |  |                                      |
|--|--|-----------------------------------|-------------------------------|-----------------------------------|--|--------------------------------------|
| <b>Vendor Number</b><br><a href="#">037953</a>     | <b>Vendor Name</b><br>Worksteps, Inc           |                                   |                               |                                   |  | <b>Total Vendor Amount</b><br>150.00 |
| <b>Payment Type</b><br>Check                       | <b>Payment Number</b><br><a href="#">80864</a> |                                   |                               | <b>Payment Date</b><br>03/13/2026 |  | <b>Payment Amount</b><br>150.00      |
| <b>Payable Number</b><br><a href="#">WSC-14697</a> | <b>Description</b><br>POET Testing Police Dept | <b>Payable Date</b><br>02/28/2026 | <b>Due Date</b><br>03/30/2026 | <b>Discount Amount</b><br>0.00    |  | <b>Payable Amount</b><br>150.00      |

|  |   |                                   |                               |                                   |  |  |
|--|---|-----------------------------------|-------------------------------|-----------------------------------|--|--|
| <b>Vendor Number</b><br><a href="#">037036</a> | <b>Vendor Name</b><br>Zinser Electric LLC                               |                                   |                               |                                   |  | <b>Total Vendor Amount</b><br>5,535.00 |
| <b>Payment Type</b><br>EFT                     | <b>Payment Number</b><br><a href="#">9419</a>                           |                                   |                               | <b>Payment Date</b><br>03/13/2026 |  | <b>Payment Amount</b><br>5,535.00      |
| <b>Payable Number</b><br><a href="#">3176</a>  | <b>Description</b><br>Final half payment for WWTP hardware installation | <b>Payable Date</b><br>03/08/2026 | <b>Due Date</b><br>04/07/2026 | <b>Discount Amount</b><br>0.00    |  | <b>Payable Amount</b><br>4,360.00      |
| <a href="#">3177</a>                           | WWTP Burgler alarm/Smoke Detector installation                          | 03/08/2026                        | 04/07/2026                    | 0.00                              |  | 1,125.00                               |
| <a href="#">3178</a>                           | WWTP Monitoring Service   | 03/08/2026                        | 04/07/2026                    | 0.00                              |  | 50.00                                  |

**Payment Summary**

| Bank Code             | Type              | Payable<br>Count | Payment<br>Count | Discount    | Payment             |
|-----------------------|-------------------|------------------|------------------|-------------|---------------------|
| General               | Check             | 46               | 21               | 0.00        | 54,452.82           |
| General               | EFT               | 4                | 2                | 0.00        | 95,223.00           |
| General               | Voided **Void EFT | 0                | 1                | 0.00        | 0.00                |
| General               | EFT               | 75               | 32               | 0.00        | 1,194,997.06        |
| General               | Voided **Void EFT | 0                | 1                | 0.00        | 0.00                |
| General               | EFT               | 9                | 3                | 0.00        | 6,314.71            |
| General               | Voided **Void EFT | 0                | 1                | 0.00        | 0.00                |
| <b>Packet Totals:</b> |                   | <b>134</b>       | <b>61</b>        | <b>0.00</b> | <b>1,350,987.59</b> |

### Cash Fund Summary

| Fund                  | Name        | Amount               |
|-----------------------|-------------|----------------------|
| 099                   | Pooled Cash | -1,350,987.59        |
| <b>Packet Totals:</b> |             | <u>-1,350,987.59</u> |

**APPROPRIATIONS 2026**

Accounts payable paid from March 16th, 2026, through March 31st, 2026.

Total: \$1,005,905.76



City of Independence

# Payment Register

APPKT01892 - 3/17/2026 AP  
01 - City of Independence

**Bank:** General - Community National Bank

| Vendor Number              | Vendor Name                       |              |                | Total Vendor Amount            |
|----------------------------|-----------------------------------|--------------|----------------|--------------------------------|
| <a href="#">038095</a>     | Montgomery County Auto Tag Office |              |                | 10.00                          |
| Payment Type               | Payment Number                    | Payment Date | Payment Amount |                                |
| Check                      | <a href="#">80865</a>             | 03/17/2026   | 10.00          |                                |
| Payable Number             | Description                       | Payable Date | Due Date       | Discount Amount Payable Amount |
| <a href="#">INV0005169</a> | Replacement title - Old 501       | 03/17/2026   | 04/16/2026     | 0.00 10.00                     |

### Payment Summary

| Bank Code             | Type  | Payable<br>Count | Payment<br>Count | Discount    | Payment      |
|-----------------------|-------|------------------|------------------|-------------|--------------|
| General               | Check | 1                | 1                | 0.00        | 10.00        |
| <b>Packet Totals:</b> |       | <b>1</b>         | <b>1</b>         | <b>0.00</b> | <b>10.00</b> |

### Cash Fund Summary

| Fund                  | Name        | Amount        |
|-----------------------|-------------|---------------|
| 099                   | Pooled Cash | -10.00        |
| <b>Packet Totals:</b> |             | <b>-10.00</b> |



Bank: General - Community National Bank

| Vendor Number                                       | Vendor Name                            |                     |                 |                        |                       |                       | Total Vendor Amount        |
|---|--|---------------------|-----------------|------------------------|-----------------------|-----------------------|----------------------------|
|   | **Void**                               |                     |                 |                        |                       |                       | 0.00                       |
| <b>Payment Type</b>                                 | <b>Payment Number</b>                  |                     |                 | <b>Payment Date</b>    |                       | <b>Payment Amount</b> |                            |
| **Void EFT  | <a href="#">9435</a>                   |                     |                 | 03/20/2026             |                       | 0.00                  |                            |
| <b>Payable Number</b>                               | <b>Description</b>                     | <b>Payable Date</b> | <b>Due Date</b> | <b>Discount Amount</b> | <b>Payable Amount</b> |                       |                            |
|   |  |                     |                 | 0.00                   | 0.00                  |                       |                            |
|   | **Void EFT                             |                     |                 |                        |                       |                       | 0.00                       |
| <b>Payment Type</b>                                 | <b>Payment Number</b>                  |                     |                 | <b>Payment Date</b>    |                       | <b>Payment Amount</b> |                            |
| **Void EFT  | <a href="#">9436</a>                   |                     |                 | 03/20/2026             |                       | 0.00                  |                            |
| <b>Payable Number</b>                               | <b>Description</b>                     | <b>Payable Date</b> | <b>Due Date</b> | <b>Discount Amount</b> | <b>Payable Amount</b> |                       |                            |
|   |  |                     |                 | 0.00                   | 0.00                  |                       |                            |
|   | **Void EFT                             |                     |                 |                        |                       |                       | 0.00                       |
| <b>Payment Type</b>                                 | <b>Payment Number</b>                  |                     |                 | <b>Payment Date</b>    |                       | <b>Payment Amount</b> |                            |
| **Void EFT  | <a href="#">9454</a>                   |                     |                 | 03/20/2026             |                       | 0.00                  |                            |
| <b>Payable Number</b>                               | <b>Description</b>                     | <b>Payable Date</b> | <b>Due Date</b> | <b>Discount Amount</b> | <b>Payable Amount</b> |                       |                            |
|   |  |                     |                 | 0.00                   | 0.00                  |                       |                            |
|   | **Void EFT                             |                     |                 |                        |                       |                       | 0.00                       |
| <b>Payment Type</b>                                 | <b>Payment Number</b>                  |                     |                 | <b>Payment Date</b>    |                       | <b>Payment Amount</b> |                            |
| **Void EFT  | <a href="#">9456</a>                   |                     |                 | 03/20/2026             |                       | 0.00                  |                            |
| <b>Payable Number</b>                               | <b>Description</b>                     | <b>Payable Date</b> | <b>Due Date</b> | <b>Discount Amount</b> | <b>Payable Amount</b> |                       |                            |
|   |  |                     |                 | 0.00                   | 0.00                  |                       |                            |
| <b>Vendor Number</b>                                | <b>Vendor Name</b>                     |                     |                 |                        |                       |                       | <b>Total Vendor Amount</b> |
| <a href="#">038236</a>                              | Ace Transports LLC                     |                     |                 |                        |                       |                       | 4,314.98                   |
| <b>Payment Type</b>                                 | <b>Payment Number</b>                  |                     |                 | <b>Payment Date</b>    |                       | <b>Payment Amount</b> |                            |
| EFT   | <a href="#">9420</a>                   |                     |                 | 03/20/2026             |                       | 4,314.98              |                            |
| <b>Payable Number</b>                               | <b>Description</b>                     | <b>Payable Date</b> | <b>Due Date</b> | <b>Discount Amount</b> | <b>Payable Amount</b> |                       |                            |
| <a href="#">INV-183</a>                             | 603 Repair                             | 03/12/2026          | 04/11/2026      | 0.00                   | 4,314.98              |                       |                            |
| <b>Vendor Number</b>                                | <b>Vendor Name</b>                     |                     |                 |                        |                       |                       | <b>Total Vendor Amount</b> |
| <a href="#">035900</a>                              | Ane Mae's Coffee And Sandwich Shop     |                     |                 |                        |                       |                       | 348.80                     |
| <b>Payment Type</b>                                 | <b>Payment Number</b>                  |                     |                 | <b>Payment Date</b>    |                       | <b>Payment Amount</b> |                            |
| EFT   | <a href="#">9421</a>                   |                     |                 | 03/20/2026             |                       | 348.80                |                            |
| <b>Payable Number</b>                               | <b>Description</b>                     | <b>Payable Date</b> | <b>Due Date</b> | <b>Discount Amount</b> | <b>Payable Amount</b> |                       |                            |
| <a href="#">13283</a>                               | Strategic Plan                         | 03/11/2026          | 04/10/2026      | 0.00                   | 348.80                |                       |                            |
| <b>Vendor Number</b>                                | <b>Vendor Name</b>                     |                     |                 |                        |                       |                       | <b>Total Vendor Amount</b> |
| <a href="#">038287</a>                              | Ashcraft Tire & Auto                   |                     |                 |                        |                       |                       | 583.26                     |
| <b>Payment Type</b>                                 | <b>Payment Number</b>                  |                     |                 | <b>Payment Date</b>    |                       | <b>Payment Amount</b> |                            |
| EFT   | <a href="#">9422</a>                   |                     |                 | 03/20/2026             |                       | 583.26                |                            |
| <b>Payable Number</b>                               | <b>Description</b>                     | <b>Payable Date</b> | <b>Due Date</b> | <b>Discount Amount</b> | <b>Payable Amount</b> |                       |                            |
| <a href="#">052034</a>                              | Mustang Jet Truck Servicing            | 03/10/2026          | 04/09/2026      | 0.00                   | 583.26                |                       |                            |
| <b>Vendor Number</b>                                | <b>Vendor Name</b>                     |                     |                 |                        |                       |                       | <b>Total Vendor Amount</b> |
| <a href="#">036623</a>                              | AT&T                                   |                     |                 |                        |                       |                       | 1,304.03                   |
| <b>Payment Type</b>                                 | <b>Payment Number</b>                  |                     |                 | <b>Payment Date</b>    |                       | <b>Payment Amount</b> |                            |
| Check   | <a href="#">80866</a>                  |                     |                 | 03/20/2026             |                       | 1,304.03              |                            |
| <b>Payable Number</b>                               | <b>Description</b>                     | <b>Payable Date</b> | <b>Due Date</b> | <b>Discount Amount</b> | <b>Payable Amount</b> |                       |                            |
| <a href="#">5003233111</a>                          | Acct #831-001-4887-638 - Memorial Hall | 03/07/2026          | 04/06/2026      | 0.00                   | 1,304.03              |                       |                            |
| <b>Vendor Number</b>                                | <b>Vendor Name</b>                     |                     |                 |                        |                       |                       | <b>Total Vendor Amount</b> |
| <a href="#">037944</a>                              | Atmos                                  |                     |                 |                        |                       |                       | 102.30                     |
| <b>Payment Type</b>                                 | <b>Payment Number</b>                  |                     |                 | <b>Payment Date</b>    |                       | <b>Payment Amount</b> |                            |
| Check   | <a href="#">80867</a>                  |                     |                 | 03/20/2026             |                       | 102.30                |                            |
| <b>Payable Number</b>                               | <b>Description</b>                     | <b>Payable Date</b> | <b>Due Date</b> | <b>Discount Amount</b> | <b>Payable Amount</b> |                       |                            |
| <a href="#">3049632850</a> <a href="#">Mar 2026</a> | Acct #3049632850 - 1009 E Cedar Unit C | 03/10/2026          | 04/09/2026      | 0.00                   | 36.18                 |                       |                            |
| <a href="#">3074273898</a> <a href="#">Mar 2026</a> | Cust #3074273898122 - East Locust      | 03/02/2026          | 04/01/2026      | 0.00                   | 66.12                 |                       |                            |

**Payment Register**

**APPKT01887 - 3/20/2026 AP**

|  |  |                                   |                               |                                   |                                 |                                      |
|--|--|-----------------------------------|-------------------------------|-----------------------------------|---------------------------------|--------------------------------------|
| <b>Vendor Number</b><br><a href="#">037126</a>       | <b>Vendor Name</b><br>Autozone, Inc            |                                   |                               |                                   |                                 | <b>Total Vendor Amount</b><br>235.62 |
| <b>Payment Type</b><br>Check                         | <b>Payment Number</b><br><a href="#">80868</a> |                                   |                               | <b>Payment Date</b><br>03/20/2026 | <b>Payment Amount</b><br>235.62 |                                      |
| <b>Payable Number</b><br><a href="#">01605669099</a> | <b>Description</b><br>CPSC mower maint         | <b>Payable Date</b><br>03/10/2026 | <b>Due Date</b><br>04/09/2026 | <b>Discount Amount</b><br>0.00    | <b>Payable Amount</b><br>72.41  |                                      |
| <a href="#">01605669111</a>                          | battery return                                 | 03/10/2026                        | 04/09/2026                    | 0.00                              | -69.06                          |                                      |
| <a href="#">01605669112</a>                          | CPSC mower repair                              | 03/10/2026                        | 04/09/2026                    | 0.00                              | 170.93                          |                                      |
| <a href="#">01605669393</a>                          | 5 gallon gas can                               | 03/10/2026                        | 04/09/2026                    | 0.00                              | 22.87                           |                                      |
| <a href="#">01605669929</a>                          | batteries and wrench                           | 03/12/2026                        | 04/11/2026                    | 0.00                              | 38.47                           |                                      |

|   |  |                                   |                               |                                   |                                   |  |
|---|--|-----------------------------------|-------------------------------|-----------------------------------|-----------------------------------|--|
| <b>Vendor Number</b><br><a href="#">037925</a>  | <b>Vendor Name</b><br>Bartlett Cooperative Association |                                   |                               |                                   |                                   | <b>Total Vendor Amount</b><br>2,772.65 |
| <b>Payment Type</b><br>Check                    | <b>Payment Number</b><br><a href="#">80869</a>         |                                   |                               | <b>Payment Date</b><br>03/20/2026 | <b>Payment Amount</b><br>2,772.65 |  |
| <b>Payable Number</b><br><a href="#">634226</a> | <b>Description</b><br>Diesel                           | <b>Payable Date</b><br>03/06/2026 | <b>Due Date</b><br>04/05/2026 | <b>Discount Amount</b><br>0.00    | <b>Payable Amount</b><br>2,772.65 |  |

|   |  |                                   |                               |                                   |                                     |  |
|---|--|-----------------------------------|-------------------------------|-----------------------------------|-------------------------------------|--|
| <b>Vendor Number</b><br><a href="#">038326</a>                      | <b>Vendor Name</b><br>BCI Mechanical Inc                               |                                   |                               |                                   |                                     | <b>Total Vendor Amount</b><br>113,038.20 |
| <b>Payment Type</b><br>EFT  | <b>Payment Number</b><br><a href="#">9423</a>                          |                                   |                               | <b>Payment Date</b><br>03/20/2026 | <b>Payment Amount</b><br>113,038.20 |  |
| <b>Payable Number</b><br><a href="#">IMH Chiller Replacement Pa</a> | <b>Description</b><br>Memorial Hall Chiller & Water Heater Replacement | <b>Payable Date</b><br>02/20/2026 | <b>Due Date</b><br>02/20/2026 | <b>Discount Amount</b><br>0.00    | <b>Payable Amount</b><br>113,038.20 |  |

|  |   |                                   |                               |                                   |                                   |  |
|--|---|-----------------------------------|-------------------------------|-----------------------------------|-----------------------------------|--|
| <b>Vendor Number</b><br><a href="#">035073</a> | <b>Vendor Name</b><br>Blankinship Electric, LLC |                                   |                               |                                   |                                   | <b>Total Vendor Amount</b><br>2,895.25 |
| <b>Payment Type</b><br>Check                   | <b>Payment Number</b><br><a href="#">80870</a>  |                                   |                               | <b>Payment Date</b><br>03/20/2026 | <b>Payment Amount</b><br>2,895.25 |  |
| <b>Payable Number</b><br><a href="#">4151</a>  | <b>Description</b><br>Storm Siren Repair        | <b>Payable Date</b><br>01/15/2026 | <b>Due Date</b><br>02/14/2026 | <b>Discount Amount</b><br>0.00    | <b>Payable Amount</b><br>2,895.25 |  |

|   |  |                                   |                               |                                   |                                 |                                      |
|---|--|-----------------------------------|-------------------------------|-----------------------------------|---------------------------------|--------------------------------------|
| <b>Vendor Number</b><br><a href="#">033027</a>      | <b>Vendor Name</b><br>Cintas Corporation         |                                   |                               |                                   |                                 | <b>Total Vendor Amount</b><br>633.47 |
| <b>Payment Type</b><br>EFT                          | <b>Payment Number</b><br><a href="#">9424</a>    |                                   |                               | <b>Payment Date</b><br>03/20/2026 | <b>Payment Amount</b><br>633.47 |                                      |
| <b>Payable Number</b><br><a href="#">5318899305</a> | <b>Description</b><br>Airport first aid supplies | <b>Payable Date</b><br>02/17/2026 | <b>Due Date</b><br>03/19/2026 | <b>Discount Amount</b><br>0.00    | <b>Payable Amount</b><br>50.50  |                                      |
| <a href="#">5322995102</a>                          | WTP First Aid Supplies                           | 03/11/2026                        | 04/10/2026                    | 0.00                              | 47.10                           |                                      |
| <a href="#">5322995103</a>                          | WTP First Aid Supplies                           | 03/11/2026                        | 04/10/2026                    | 0.00                              | 20.68                           |                                      |
| <a href="#">5322995104</a>                          | Cleaning supplies                                | 03/11/2026                        | 04/10/2026                    | 0.00                              | 10.53                           |                                      |
| <a href="#">5322995107</a>                          | Sanitation First Aid                             | 03/11/2026                        | 04/10/2026                    | 0.00                              | 295.86                          |                                      |
| <a href="#">9361725013</a>                          | Water/Sewer First Aid Supplies                   | 02/28/2026                        | 03/30/2026                    | 0.00                              | 208.80                          |                                      |

|  |   |                                   |                               |                                   |                                |                                     |
|--|---|-----------------------------------|-------------------------------|-----------------------------------|--------------------------------|-------------------------------------|
| <b>Vendor Number</b><br><a href="#">032159</a> | <b>Vendor Name</b><br>CJ'S Threads            |                                   |                               |                                   |                                | <b>Total Vendor Amount</b><br>39.91 |
| <b>Payment Type</b><br>EFT                     | <b>Payment Number</b><br><a href="#">9425</a> |                                   |                               | <b>Payment Date</b><br>03/20/2026 | <b>Payment Amount</b><br>39.91 |                                     |
| <b>Payable Number</b><br><a href="#">25726</a> | <b>Description</b><br>scott shirt embroidery  | <b>Payable Date</b><br>03/12/2026 | <b>Due Date</b><br>04/11/2026 | <b>Discount Amount</b><br>0.00    | <b>Payable Amount</b><br>39.91 |                                     |

|   |   |                                   |                               |                                   |                                 |                                      |
|---|---|-----------------------------------|-------------------------------|-----------------------------------|---------------------------------|--------------------------------------|
| <b>Vendor Number</b><br><a href="#">037780</a>    | <b>Vendor Name</b><br>Clean Uniform Company   |                                   |                               |                                   |                                 | <b>Total Vendor Amount</b><br>437.36 |
| <b>Payment Type</b><br>EFT                        | <b>Payment Number</b><br><a href="#">9426</a> |                                   |                               | <b>Payment Date</b><br>03/20/2026 | <b>Payment Amount</b><br>437.36 |                                      |
| <b>Payable Number</b><br><a href="#">22340199</a> | <b>Description</b><br>Uniform Cleaning        | <b>Payable Date</b><br>02/10/2026 | <b>Due Date</b><br>03/12/2026 | <b>Discount Amount</b><br>0.00    | <b>Payable Amount</b><br>58.40  |                                      |
| <a href="#">22341994</a>                          | Uniform Cleaning                              | 02/17/2026                        | 03/19/2026                    | 0.00                              | 70.80                           |                                      |
| <a href="#">22343806</a>                          | Uniform Cleaning                              | 02/24/2026                        | 03/26/2026                    | 0.00                              | 99.76                           |                                      |
| <a href="#">22345604</a>                          | Uniform Cleaning                              | 03/03/2026                        | 04/02/2026                    | 0.00                              | 104.68                          |                                      |
| <a href="#">22347431</a>                          | Uniform Cleaning                              | 03/10/2026                        | 04/09/2026                    | 0.00                              | 103.72                          |                                      |

Payment Register

APPKT01887 - 3/20/2026 AP

|   |   |                                   |                               |                                   |  |                                     |
|---|---|-----------------------------------|-------------------------------|-----------------------------------|--|-------------------------------------|
| <b>Vendor Number</b><br><a href="#">036822</a>  | <b>Vendor Name</b><br>Copy Products Inc       |                                   |                               |                                   |  | <b>Total Vendor Amount</b><br>33.39 |
| <b>Payment Type</b><br>EFT                      | <b>Payment Number</b><br><a href="#">9427</a> |                                   |                               | <b>Payment Date</b><br>03/20/2026 |  | <b>Payment Amount</b><br>33.39      |
| <b>Payable Number</b><br><a href="#">580559</a> | <b>Description</b><br>Waste Toner             | <b>Payable Date</b><br>03/13/2026 | <b>Due Date</b><br>04/12/2026 | <b>Discount Amount</b><br>0.00    |  | <b>Payable Amount</b><br>33.39      |

|  |   |                                   |                               |                                   |  |  |
|--|---|-----------------------------------|-------------------------------|-----------------------------------|--|--|
| <b>Vendor Number</b><br><a href="#">032078</a> | <b>Vendor Name</b><br>CPR Pest Management, Inc. |                                   |                               |                                   |  | <b>Total Vendor Amount</b><br>3,085.00 |
| <b>Payment Type</b><br>EFT                     | <b>Payment Number</b><br><a href="#">9428</a>   |                                   |                               | <b>Payment Date</b><br>03/20/2026 |  | <b>Payment Amount</b><br>3,085.00      |
| <b>Payable Number</b><br><a href="#">48510</a> | <b>Description</b><br>PT Unit 310               | <b>Payable Date</b><br>10/13/2025 | <b>Due Date</b><br>12/31/2025 | <b>Discount Amount</b><br>0.00    |  | <b>Payable Amount</b><br>800.00        |
| <a href="#">48511</a>                          | PT Unit 316                                     | 10/13/2025                        | 12/31/2025                    | 0.00                              |  | 800.00                                 |
| <a href="#">48842</a>                          | 1009 Unit A                                     | 11/07/2025                        | 12/31/2025                    | 0.00                              |  | 700.00                                 |
| <a href="#">49022</a>                          | PT Unit 311                                     | 11/20/2025                        | 12/31/2025                    | 0.00                              |  | 700.00                                 |
| <a href="#">50169</a>                          | Monthly Pest Control Service                    | 02/27/2026                        | 03/29/2026                    | 0.00                              |  | 85.00                                  |

|  |   |                                   |                               |                                   |  |   |
|--|---|-----------------------------------|-------------------------------|-----------------------------------|--|---|
| <b>Vendor Number</b><br><a href="#">035070</a> | <b>Vendor Name</b><br>D&F Services, LLC       |                                   |                               |                                   |  | <b>Total Vendor Amount</b><br>14,619.30 |
| <b>Payment Type</b><br>EFT                     | <b>Payment Number</b><br><a href="#">9429</a> |                                   |                               | <b>Payment Date</b><br>03/20/2026 |  | <b>Payment Amount</b><br>14,619.30      |
| <b>Payable Number</b><br><a href="#">7636</a>  | <b>Description</b><br>Sodium Chlorite         | <b>Payable Date</b><br>03/03/2026 | <b>Due Date</b><br>04/02/2026 | <b>Discount Amount</b><br>0.00    |  | <b>Payable Amount</b><br>11,769.30      |
| <a href="#">7639</a>                           | DFLOC   | 03/05/2026                        | 04/04/2026                    | 0.00                              |  | 2,850.00                                |

|  |   |                                   |                               |                                   |  |  |
|--|---|-----------------------------------|-------------------------------|-----------------------------------|--|--|
| <b>Vendor Number</b><br><a href="#">006320</a>     | <b>Vendor Name</b><br>Decker Construction, Inc.               |                                   |                               |                                   |  | <b>Total Vendor Amount</b><br>195,515.55 |
| <b>Payment Type</b><br>EFT                         | <b>Payment Number</b><br><a href="#">9430</a>                 |                                   |                               | <b>Payment Date</b><br>03/20/2026 |  | <b>Payment Amount</b><br>195,515.55      |
| <b>Payable Number</b><br><a href="#">DRAW00009</a> | <b>Description</b><br>Jefferson Subdivision Home Construction | <b>Payable Date</b><br>02/27/2026 | <b>Due Date</b><br>03/29/2026 | <b>Discount Amount</b><br>0.00    |  | <b>Payable Amount</b><br>195,515.55      |

|  |   |                                   |                               |                                   |  |  |
|--|---|-----------------------------------|-------------------------------|-----------------------------------|--|--|
| <b>Vendor Number</b><br><a href="#">007200</a> | <b>Vendor Name</b><br>Eric's Plumbing               |                                   |                               |                                   |  | <b>Total Vendor Amount</b><br>4,000.00 |
| <b>Payment Type</b><br>EFT                     | <b>Payment Number</b><br><a href="#">9431</a>       |                                   |                               | <b>Payment Date</b><br>03/20/2026 |  | <b>Payment Amount</b><br>4,000.00      |
| <b>Payable Number</b><br><a href="#">5320</a>  | <b>Description</b><br>415 S. 14th sewer replacement | <b>Payable Date</b><br>03/09/2026 | <b>Due Date</b><br>04/08/2026 | <b>Discount Amount</b><br>0.00    |  | <b>Payable Amount</b><br>2,000.00      |
| <a href="#">5321</a>                           | 421 S. 14th sewer replacement                       | 03/09/2026                        | 04/08/2026                    | 0.00                              |  | 2,000.00                               |

|  |  |                                   |                               |                                   |  |                                      |
|--|--|-----------------------------------|-------------------------------|-----------------------------------|--|--------------------------------------|
| <b>Vendor Number</b><br><a href="#">037979</a>               | <b>Vendor Name</b><br>Everygy                        |                                   |                               |                                   |  | <b>Total Vendor Amount</b><br>325.12 |
| <b>Payment Type</b><br>Check                                 | <b>Payment Number</b><br><a href="#">80871</a>       |                                   |                               | <b>Payment Date</b><br>03/20/2026 |  | <b>Payment Amount</b><br>325.12      |
| <b>Payable Number</b><br><a href="#">0055851536 Feb 2026</a> | <b>Description</b><br>Acct #0055851536 - 600 Catalpa | <b>Payable Date</b><br>03/11/2026 | <b>Due Date</b><br>03/11/2026 | <b>Discount Amount</b><br>0.00    |  | <b>Payable Amount</b><br>14.22       |
| <a href="#">0264136247 Feb 2026</a>                          | Acct #0264136247 - 512 Catalpa                       | 03/11/2026                        | 03/11/2026                    | 0.00                              |  | 13.97                                |
| <a href="#">1735041215 Feb 2026</a>                          | Acct #1735041215 - 612 Catalpa                       | 03/11/2026                        | 03/11/2026                    | 0.00                              |  | 57.76                                |
| <a href="#">3242453380 - Feb 2026</a>                        | Acct #3242453380 - 500 Catalpa                       | 03/11/2026                        | 03/11/2026                    | 0.00                              |  | 26.66                                |
| <a href="#">6536329777 Feb 2026</a>                          | Acct #6536329777 - 621 Catalpa                       | 03/11/2026                        | 03/11/2026                    | 0.00                              |  | 12.85                                |
| <a href="#">6645979078 Feb 2026</a>                          | Acct #6645979078 - 606 Catalpa                       | 03/11/2026                        | 03/11/2026                    | 0.00                              |  | 58.71                                |
| <a href="#">8526661236 Feb 2026</a>                          | Acct #8526661236 - 617 Catalpa                       | 03/11/2026                        | 03/11/2026                    | 0.00                              |  | 15.44                                |
| <a href="#">9103034205 Feb 2026</a>                          | Acct #9103034205 - 704/408/1009 Unit C               | 02/13/2026                        | 02/13/2026                    | 0.00                              |  | 108.30                               |
| <a href="#">9982921045 Feb 2026</a>                          | Acct #9982921045 - 506 Catalpa                       | 02/27/2026                        | 02/27/2026                    | 0.00                              |  | 17.21                                |

Payment Register

APPKT01887 - 3/20/2026 AP

| Vendor Number              | Vendor Name                     |                     |                 |                        |                       | Total Vendor Amount        |
|----------------------------|---------------------------------|---------------------|-----------------|------------------------|-----------------------|----------------------------|
| <a href="#">035115</a>     | Express Services, Inc.          |                     |                 |                        |                       | 13,391.70                  |
| <b>Payment Type</b>        | <b>Payment Number</b>           |                     |                 | <b>Payment Date</b>    |                       | <b>Payment Amount</b>      |
| EFT                        | <a href="#">9432</a>            |                     |                 | 03/20/2026             |                       | 13,391.70                  |
| <b>Payable Number</b>      | <b>Description</b>              | <b>Payable Date</b> | <b>Due Date</b> | <b>Discount Amount</b> | <b>Payable Amount</b> |                            |
| <a href="#">33613846</a>   | Express Employment              | 03/11/2026          | 04/10/2026      | 0.00                   | 13,391.70             |                            |
| <b>Vendor Number</b>       | <b>Vendor Name</b>              |                     |                 |                        |                       | <b>Total Vendor Amount</b> |
| <a href="#">037383</a>     | Ferguson Enterprises LLC #3325  |                     |                 |                        |                       | 259.08                     |
| <b>Payment Type</b>        | <b>Payment Number</b>           |                     |                 | <b>Payment Date</b>    |                       | <b>Payment Amount</b>      |
| EFT                        | <a href="#">9433</a>            |                     |                 | 03/20/2026             |                       | 259.08                     |
| <b>Payable Number</b>      | <b>Description</b>              | <b>Payable Date</b> | <b>Due Date</b> | <b>Discount Amount</b> | <b>Payable Amount</b> |                            |
| <a href="#">WW079688</a>   | Hand Pump w/ hose               | 12/29/2025          | 01/28/2026      | 0.00                   | 259.08                |                            |
| <b>Vendor Number</b>       | <b>Vendor Name</b>              |                     |                 |                        |                       | <b>Total Vendor Amount</b> |
| <a href="#">037139</a>     | Fleet Fuels, LLC                |                     |                 |                        |                       | 36.48                      |
| <b>Payment Type</b>        | <b>Payment Number</b>           |                     |                 | <b>Payment Date</b>    |                       | <b>Payment Amount</b>      |
| EFT                        | <a href="#">9434</a>            |                     |                 | 03/20/2026             |                       | 36.48                      |
| <b>Payable Number</b>      | <b>Description</b>              | <b>Payable Date</b> | <b>Due Date</b> | <b>Discount Amount</b> | <b>Payable Amount</b> |                            |
| <a href="#">CFSI-49157</a> | Fire/EMS Fuel                   | 03/08/2026          | 04/07/2026      | 0.00                   | -6,772.97             |                            |
| <a href="#">CFSI-49158</a> | Park Dept. Fuel                 | 03/08/2026          | 04/07/2026      | 0.00                   | 151.40                |                            |
| <a href="#">CFSI-49159</a> | Police Fuel                     | 03/08/2026          | 04/07/2026      | 0.00                   | 478.98                |                            |
| <a href="#">CFSI-49160</a> | Sewer Collection Fuel           | 03/08/2026          | 04/07/2026      | 0.00                   | 186.39                |                            |
| <a href="#">CFSI-49161</a> | Street Fuel                     | 03/08/2026          | 04/07/2026      | 0.00                   | 790.59                |                            |
| <a href="#">CFSI-49162</a> | Water Distribution Fuel         | 03/08/2026          | 04/07/2026      | 0.00                   | 157.56                |                            |
| <a href="#">CFSI-49163</a> | Water/Sewer Administration Fuel | 03/13/2026          | 04/12/2026      | 0.00                   | 205.18                |                            |
| <a href="#">CFSI-49164</a> | Sanitation Fuel                 | 03/08/2026          | 04/07/2026      | 0.00                   | 849.46                |                            |
| <a href="#">CFSI-49897</a> | Animal Control Fuel             | 03/15/2026          | 04/14/2026      | 0.00                   | 106.62                |                            |
| <a href="#">CFSI-49898</a> | Fire/EMS Fuel                   | 03/15/2026          | 04/14/2026      | 0.00                   | 671.21                |                            |
| <a href="#">CFSI-49899</a> | Park Dept. Fuel                 | 03/15/2026          | 04/14/2026      | 0.00                   | 49.75                 |                            |
| <a href="#">CFSI-49900</a> | Police Fuel                     | 03/15/2026          | 04/14/2026      | 0.00                   | 701.10                |                            |
| <a href="#">CFSI-49901</a> | Sewer Collection Fuel           | 03/15/2026          | 04/14/2026      | 0.00                   | 159.60                |                            |
| <a href="#">CFSI-49902</a> | Sewer Treatment Fuel            | 03/15/2026          | 04/14/2026      | 0.00                   | 69.72                 |                            |
| <a href="#">CFSI-49903</a> | Street Fuel                     | 03/15/2026          | 04/14/2026      | 0.00                   | 488.93                |                            |
| <a href="#">CFSI-49904</a> | Water Distribution Fuel         | 03/15/2026          | 04/14/2026      | 0.00                   | 279.52                |                            |
| <a href="#">CFSI-49905</a> | Water/Sewer Administration Fuel | 03/15/2026          | 04/14/2026      | 0.00                   | 135.35                |                            |
| <a href="#">CFSI-49906</a> | Sanitation Fuel                 | 03/15/2026          | 04/14/2026      | 0.00                   | 1,018.26              |                            |
| <a href="#">SI-60471</a>   | Fuel                            | 02/11/2026          | 03/13/2026      | 0.00                   | 309.83                |                            |
| <b>Vendor Number</b>       | <b>Vendor Name</b>              |                     |                 |                        |                       | <b>Total Vendor Amount</b> |
| <a href="#">038369</a>     | Formex Holdings, LLC            |                     |                 |                        |                       | 8,288.10                   |
| <b>Payment Type</b>        | <b>Payment Number</b>           |                     |                 | <b>Payment Date</b>    |                       | <b>Payment Amount</b>      |
| Check                      | <a href="#">80872</a>           |                     |                 | 03/20/2026             |                       | 8,288.10                   |
| <b>Payable Number</b>      | <b>Description</b>              | <b>Payable Date</b> | <b>Due Date</b> | <b>Discount Amount</b> | <b>Payable Amount</b> |                            |
| <a href="#">INV-61165</a>  | Poly Carts and Spare Parts      | 03/09/2026          | 03/09/2026      | 0.00                   | 8,288.10              |                            |
| <b>Vendor Number</b>       | <b>Vendor Name</b>              |                     |                 |                        |                       | <b>Total Vendor Amount</b> |
| <a href="#">034052</a>     | Garsite Progress LLC            |                     |                 |                        |                       | 2,782.71                   |
| <b>Payment Type</b>        | <b>Payment Number</b>           |                     |                 | <b>Payment Date</b>    |                       | <b>Payment Amount</b>      |
| EFT                        | <a href="#">9437</a>            |                     |                 | 03/20/2026             |                       | 2,782.71                   |
| <b>Payable Number</b>      | <b>Description</b>              | <b>Payable Date</b> | <b>Due Date</b> | <b>Discount Amount</b> | <b>Payable Amount</b> |                            |
| <a href="#">INV15136</a>   | Jet Bowser Parts                | 11/10/2025          | 12/10/2025      | 0.00                   | 2,782.71              |                            |
| <b>Vendor Number</b>       | <b>Vendor Name</b>              |                     |                 |                        |                       | <b>Total Vendor Amount</b> |
| <a href="#">009330</a>     | Grainger                        |                     |                 |                        |                       | 374.72                     |
| <b>Payment Type</b>        | <b>Payment Number</b>           |                     |                 | <b>Payment Date</b>    |                       | <b>Payment Amount</b>      |
| EFT                        | <a href="#">9438</a>            |                     |                 | 03/20/2026             |                       | 374.72                     |
| <b>Payable Number</b>      | <b>Description</b>              | <b>Payable Date</b> | <b>Due Date</b> | <b>Discount Amount</b> | <b>Payable Amount</b> |                            |
| <a href="#">9831753802</a> | PVC pipe and fittings           | 03/05/2026          | 04/04/2026      | 0.00                   | 374.72                |                            |

Payment Register

APPKT01887 - 3/20/2026 AP

|   |   |                                   |                                   |                                      |                                 |
|---|---|-----------------------------------|-----------------------------------|--------------------------------------|---------------------------------|
| <b>Vendor Number</b><br><a href="#">008200</a>          | <b>Vendor Name</b><br>Harry Bass Attorney             |                                   |                                   | <b>Total Vendor Amount</b><br>800.00 |                                 |
| <b>Payment Type</b><br>Check                            | <b>Payment Number</b><br><a href="#">80873</a>        |                                   | <b>Payment Date</b><br>03/20/2026 | <b>Payment Amount</b><br>800.00      |                                 |
| <b>Payable Number</b><br><a href="#">3/12/2026 Stmt</a> | <b>Description</b><br>Court Appointment Attorney Fees | <b>Payable Date</b><br>03/12/2026 | <b>Due Date</b><br>04/11/2026     | <b>Discount Amount</b><br>0.00       | <b>Payable Amount</b><br>800.00 |

|  |   |                                   |                                   |  |                                   |
|--|---|-----------------------------------|-----------------------------------|--|-----------------------------------|
| <b>Vendor Number</b><br><a href="#">036233</a>   | <b>Vendor Name</b><br>Hawkins Inc.            |                                   |                                   | <b>Total Vendor Amount</b><br>5,379.08 |                                   |
| <b>Payment Type</b><br>EFT                       | <b>Payment Number</b><br><a href="#">9439</a> |                                   | <b>Payment Date</b><br>03/20/2026 | <b>Payment Amount</b><br>5,379.08      |                                   |
| <b>Payable Number</b><br><a href="#">7355283</a> | <b>Description</b><br>Residual Analyzer       | <b>Payable Date</b><br>03/06/2026 | <b>Due Date</b><br>04/05/2026     | <b>Discount Amount</b><br>0.00         | <b>Payable Amount</b><br>5,379.08 |

|  |  |                                   |                                   |                                      |                                 |
|--|--|-----------------------------------|-----------------------------------|--------------------------------------|---------------------------------|
| <b>Vendor Number</b><br><a href="#">010440</a>   | <b>Vendor Name</b><br>Hugo's Industrial Supply |                                   |                                   | <b>Total Vendor Amount</b><br>824.44 |                                 |
| <b>Payment Type</b><br>EFT                       | <b>Payment Number</b><br><a href="#">9440</a>  |                                   | <b>Payment Date</b><br>03/20/2026 | <b>Payment Amount</b><br>824.44      |                                 |
| <b>Payable Number</b><br><a href="#">11034CM</a> | <b>Description</b><br>Wrist rest & mouse pad   | <b>Payable Date</b><br>03/11/2026 | <b>Due Date</b><br>04/10/2026     | <b>Discount Amount</b><br>0.00       | <b>Payable Amount</b><br>-63.79 |
| <a href="#">348271</a>                           | Markers and Trash bags                         | 02/11/2026                        | 03/13/2026                        | 0.00                                 | 80.17                           |
| <a href="#">349040</a>                           | Towels   | 03/02/2026                        | 04/01/2026                        | 0.00                                 | 34.39                           |
| <a href="#">349633</a>                           | cleaning supplies                              | 03/13/2026                        | 04/12/2026                        | 0.00                                 | 651.20                          |
| <a href="#">349692</a>                           | Dust Mop                                       | 03/16/2026                        | 04/15/2026                        | 0.00                                 | 33.94                           |
| <a href="#">349742</a>                           | Laminating pouches                             | 03/17/2026                        | 04/16/2026                        | 0.00                                 | 88.53                           |

|   |  |                                   |                                   |  |                                   |
|---|--|-----------------------------------|-----------------------------------|--|-----------------------------------|
| <b>Vendor Number</b><br><a href="#">038354</a>    | <b>Vendor Name</b><br>Hyspeco, Inc             |                                   |                                   | <b>Total Vendor Amount</b><br>7,273.57 |                                   |
| <b>Payment Type</b><br>Check                      | <b>Payment Number</b><br><a href="#">80874</a> |                                   | <b>Payment Date</b><br>03/20/2026 | <b>Payment Amount</b><br>7,273.57      |                                   |
| <b>Payable Number</b><br><a href="#">00928869</a> | <b>Description</b><br>Pump Parts               | <b>Payable Date</b><br>02/27/2026 | <b>Due Date</b><br>02/27/2026     | <b>Discount Amount</b><br>0.00         | <b>Payable Amount</b><br>6,424.55 |
| <a href="#">00930811</a>                          | Cap and Plug Kits                              | 03/05/2026                        | 03/05/2026                        | 0.00                                   | 849.02                            |

|  |  |                                   |                                   |                                     |                                |
|--|--|-----------------------------------|-----------------------------------|-------------------------------------|--------------------------------|
| <b>Vendor Number</b><br><a href="#">011120</a> | <b>Vendor Name</b><br>Independence Chamber of Commerce |                                   |                                   | <b>Total Vendor Amount</b><br>20.00 |                                |
| <b>Payment Type</b><br>Check                   | <b>Payment Number</b><br><a href="#">80875</a>         |                                   | <b>Payment Date</b><br>03/20/2026 | <b>Payment Amount</b><br>20.00      |                                |
| <b>Payable Number</b><br><a href="#">3882</a>  | <b>Description</b><br>Lunch & Learn - M. Devore        | <b>Payable Date</b><br>11/17/2025 | <b>Due Date</b><br>12/17/2025     | <b>Discount Amount</b><br>0.00      | <b>Payable Amount</b><br>20.00 |

|   |   |                                   |                                   |  |                                   |
|---|---|-----------------------------------|-----------------------------------|--|-----------------------------------|
| <b>Vendor Number</b><br><a href="#">035182</a>    | <b>Vendor Name</b><br>Johnson Controls Fire Protection Lp |                                   |                                   | <b>Total Vendor Amount</b><br>1,427.09 |                                   |
| <b>Payment Type</b><br>Check                      | <b>Payment Number</b><br><a href="#">80876</a>            |                                   | <b>Payment Date</b><br>03/20/2026 | <b>Payment Amount</b><br>1,427.09      |                                   |
| <b>Payable Number</b><br><a href="#">53842911</a> | <b>Description</b><br>Mem Hall Fire Alarm                 | <b>Payable Date</b><br>02/27/2026 | <b>Due Date</b><br>03/29/2026     | <b>Discount Amount</b><br>0.00         | <b>Payable Amount</b><br>1,427.09 |

|  |  |                                   |                                   |  |                                 |
|--|--|-----------------------------------|-----------------------------------|--|---------------------------------|
| <b>Vendor Number</b><br><a href="#">038128</a> | <b>Vendor Name</b><br>Latimer, Sommers & Associates P.A. |                                   |                                   | <b>Total Vendor Amount</b><br>1,845.00 |                                 |
| <b>Payment Type</b><br>EFT                     | <b>Payment Number</b><br><a href="#">9441</a>            |                                   | <b>Payment Date</b><br>03/20/2026 | <b>Payment Amount</b><br>1,845.00      |                                 |
| <b>Payable Number</b><br><a href="#">24020</a> | <b>Description</b><br>Memorial Hall HVAC Design          | <b>Payable Date</b><br>03/16/2026 | <b>Due Date</b><br>03/16/2026     | <b>Discount Amount</b><br>0.00         | <b>Payable Amount</b><br>525.00 |
| <a href="#">24021</a>                          | Memorial Hall HVAC Design                                | 03/16/2026                        | 03/16/2026                        | 0.00                                   | 1,320.00                        |

**Payment Register**

**APPKT01887 - 3/20/2026 AP**

|   |   |                                   |                                   |                                      |                                 |
|---|---|-----------------------------------|-----------------------------------|--------------------------------------|---------------------------------|
| <b>Vendor Number</b><br><a href="#">014250</a>    | <b>Vendor Name</b><br>Lee's Cooling & Heating   |                                   |                                   | <b>Total Vendor Amount</b><br>132.50 |                                 |
| <b>Payment Type</b><br>EFT                        | <b>Payment Number</b><br><a href="#">9442</a>   |                                   | <b>Payment Date</b><br>03/20/2026 | <b>Payment Amount</b><br>132.50      |                                 |
| <b>Payable Number</b><br><a href="#">54159246</a> | <b>Description</b><br>Penn Terrace Service Call | <b>Payable Date</b><br>02/11/2026 | <b>Due Date</b><br>03/20/2026     | <b>Discount Amount</b><br>0.00       | <b>Payable Amount</b><br>132.50 |

|   |   |                                   |                                   |  |                                 |
|---|---|-----------------------------------|-----------------------------------|--|---------------------------------|
| <b>Vendor Number</b><br><a href="#">032556</a>  | <b>Vendor Name</b><br>Midwest Minerals, LLC   |                                   |                                   | <b>Total Vendor Amount</b><br>1,591.31 |                                 |
| <b>Payment Type</b><br>EFT                      | <b>Payment Number</b><br><a href="#">9443</a> |                                   | <b>Payment Date</b><br>03/20/2026 | <b>Payment Amount</b><br>1,591.31      |                                 |
| <b>Payable Number</b><br><a href="#">838584</a> | <b>Description</b><br>Rock                    | <b>Payable Date</b><br>02/25/2026 | <b>Due Date</b><br>03/27/2026     | <b>Discount Amount</b><br>0.00         | <b>Payable Amount</b><br>187.67 |
| <a href="#">839551</a>                          | Rock  | 03/03/2026                        | 04/02/2026                        | 0.00                                   | 346.45                          |
| <a href="#">839552</a>                          | Rock  | 03/03/2026                        | 04/02/2026                        | 0.00                                   | 1,057.19                        |

|   |  |                                   |                                   |  |                                 |
|---|--|-----------------------------------|-----------------------------------|--|---------------------------------|
| <b>Vendor Number</b><br><a href="#">038367</a>  | <b>Vendor Name</b><br>MoboTrex, LLC                |                                   |                                   | <b>Total Vendor Amount</b><br>1,169.00 |                                 |
| <b>Payment Type</b><br>Check                    | <b>Payment Number</b><br><a href="#">80877</a>     |                                   | <b>Payment Date</b><br>03/20/2026 | <b>Payment Amount</b><br>1,169.00      |                                 |
| <b>Payable Number</b><br><a href="#">289226</a> | <b>Description</b><br>Crossing Signal Repair Parts | <b>Payable Date</b><br>02/27/2026 | <b>Due Date</b><br>02/27/2026     | <b>Discount Amount</b><br>0.00         | <b>Payable Amount</b><br>374.00 |
| <a href="#">289290</a>                          | Pedestrian sign                                    | 03/02/2026                        | 03/02/2026                        | 0.00                                   | 795.00                          |

|  |  |                                   |                                   |                                      |                                 |
|--|--|-----------------------------------|-----------------------------------|--------------------------------------|---------------------------------|
| <b>Vendor Number</b><br><a href="#">015960</a> | <b>Vendor Name</b><br>Montgomery County Action Council |                                   |                                   | <b>Total Vendor Amount</b><br>120.00 |                                 |
| <b>Payment Type</b><br>EFT                     | <b>Payment Number</b><br><a href="#">9444</a>          |                                   | <b>Payment Date</b><br>03/20/2026 | <b>Payment Amount</b><br>120.00      |                                 |
| <b>Payable Number</b><br><a href="#">2175</a>  | <b>Description</b><br>MCAC Board Meeting Meal          | <b>Payable Date</b><br>03/16/2026 | <b>Due Date</b><br>04/15/2026     | <b>Discount Amount</b><br>0.00       | <b>Payable Amount</b><br>120.00 |

|  |   |                                   |                                   |  |                                   |
|--|---|-----------------------------------|-----------------------------------|--|-----------------------------------|
| <b>Vendor Number</b><br><a href="#">035799</a>   | <b>Vendor Name</b><br>Omni Billing            |                                   |                                   | <b>Total Vendor Amount</b><br>6,518.31 |                                   |
| <b>Payment Type</b><br>EFT                       | <b>Payment Number</b><br><a href="#">9445</a> |                                   | <b>Payment Date</b><br>03/20/2026 | <b>Payment Amount</b><br>6,518.31      |                                   |
| <b>Payable Number</b><br><a href="#">2282026</a> | <b>Description</b><br>EMS Billing             | <b>Payable Date</b><br>03/02/2026 | <b>Due Date</b><br>04/01/2026     | <b>Discount Amount</b><br>0.00         | <b>Payable Amount</b><br>6,518.31 |

|  |  |                                   |                                   |                                     |                                |
|--|--|-----------------------------------|-----------------------------------|-------------------------------------|--------------------------------|
| <b>Vendor Number</b><br><a href="#">018120</a>       | <b>Vendor Name</b><br>O'Reilly Auto Parts      |                                   |                                   | <b>Total Vendor Amount</b><br>91.12 |                                |
| <b>Payment Type</b><br>Check                         | <b>Payment Number</b><br><a href="#">80878</a> |                                   | <b>Payment Date</b><br>03/20/2026 | <b>Payment Amount</b><br>91.12      |                                |
| <b>Payable Number</b><br><a href="#">0154-294479</a> | <b>Description</b><br>Hydraulic Oil for Loader | <b>Payable Date</b><br>01/23/2026 | <b>Due Date</b><br>02/22/2026     | <b>Discount Amount</b><br>0.00      | <b>Payable Amount</b><br>74.99 |
| <a href="#">0154-301422</a>                          | RTV repair                                     | 03/05/2026                        | 04/04/2026                        | 0.00                                | 16.13                          |

|   |   |                                   |                                   |  |                                 |
|---|---|-----------------------------------|-----------------------------------|--|---------------------------------|
| <b>Vendor Number</b><br><a href="#">033876</a>      | <b>Vendor Name</b><br>Plumb-Crazy Plumbing          |                                   |                                   | <b>Total Vendor Amount</b><br>2,345.00 |                                 |
| <b>Payment Type</b><br>EFT                          | <b>Payment Number</b><br><a href="#">9446</a>       |                                   | <b>Payment Date</b><br>03/20/2026 | <b>Payment Amount</b><br>2,345.00      |                                 |
| <b>Payable Number</b><br><a href="#">INV0005182</a> | <b>Description</b><br>Water Leak in Basement Repair | <b>Payable Date</b><br>03/11/2026 | <b>Due Date</b><br>04/10/2026     | <b>Discount Amount</b><br>0.00         | <b>Payable Amount</b><br>915.00 |
| <a href="#">INV0005183</a>                          | Plumbing Repair S. 10th Street Ball Park            | 03/12/2026                        | 04/11/2026                        | 0.00                                   | 1,210.00                        |
| <a href="#">INV0005184</a>                          | ADA restroom repair                                 | 02/18/2026                        | 03/20/2026                        | 0.00                                   | 220.00                          |

|   |  |                                   |                                   |   |                                    |
|---|--|-----------------------------------|-----------------------------------|---|------------------------------------|
| <b>Vendor Number</b><br><a href="#">021300</a>          | <b>Vendor Name</b><br>Resource Recovery Div 4392 |                                   |                                   | <b>Total Vendor Amount</b><br>14,062.82 |                                    |
| <b>Payment Type</b><br>EFT                              | <b>Payment Number</b><br><a href="#">9447</a>    |                                   | <b>Payment Date</b><br>03/20/2026 | <b>Payment Amount</b><br>14,062.82      |                                    |
| <b>Payable Number</b><br><a href="#">4392-000009303</a> | <b>Description</b><br>Landfill                   | <b>Payable Date</b><br>03/15/2026 | <b>Due Date</b><br>04/14/2026     | <b>Discount Amount</b><br>0.00          | <b>Payable Amount</b><br>14,062.82 |

Payment Register

APPKT01887 - 3/20/2026 AP

| Vendor Number            | Vendor Name                  |                     |                 |                        |                       | Total Vendor Amount        |
|--------------------------|------------------------------|---------------------|-----------------|------------------------|-----------------------|----------------------------|
| <a href="#">037888</a>   | Rincks Dwood Plumbing        |                     |                 |                        |                       | 120.00                     |
| <b>Payment Type</b>      | <b>Payment Number</b>        |                     |                 | <b>Payment Date</b>    | <b>Payment Amount</b> |                            |
| EFT                      | <a href="#">9448</a>         |                     |                 | 03/20/2026             | 120.00                |                            |
| <b>Payable Number</b>    | <b>Description</b>           | <b>Payable Date</b> | <b>Due Date</b> | <b>Discount Amount</b> | <b>Payable Amount</b> |                            |
| <a href="#">5018</a>     | Cleared clog on city side    | 03/04/2026          | 04/03/2026      | 0.00                   | 120.00                |                            |
| <b>Vendor Number</b>     | <b>Vendor Name</b>           |                     |                 |                        |                       | <b>Total Vendor Amount</b> |
| <a href="#">021530</a>   | Romans Motor Company Inc.    |                     |                 |                        |                       | 676.00                     |
| <b>Payment Type</b>      | <b>Payment Number</b>        |                     |                 | <b>Payment Date</b>    | <b>Payment Amount</b> |                            |
| Check                    | <a href="#">80879</a>        |                     |                 | 03/20/2026             | 676.00                |                            |
| <b>Payable Number</b>    | <b>Description</b>           | <b>Payable Date</b> | <b>Due Date</b> | <b>Discount Amount</b> | <b>Payable Amount</b> |                            |
| <a href="#">6026429</a>  | Pickup Repair - 2018 1500    | 03/13/2026          | 04/12/2026      | 0.00                   | 676.00                |                            |
| <b>Vendor Number</b>     | <b>Vendor Name</b>           |                     |                 |                        |                       | <b>Total Vendor Amount</b> |
| <a href="#">022110</a>   | Sayers Ace Hardware Inc.     |                     |                 |                        |                       | 3.98                       |
| <b>Payment Type</b>      | <b>Payment Number</b>        |                     |                 | <b>Payment Date</b>    | <b>Payment Amount</b> |                            |
| Check                    | <a href="#">80880</a>        |                     |                 | 03/20/2026             | 3.98                  |                            |
| <b>Payable Number</b>    | <b>Description</b>           | <b>Payable Date</b> | <b>Due Date</b> | <b>Discount Amount</b> | <b>Payable Amount</b> |                            |
| <a href="#">K00931</a>   | Nuts/bolts/nails             | 03/10/2026          | 04/09/2026      | 0.00                   | 3.98                  |                            |
| <b>Vendor Number</b>     | <b>Vendor Name</b>           |                     |                 |                        |                       | <b>Total Vendor Amount</b> |
| <a href="#">038320</a>   | Sunflower Horseshoeing       |                     |                 |                        |                       | 40.00                      |
| <b>Payment Type</b>      | <b>Payment Number</b>        |                     |                 | <b>Payment Date</b>    | <b>Payment Amount</b> |                            |
| EFT                      | <a href="#">9449</a>         |                     |                 | 03/20/2026             | 40.00                 |                            |
| <b>Payable Number</b>    | <b>Description</b>           | <b>Payable Date</b> | <b>Due Date</b> | <b>Discount Amount</b> | <b>Payable Amount</b> |                            |
| <a href="#">537416</a>   | donkey trim                  | 03/07/2026          | 03/07/2026      | 0.00                   | 40.00                 |                            |
| <b>Vendor Number</b>     | <b>Vendor Name</b>           |                     |                 |                        |                       | <b>Total Vendor Amount</b> |
| <a href="#">038371</a>   | Tamara Kolbinskie            |                     |                 |                        |                       | 23.99                      |
| <b>Payment Type</b>      | <b>Payment Number</b>        |                     |                 | <b>Payment Date</b>    | <b>Payment Amount</b> |                            |
| EFT                      | <a href="#">9450</a>         |                     |                 | 03/20/2026             | 23.99                 |                            |
| <b>Payable Number</b>    | <b>Description</b>           | <b>Payable Date</b> | <b>Due Date</b> | <b>Discount Amount</b> | <b>Payable Amount</b> |                            |
| <a href="#">03102026</a> | Ergonomic mouse pad          | 03/08/2026          | 03/08/2026      | 0.00                   | 23.99                 |                            |
| <b>Vendor Number</b>     | <b>Vendor Name</b>           |                     |                 |                        |                       | <b>Total Vendor Amount</b> |
| <a href="#">034515</a>   | Tidy Whitie's Laundromat     |                     |                 |                        |                       | 22.50                      |
| <b>Payment Type</b>      | <b>Payment Number</b>        |                     |                 | <b>Payment Date</b>    | <b>Payment Amount</b> |                            |
| EFT                      | <a href="#">9451</a>         |                     |                 | 03/20/2026             | 22.50                 |                            |
| <b>Payable Number</b>    | <b>Description</b>           | <b>Payable Date</b> | <b>Due Date</b> | <b>Discount Amount</b> | <b>Payable Amount</b> |                            |
| <a href="#">7063</a>     | Wash and fold                | 03/02/2026          | 04/01/2026      | 0.00                   | 22.50                 |                            |
| <b>Vendor Number</b>     | <b>Vendor Name</b>           |                     |                 |                        |                       | <b>Total Vendor Amount</b> |
| <a href="#">032956</a>   | TLC Nursery & Outdoor Living |                     |                 |                        |                       | 717.00                     |
| <b>Payment Type</b>      | <b>Payment Number</b>        |                     |                 | <b>Payment Date</b>    | <b>Payment Amount</b> |                            |
| EFT                      | <a href="#">9452</a>         |                     |                 | 03/20/2026             | 717.00                |                            |
| <b>Payable Number</b>    | <b>Description</b>           | <b>Payable Date</b> | <b>Due Date</b> | <b>Discount Amount</b> | <b>Payable Amount</b> |                            |
| <a href="#">12200</a>    | Winter Weather Snow          | 03/02/2026          | 04/01/2026      | 0.00                   | 717.00                |                            |
| <b>Vendor Number</b>     | <b>Vendor Name</b>           |                     |                 |                        |                       | <b>Total Vendor Amount</b> |
| <a href="#">038360</a>   | TLC Outdoor Power LLC        |                     |                 |                        |                       | 980.35                     |
| <b>Payment Type</b>      | <b>Payment Number</b>        |                     |                 | <b>Payment Date</b>    | <b>Payment Amount</b> |                            |
| Check                    | <a href="#">80881</a>        |                     |                 | 03/20/2026             | 980.35                |                            |
| <b>Payable Number</b>    | <b>Description</b>           | <b>Payable Date</b> | <b>Due Date</b> | <b>Discount Amount</b> | <b>Payable Amount</b> |                            |
| <a href="#">1805</a>     | Hustler Mower Servicing      | 03/05/2026          | 03/05/2026      | 0.00                   | 378.03                |                            |
| <a href="#">1806</a>     | Hustler Mower Servicing      | 03/05/2026          | 03/05/2026      | 0.00                   | 602.32                |                            |

**Payment Register**

**APPKT01887 - 3/20/2026 AP**

|   |  |                                   |                               |                                |                                |                                     |
|---|--|-----------------------------------|-------------------------------|--------------------------------|--------------------------------|-------------------------------------|
| <b>Vendor Number</b><br><a href="#">035378</a>      | <b>Vendor Name</b><br>Verizon Wireless         |                                   |                               |                                |                                | <b>Total Vendor Amount</b><br>80.06 |
| <b>Payment Type</b><br>Check                        | <b>Payment Number</b><br><a href="#">80882</a> | <b>Payment Date</b><br>03/20/2026 |                               |                                | <b>Payment Amount</b><br>80.06 |                                     |
| <b>Payable Number</b><br><a href="#">6138044073</a> | <b>Description</b><br>SE Liftstation           | <b>Payable Date</b><br>03/08/2026 | <b>Due Date</b><br>04/07/2026 | <b>Discount Amount</b><br>0.00 | <b>Payable Amount</b><br>80.06 |                                     |

|  |  |                                   |                               |                                |                                   |  |
|--|--|-----------------------------------|-------------------------------|--------------------------------|-----------------------------------|--|
| <b>Vendor Number</b><br><a href="#">026090</a>       | <b>Vendor Name</b><br>VLP An Equipmentsshare Company |                                   |                               |                                |                                   | <b>Total Vendor Amount</b><br>8,271.27 |
| <b>Payment Type</b><br>Check                         | <b>Payment Number</b><br><a href="#">80883</a>       | <b>Payment Date</b><br>03/20/2026 |                               |                                | <b>Payment Amount</b><br>8,271.27 |  |
| <b>Payable Number</b><br><a href="#">6514348-000</a> | <b>Description</b><br>Backhoe Air Ride Seat Repair   | <b>Payable Date</b><br>02/25/2026 | <b>Due Date</b><br>03/27/2026 | <b>Discount Amount</b><br>0.00 | <b>Payable Amount</b><br>925.65   |  |
| <a href="#">6515235-000</a>                          | Backhoe Service                                      | 02/26/2026                        | 03/28/2026                    | 0.00                           | 4,346.55                          |  |
| <a href="#">6515561-000</a>                          | Backhoe Repair                                       | 02/26/2026                        | 03/28/2026                    | 0.00                           | 2,999.07                          |  |

|   |  |                                   |                               |                                |                                   |  |
|---|--|-----------------------------------|-------------------------------|--------------------------------|-----------------------------------|--|
| <b>Vendor Number</b><br><a href="#">035913</a>  | <b>Vendor Name</b><br>Waters Hardware                                |                                   |                               |                                |                                   | <b>Total Vendor Amount</b><br>2,646.40 |
| <b>Payment Type</b><br>EFT                      | <b>Payment Number</b><br><a href="#">9453</a>                        | <b>Payment Date</b><br>03/20/2026 |                               |                                | <b>Payment Amount</b><br>2,646.40 |  |
| <b>Payable Number</b><br><a href="#">6858/P</a> | <b>Description</b><br>Cust no 72177 - Sash Chain and Office Supplies | <b>Payable Date</b><br>10/07/2025 | <b>Due Date</b><br>11/06/2025 | <b>Discount Amount</b><br>0.00 | <b>Payable Amount</b><br>50.73    |  |
| <a href="#">6920/P</a>                          | Cust no 72177 - Bolts and screws                                     | 10/14/2025                        | 11/13/2025                    | 0.00                           | 11.96                             |  |
| <a href="#">6984/P</a>                          | Cust no 72177 - Bottled Water  | 10/21/2025                        | 11/20/2025                    | 0.00                           | 413.31                            |  |
| <a href="#">7199/P</a>                          | Cust no 72177 - Extension Cords                                      | 11/07/2025                        | 12/07/2025                    | 0.00                           | 86.95                             |  |
| <a href="#">7317/P</a>                          | Cust no 72177 - Pipe and sealant                                     | 11/18/2025                        | 12/18/2025                    | 0.00                           | 18.47                             |  |
| <a href="#">7440/P</a>                          | Cust no 72182 - Stepladder   | 11/26/2025                        | 12/26/2025                    | 0.00                           | 328.48                            |  |
| <a href="#">7526/P</a>                          | Cust no 72177 - Chain  | 12/05/2025                        | 01/04/2026                    | 0.00                           | 15.38                             |  |
| <a href="#">7824/P</a>                          | Cust no 72182 - Keys Cut   | 01/06/2026                        | 02/05/2026                    | 0.00                           | 10.90                             |  |
| <a href="#">7837/P</a>                          | Cut no 72177 - Coupling and Clamp                                    | 01/07/2026                        | 02/06/2026                    | 0.00                           | 21.12                             |  |
| <a href="#">7859/P</a>                          | Cut no 72177 - Refrigerator  | 01/08/2026                        | 02/07/2026                    | 0.00                           | 899.99                            |  |
| <a href="#">7860/P</a>                          | Cust no 72177 - Measuring Wheel                                      | 01/08/2026                        | 02/07/2026                    | 0.00                           | 46.97                             |  |
| <a href="#">7931/P</a>                          | Cust no 72177 - Coupling   | 01/13/2026                        | 02/12/2026                    | 0.00                           | 5.99                              |  |
| <a href="#">7951/P</a>                          | Cust no 72177 - Heater, Rope, Fittings                               | 01/15/2026                        | 02/14/2026                    | 0.00                           | 102.96                            |  |
| <a href="#">8036/P</a>                          | Cuat no 72182 - Bottled Water  | 01/22/2026                        | 02/21/2026                    | 0.00                           | 30.85                             |  |
| <a href="#">8082/P</a>                          | Cust no 72177 - Ice Cutter   | 01/26/2026                        | 02/25/2026                    | 0.00                           | 37.98                             |  |
| <a href="#">8294/P</a>                          | Cust no72177 - Respr and Stainless Steel Brushes                     | 02/10/2026                        | 03/12/2026                    | 0.00                           | 93.94                             |  |
| <a href="#">8299/P</a>                          | Cust no 72177 - Lantern Battery                                      | 02/10/2026                        | 03/12/2026                    | 0.00                           | 13.98                             |  |
| <a href="#">8361/P</a>                          | Cust no 72177 - Pipe fittings and sealant                            | 02/13/2026                        | 03/15/2026                    | 0.00                           | 246.49                            |  |
| <a href="#">8682/P</a>                          | Cust no 72177 - concessions table repair                             | 03/11/2026                        | 04/10/2026                    | 0.00                           | 11.98                             |  |
| <a href="#">8714/P</a>                          | Cust no 72177 - Pressure washer supplies                             | 03/13/2026                        | 04/12/2026                    | 0.00                           | 197.97                            |  |

|   |   |                                   |                               |                                |                                   |  |
|---|---|-----------------------------------|-------------------------------|--------------------------------|-----------------------------------|--|
| <b>Vendor Number</b><br><a href="#">034744</a>  | <b>Vendor Name</b><br>Woods Lumber Company    |                                   |                               |                                |                                   | <b>Total Vendor Amount</b><br>1,402.99 |
| <b>Payment Type</b><br>EFT                      | <b>Payment Number</b><br><a href="#">9455</a> | <b>Payment Date</b><br>03/20/2026 |                               |                                | <b>Payment Amount</b><br>1,402.99 |  |
| <b>Payable Number</b><br><a href="#">618420</a> | <b>Description</b><br>Lumber and screws       | <b>Payable Date</b><br>10/06/2025 | <b>Due Date</b><br>11/05/2025 | <b>Discount Amount</b><br>0.00 | <b>Payable Amount</b><br>61.54    |  |
| <a href="#">622241</a>                          | Drill and bit rental                          | 11/06/2025                        | 12/06/2025                    | 0.00                           | 185.00                            |  |
| <a href="#">627289</a>                          | Sawzall and recipical blades                  | 12/23/2025                        | 01/22/2026                    | 0.00                           | 41.48                             |  |
| <a href="#">629123</a>                          | Lumber  | 01/13/2026                        | 02/12/2026                    | 0.00                           | 2.28                              |  |
| <a href="#">629860</a>                          | Steel Wool Pads                               | 01/21/2026                        | 02/20/2026                    | 0.00                           | 10.28                             |  |
| <a href="#">631654</a>                          | Lumber  | 02/09/2026                        | 03/11/2026                    | 0.00                           | 23.69                             |  |
| <a href="#">632686</a>                          | Mini Pendant Lights                           | 02/19/2026                        | 03/21/2026                    | 0.00                           | 199.95                            |  |
| <a href="#">633071</a>                          | Angle Stop/Supply Line                        | 02/24/2026                        | 03/26/2026                    | 0.00                           | 96.95                             |  |
| <a href="#">634481</a>                          | Concession building supplies                  | 03/09/2026                        | 04/08/2026                    | 0.00                           | 146.60                            |  |
| <a href="#">634482</a>                          | barn supplies                                 | 03/09/2026                        | 04/08/2026                    | 0.00                           | 70.67                             |  |
| <a href="#">634633</a>                          | mini golf fence and building supplies         | 03/10/2026                        | 04/09/2026                    | 0.00                           | 314.04                            |  |
| <a href="#">634637</a>                          | plumbing supplies                             | 03/10/2026                        | 04/09/2026                    | 0.00                           | 88.09                             |  |
| <a href="#">634650</a>                          | plumbing supplies                             | 03/10/2026                        | 04/09/2026                    | 0.00                           | 3.58                              |  |
| <a href="#">634666</a>                          | plumbing supplies                             | 03/10/2026                        | 04/09/2026                    | 0.00                           | 33.99                             |  |
| <a href="#">634688</a>                          | plumbing supplies                             | 03/10/2026                        | 04/09/2026                    | 0.00                           | 96.71                             |  |

**Payment Register**

**APPKT01887 - 3/20/2026 AP**

[634751](#) plumbing supplies 03/11/2026 04/10/2026 0.00 28.14

| Vendor Number          | Vendor Name         | Total Vendor Amount |
|------------------------|---------------------|---------------------|
| <a href="#">037036</a> | Zinser Electric LLC | 221.65              |

| Payment Type | Payment Number       | Payment Date | Payment Amount |
|--------------|----------------------|--------------|----------------|
| EFT          | <a href="#">9457</a> | 03/20/2026   | 221.65         |

| Payable Number       | Description     | Payable Date | Due Date   | Discount Amount | Payable Amount |
|----------------------|-----------------|--------------|------------|-----------------|----------------|
| <a href="#">3204</a> | Security / Fire | 04/01/2026   | 05/01/2026 | 0.00            | 221.65         |

**Payment Summary**

| Bank Code             | Type              | Payable<br>Count | Payment<br>Count | Discount    | Payment           |
|-----------------------|-------------------|------------------|------------------|-------------|-------------------|
| General               | Check             | 37               | 18               | 0.00        | 36,715.51         |
| General               | EFT               | 3                | 1                | 0.00        | 1,591.31          |
| General               | Voided **Void EFT | 0                | 1                | 0.00        | 0.00              |
| General               | EFT               | 5                | 3                | 0.00        | 118,883.20        |
| General               | Voided **Void EFT | 0                | 1                | 0.00        | 0.00              |
| General               | EFT               | 96               | 27               | 0.00        | 266,020.97        |
| General               | Voided **Void EFT | 0                | 1                | 0.00        | 0.00              |
| General               | EFT               | 7                | 3                | 0.00        | 5,011.42          |
| General               | Voided **Void EFT | 0                | 1                | 0.00        | 0.00              |
| <b>Packet Totals:</b> |                   | <b>148</b>       | <b>56</b>        | <b>0.00</b> | <b>428,222.41</b> |

### Cash Fund Summary

| Fund                  | Name        | Amount             |
|-----------------------|-------------|--------------------|
| 099                   | Pooled Cash | -428,222.41        |
| <b>Packet Totals:</b> |             | <b>-428,222.41</b> |



Bank: General - Community National Bank

|                       |                       |                     |                       |                                       |
|-----------------------|-----------------------|---------------------|-----------------------|---------------------------------------|
| <b>Vendor Number</b>  | <b>Vendor Name</b>    |                     |                       | <b>Total Vendor Amount</b>            |
|                       | **Void**              |                     |                       | 0.00                                  |
| <b>Payment Type</b>   | <b>Payment Number</b> | <b>Payment Date</b> | <b>Payment Amount</b> |                                       |
| **Void EFT            | <a href="#">9470</a>  | 03/27/2026          | 0.00                  |                                       |
| <b>Payable Number</b> | <b>Description</b>    | <b>Payable Date</b> | <b>Due Date</b>       | <b>Discount Amount Payable Amount</b> |
|                       |                       |                     |                       | 0.00 0.00                             |

|                        |                                    |                     |                       |                                       |
|------------------------|------------------------------------|---------------------|-----------------------|---------------------------------------|
| <b>Vendor Number</b>   | <b>Vendor Name</b>                 |                     |                       | <b>Total Vendor Amount</b>            |
| <a href="#">035900</a> | Ane Mae's Coffee And Sandwich Shop |                     |                       | 190.90                                |
| <b>Payment Type</b>    | <b>Payment Number</b>              | <b>Payment Date</b> | <b>Payment Amount</b> |                                       |
| EFT                    | <a href="#">9458</a>               | 03/27/2026          | 190.90                |                                       |
| <b>Payable Number</b>  | <b>Description</b>                 | <b>Payable Date</b> | <b>Due Date</b>       | <b>Discount Amount Payable Amount</b> |
| <a href="#">13306</a>  | Meeting                            | 03/18/2026          | 04/17/2026            | 0.00 43.20                            |
| <a href="#">13321</a>  | Lunch                              | 03/24/2026          | 04/23/2026            | 0.00 147.70                           |

|                        |                       |                     |                       |                                       |
|------------------------|-----------------------|---------------------|-----------------------|---------------------------------------|
| <b>Vendor Number</b>   | <b>Vendor Name</b>    |                     |                       | <b>Total Vendor Amount</b>            |
| <a href="#">038287</a> | Ashcraft Tire & Auto  |                     |                       | 9,409.84                              |
| <b>Payment Type</b>    | <b>Payment Number</b> | <b>Payment Date</b> | <b>Payment Amount</b> |                                       |
| EFT                    | <a href="#">9459</a>  | 03/27/2026          | 9,409.84              |                                       |
| <b>Payable Number</b>  | <b>Description</b>    | <b>Payable Date</b> | <b>Due Date</b>       | <b>Discount Amount Payable Amount</b> |
| <a href="#">051648</a> | Tire Stocking         | 01/23/2026          | 02/22/2026            | 0.00 1,847.24                         |
| <a href="#">051803</a> | Tire Stocking         | 02/11/2026          | 03/13/2026            | 0.00 2,111.72                         |
| <a href="#">051810</a> | Tire Stocking         | 02/12/2026          | 03/14/2026            | 0.00 3,160.08                         |
| <a href="#">051988</a> | 603 Tire Installation | 03/05/2026          | 04/04/2026            | 0.00 296.64                           |
| <a href="#">052022</a> | Tire Stocking         | 03/09/2026          | 04/08/2026            | 0.00 1,994.16                         |

|                            |                                    |                     |                       |                                       |
|----------------------------|------------------------------------|---------------------|-----------------------|---------------------------------------|
| <b>Vendor Number</b>       | <b>Vendor Name</b>                 |                     |                       | <b>Total Vendor Amount</b>            |
| <a href="#">037944</a>     | Atmos                              |                     |                       | 358.82                                |
| <b>Payment Type</b>        | <b>Payment Number</b>              | <b>Payment Date</b> | <b>Payment Amount</b> |                                       |
| Check                      | <a href="#">80884</a>              | 03/27/2026          | 358.82                |                                       |
| <b>Payable Number</b>      | <b>Description</b>                 | <b>Payable Date</b> | <b>Due Date</b>       | <b>Discount Amount Payable Amount</b> |
| <a href="#">INV0005298</a> | Acct #3076622140 - 500 Catalpa Gas | 03/13/2026          | 04/12/2026            | 0.00 69.58                            |
| <a href="#">INV0005299</a> | Acct #3076622104 - 506 Catalpa Gas | 03/13/2026          | 04/12/2026            | 0.00 78.52                            |
| <a href="#">INV0005300</a> | Acct #3076622177 - 512 Catalpa Gas | 03/16/2026          | 04/15/2026            | 0.00 87.37                            |
| <a href="#">INV0005301</a> | Acct #3076622186 600 Catalpa Gas   | 03/16/2026          | 04/15/2026            | 0.00 88.23                            |
| <a href="#">INV0005302</a> | Acct #3076953702 - 606 Catalpa Gas | 03/13/2026          | 04/12/2026            | 0.00 35.12                            |

|                        |                                  |                     |                       |                                       |
|------------------------|----------------------------------|---------------------|-----------------------|---------------------------------------|
| <b>Vendor Number</b>   | <b>Vendor Name</b>               |                     |                       | <b>Total Vendor Amount</b>            |
| <a href="#">037925</a> | Bartlett Cooperative Association |                     |                       | 692.45                                |
| <b>Payment Type</b>    | <b>Payment Number</b>            | <b>Payment Date</b> | <b>Payment Amount</b> |                                       |
| Check                  | <a href="#">80885</a>            | 03/27/2026          | 692.45                |                                       |
| <b>Payable Number</b>  | <b>Description</b>               | <b>Payable Date</b> | <b>Due Date</b>       | <b>Discount Amount Payable Amount</b> |
| <a href="#">633141</a> | Diesel                           | 02/23/2026          | 03/25/2026            | 0.00 692.45                           |

|                        |                                   |                     |                       |                                       |
|------------------------|-----------------------------------|---------------------|-----------------------|---------------------------------------|
| <b>Vendor Number</b>   | <b>Vendor Name</b>                |                     |                       | <b>Total Vendor Amount</b>            |
| <a href="#">037975</a> | Benefit Technology Resources, LLC |                     |                       | 200.00                                |
| <b>Payment Type</b>    | <b>Payment Number</b>             | <b>Payment Date</b> | <b>Payment Amount</b> |                                       |
| EFT                    | <a href="#">9460</a>              | 03/27/2026          | 200.00                |                                       |
| <b>Payable Number</b>  | <b>Description</b>                | <b>Payable Date</b> | <b>Due Date</b>       | <b>Discount Amount Payable Amount</b> |
| <a href="#">41990</a>  | Employee Navigator Monthly Fees   | 03/17/2026          | 04/16/2026            | 0.00 200.00                           |

**Payment Register**

**APPKT01902 - 3/27/2026 AP**

|  |   |                                   |                               |                                   |  |                                      |
|--|---|-----------------------------------|-------------------------------|-----------------------------------|--|--------------------------------------|
| <b>Vendor Number</b><br><a href="#">038284</a> | <b>Vendor Name</b><br>Blake Kirk                |                                   |                               |                                   |  | <b>Total Vendor Amount</b><br>143.69 |
| <b>Payment Type</b><br>EFT                     | <b>Payment Number</b><br><a href="#">9461</a>   |                                   |                               | <b>Payment Date</b><br>03/27/2026 |  | <b>Payment Amount</b><br>143.69      |
| <b>Payable Number</b><br><a href="#">78742</a> | <b>Description</b><br>Refund of Bonus Repayment | <b>Payable Date</b><br>03/13/2026 | <b>Due Date</b><br>04/12/2026 | <b>Discount Amount</b><br>0.00    |  | <b>Payable Amount</b><br>143.69      |

|  |  |                                   |                               |                                   |  |  |
|--|--|-----------------------------------|-------------------------------|-----------------------------------|--|--|
| <b>Vendor Number</b><br><a href="#">038174</a> | <b>Vendor Name</b><br>Casey's Automotive LLC         |                                   |                               |                                   |  | <b>Total Vendor Amount</b><br>1,563.20 |
| <b>Payment Type</b><br>Check                   | <b>Payment Number</b><br><a href="#">80886</a>       |                                   |                               | <b>Payment Date</b><br>03/27/2026 |  | <b>Payment Amount</b><br>1,563.20      |
| <b>Payable Number</b><br><a href="#">21045</a> | <b>Description</b><br>Spark Plugs and oil Change 601 | <b>Payable Date</b><br>03/04/2026 | <b>Due Date</b><br>03/04/2026 | <b>Discount Amount</b><br>0.00    |  | <b>Payable Amount</b><br>1,563.20      |

|   |   |                                   |                               |                                   |  |                                      |
|---|---|-----------------------------------|-------------------------------|-----------------------------------|--|--------------------------------------|
| <b>Vendor Number</b><br><a href="#">033027</a>      | <b>Vendor Name</b><br>Cintas Corporation      |                                   |                               |                                   |  | <b>Total Vendor Amount</b><br>448.79 |
| <b>Payment Type</b><br>EFT                          | <b>Payment Number</b><br><a href="#">9462</a> |                                   |                               | <b>Payment Date</b><br>03/27/2026 |  | <b>Payment Amount</b><br>448.79      |
| <b>Payable Number</b><br><a href="#">5319897007</a> | <b>Description</b><br>Sanitation First Aid    | <b>Payable Date</b><br>02/23/2026 | <b>Due Date</b><br>03/25/2026 | <b>Discount Amount</b><br>0.00    |  | <b>Payable Amount</b><br>416.24      |
| <a href="#">5319897009</a>                          | Sanitation First Aid                          | 02/23/2026                        | 03/25/2026                    | 0.00                              |  | 22.02                                |
| <a href="#">5322995106</a>                          | Cleaning supplies                             | 03/11/2026                        | 04/10/2026                    | 0.00                              |  | 10.53                                |

|   |  |                                   |                               |                                   |  |   |
|---|--|-----------------------------------|-------------------------------|-----------------------------------|--|---|
| <b>Vendor Number</b><br><a href="#">034663</a>      | <b>Vendor Name</b><br>Community National Bank  |                                   |                               |                                   |  | <b>Total Vendor Amount</b><br>99,348.60 |
| <b>Payment Type</b><br>Check                        | <b>Payment Number</b><br><a href="#">80887</a> |                                   |                               | <b>Payment Date</b><br>03/27/2026 |  | <b>Payment Amount</b><br>99,348.60      |
| <b>Payable Number</b><br><a href="#">April 2026</a> | <b>Description</b><br>Fire Truck Payment       | <b>Payable Date</b><br>03/20/2026 | <b>Due Date</b><br>04/19/2026 | <b>Discount Amount</b><br>0.00    |  | <b>Payable Amount</b><br>99,348.60      |

|   |   |                                   |                               |                                   |  |   |
|---|---|-----------------------------------|-------------------------------|-----------------------------------|--|---|
| <b>Vendor Number</b><br><a href="#">034221</a>      | <b>Vendor Name</b><br>Core & Main                     |                                   |                               |                                   |  | <b>Total Vendor Amount</b><br>11,667.80 |
| <b>Payment Type</b><br>EFT                          | <b>Payment Number</b><br><a href="#">9463</a>         |                                   |                               | <b>Payment Date</b><br>03/27/2026 |  | <b>Payment Amount</b><br>11,667.80      |
| <b>Payable Number</b><br><a href="#">INV0027729</a> | <b>Description</b><br>Chlorine Reagent Powder Pillows | <b>Payable Date</b><br>03/13/2026 | <b>Due Date</b><br>04/12/2026 | <b>Discount Amount</b><br>0.00    |  | <b>Payable Amount</b><br>86.60          |
| <a href="#">Y614407</a>                             | Hydrants  | 03/12/2026                        | 04/11/2026                    | 0.00                              |  | 11,366.88                               |
| <a href="#">Y637590</a>                             | Adaptor   | 03/12/2026                        | 04/11/2026                    | 0.00                              |  | 214.32                                  |

|  |   |                                   |                               |                                   |  |                                      |
|--|---|-----------------------------------|-------------------------------|-----------------------------------|--|--------------------------------------|
| <b>Vendor Number</b><br><a href="#">038082</a>     | <b>Vendor Name</b><br>CPI Financing LLC       |                                   |                               |                                   |  | <b>Total Vendor Amount</b><br>852.78 |
| <b>Payment Type</b><br>EFT                         | <b>Payment Number</b><br><a href="#">9464</a> |                                   |                               | <b>Payment Date</b><br>03/27/2026 |  | <b>Payment Amount</b><br>852.78      |
| <b>Payable Number</b><br><a href="#">CPIF30414</a> | <b>Description</b><br>Printing                | <b>Payable Date</b><br>03/25/2026 | <b>Due Date</b><br>04/24/2026 | <b>Discount Amount</b><br>0.00    |  | <b>Payable Amount</b><br>852.78      |

|  |   |                                   |                               |                                   |  |                                      |
|--|---|-----------------------------------|-------------------------------|-----------------------------------|--|--------------------------------------|
| <b>Vendor Number</b><br><a href="#">032078</a> | <b>Vendor Name</b><br>CPR Pest Management, Inc. |                                   |                               |                                   |  | <b>Total Vendor Amount</b><br>147.50 |
| <b>Payment Type</b><br>EFT                     | <b>Payment Number</b><br><a href="#">9465</a>   |                                   |                               | <b>Payment Date</b><br>03/27/2026 |  | <b>Payment Amount</b><br>147.50      |
| <b>Payable Number</b><br><a href="#">50366</a> | <b>Description</b><br>AWOL Pest Control         | <b>Payable Date</b><br>03/19/2026 | <b>Due Date</b><br>04/18/2026 | <b>Discount Amount</b><br>0.00    |  | <b>Payable Amount</b><br>27.50       |
| <a href="#">50399</a>                          | City Hall Pest Control                          | 03/19/2026                        | 04/18/2026                    | 0.00                              |  | 120.00                               |

|  |   |                                   |                               |                                   |  |   |
|--|---|-----------------------------------|-------------------------------|-----------------------------------|--|---|
| <b>Vendor Number</b><br><a href="#">037822</a> | <b>Vendor Name</b><br>Evans, Bierly, Hutchison & Associates, P.A. |                                   |                               |                                   |  | <b>Total Vendor Amount</b><br>24,609.30 |
| <b>Payment Type</b><br>EFT                     | <b>Payment Number</b><br><a href="#">9466</a>                     |                                   |                               | <b>Payment Date</b><br>03/27/2026 |  | <b>Payment Amount</b><br>24,609.30      |
| <b>Payable Number</b><br><a href="#">16539</a> | <b>Description</b><br>WATER TRANSMISSION LINE                     | <b>Payable Date</b><br>02/24/2026 | <b>Due Date</b><br>03/26/2026 | <b>Discount Amount</b><br>0.00    |  | <b>Payable Amount</b><br>23,234.30      |
| <a href="#">16545</a>                          | Water Study   | 02/24/2026                        | 03/26/2026                    | 0.00                              |  | 1,375.00                                |

**Payment Register**

**APPKT01902 - 3/27/2026 AP**

| Vendor Number                           | Vendor Name  |                     |                 |                        |                       | Total Vendor Amount |
|---|--|---------------------|-----------------|------------------------|-----------------------|---------------------|
| <a href="#">037979</a>                  | Evergy   |                     |                 |                        |                       | 155.64              |
| <b>Payment Type</b>                     | <b>Payment Number</b>                              |                     |                 | <b>Payment Date</b>    | <b>Payment Amount</b> |                     |
| Check                                   | <a href="#">80888</a>                              |                     |                 | 03/27/2026             | 155.64                |                     |
| <b>Payable Number</b>                   | <b>Description</b>                                 | <b>Payable Date</b> | <b>Due Date</b> | <b>Discount Amount</b> | <b>Payable Amount</b> |                     |
| <a href="#">INV0005296</a>              | Acct 9103034205 - 704 N 13th/1009 C Cedar/408 Earl | 03/17/2026          | 03/17/2026      | 0.00                   | 128.74                |                     |
| <a href="#">INV0005297</a>              | Acct 9982921045 - 506 Catalpa Electric             | 03/11/2026          | 03/11/2026      | 0.00                   | 26.90                 |                     |
| <a href="#">035115</a>                  | Express Services, Inc.                             |                     |                 |                        |                       | 12,977.28           |
| <b>Payment Type</b>                     | <b>Payment Number</b>                              |                     |                 | <b>Payment Date</b>    | <b>Payment Amount</b> |                     |
| EFT                                     | <a href="#">9467</a>                               |                     |                 | 03/27/2026             | 12,977.28             |                     |
| <b>Payable Number</b>                   | <b>Description</b>                                 | <b>Payable Date</b> | <b>Due Date</b> | <b>Discount Amount</b> | <b>Payable Amount</b> |                     |
| <a href="#">33643970</a>                | Express Employment                                 | 03/18/2026          | 04/17/2026      | 0.00                   | 12,977.28             |                     |
| <a href="#">032155</a>                  | Family Support Payment Center                      |                     |                 |                        |                       | 173.08              |
| <b>Payment Type</b>                     | <b>Payment Number</b>                              |                     |                 | <b>Payment Date</b>    | <b>Payment Amount</b> |                     |
| Check                                   | <a href="#">80889</a>                              |                     |                 | 03/27/2026             | 173.08                |                     |
| <b>Payable Number</b>                   | <b>Description</b>                                 | <b>Payable Date</b> | <b>Due Date</b> | <b>Discount Amount</b> | <b>Payable Amount</b> |                     |
| <a href="#">INV0005287</a>              | [REDACTED]   | 03/27/2026          | 03/27/2026      | 0.00                   | 173.08                |                     |
| <a href="#">038288</a>                  | First Step Builders LLC                            |                     |                 |                        |                       | 20,000.00           |
| <b>Payment Type</b>                     | <b>Payment Number</b>                              |                     |                 | <b>Payment Date</b>    | <b>Payment Amount</b> |                     |
| EFT                                     | <a href="#">9468</a>                               |                     |                 | 03/27/2026             | 20,000.00             |                     |
| <b>Payable Number</b>                   | <b>Description</b>                                 | <b>Payable Date</b> | <b>Due Date</b> | <b>Discount Amount</b> | <b>Payable Amount</b> |                     |
| <a href="#">INV0005295</a>              | Jefferson Subdivision 507 & 517 Pearl Lot Reimburs | 03/25/2026          | 04/24/2026      | 0.00                   | 20,000.00             |                     |
| <a href="#">037139</a>                  | Fleet Fuels, LLC                                   |                     |                 |                        |                       | 4,731.66            |
| <b>Payment Type</b>                     | <b>Payment Number</b>                              |                     |                 | <b>Payment Date</b>    | <b>Payment Amount</b> |                     |
| EFT                                     | <a href="#">9469</a>                               |                     |                 | 03/27/2026             | 4,731.66              |                     |
| <b>Payable Number</b>                   | <b>Description</b>                                 | <b>Payable Date</b> | <b>Due Date</b> | <b>Discount Amount</b> | <b>Payable Amount</b> |                     |
| <a href="#">CFSI-50646</a>              | Fire/EMS Fuel                                      | 03/22/2026          | 04/21/2026      | 0.00                   | 1,637.75              |                     |
| <a href="#">CFSI-50647</a>              | Fuel   | 03/22/2026          | 04/21/2026      | 0.00                   | 54.84                 |                     |
| <a href="#">CFSI-50648</a>              | Park Dept. Fuel                                    | 03/22/2026          | 04/21/2026      | 0.00                   | 124.44                |                     |
| <a href="#">CFSI-50649</a>              | Police Fuel  | 03/22/2026          | 04/21/2026      | 0.00                   | 537.13                |                     |
| <a href="#">CFSI-50650</a>              | Public Safety Director Fuel                        | 03/22/2026          | 04/21/2026      | 0.00                   | 45.10                 |                     |
| <a href="#">CFSI-50651</a>              | Sewer Collection Fuel                              | 03/22/2026          | 04/21/2026      | 0.00                   | 293.87                |                     |
| <a href="#">CFSI-50652</a>              | Street Fuel  | 03/22/2026          | 04/21/2026      | 0.00                   | 760.41                |                     |
| <a href="#">CFSI-50653</a>              | Water Distribution Fuel                            | 03/22/2026          | 04/21/2026      | 0.00                   | 189.47                |                     |
| <a href="#">CFSI-50654</a>              | Water/Sewer Administration Fuel                    | 03/22/2026          | 04/21/2026      | 0.00                   | 105.44                |                     |
| <a href="#">CFSI-50655</a>              | Water Treatment Fuel                               | 03/22/2026          | 04/21/2026      | 0.00                   | 46.48                 |                     |
| <a href="#">CFSI-50656</a>              | Sanitation Fuel                                    | 03/22/2026          | 04/21/2026      | 0.00                   | 936.73                |                     |
| <a href="#">034052</a>                  | Garsite Progress LLC                               |                     |                 |                        |                       | 2,782.71            |
| <b>Payment Type</b>                     | <b>Payment Number</b>                              |                     |                 | <b>Payment Date</b>    | <b>Payment Amount</b> |                     |
| EFT                                     | <a href="#">9471</a>                               |                     |                 | 03/27/2026             | 2,782.71              |                     |
| <b>Payable Number</b>                   | <b>Description</b>                                 | <b>Payable Date</b> | <b>Due Date</b> | <b>Discount Amount</b> | <b>Payable Amount</b> |                     |
| <a href="#">INV15136-2</a>              | Jet Bowser Parts                                   | 11/10/2025          | 12/10/2025      | 0.00                   | 2,782.71              |                     |
| <a href="#">038343</a>                  | Glen Chase Hunter                                  |                     |                 |                        |                       | 3,000.00            |
| <b>Payment Type</b>                     | <b>Payment Number</b>                              |                     |                 | <b>Payment Date</b>    | <b>Payment Amount</b> |                     |
| EFT                                     | <a href="#">9472</a>                               |                     |                 | 03/27/2026             | 3,000.00              |                     |
| <b>Payable Number</b>                   | <b>Description</b>                                 | <b>Payable Date</b> | <b>Due Date</b> | <b>Discount Amount</b> | <b>Payable Amount</b> |                     |
| <a href="#">TAPS Murals 50% Deposit</a> | TAPS Grant - Manhole Mural Project CPSC            | 03/26/2026          | 03/26/2026      | 0.00                   | 3,000.00              |                     |

**Payment Register**

**APPKT01902 - 3/27/2026 AP**

| Vendor Number                          | Vendor Name                               |                     |                 |                        |                       | Total Vendor Amount        |
|--|---|---------------------|-----------------|------------------------|-----------------------|----------------------------|
| <a href="#">037920</a>                 | Goins Enterprises                         |                     |                 |                        |                       | 179,697.05                 |
| <b>Payment Type</b>                    | <b>Payment Number</b>                     |                     |                 | <b>Payment Date</b>    | <b>Payment Amount</b> |                            |
| EFT                                    | <a href="#">9473</a>                      |                     |                 | 03/27/2026             | 179,697.05            |                            |
| <b>Payable Number</b>                  | <b>Description</b>                        | <b>Payable Date</b> | <b>Due Date</b> | <b>Discount Amount</b> | <b>Payable Amount</b> |                            |
| <a href="#">Water Meter Pay App 12</a> | WATER METER/LINE REPL                     | 02/25/2026          | 03/27/2026      | 0.00                   | 179,697.05            |                            |
| <b>Vendor Number</b>                   | <b>Vendor Name</b>                        |                     |                 |                        |                       | <b>Total Vendor Amount</b> |
| <a href="#">036764</a>                 | H & H Roofing                             |                     |                 |                        |                       | 5,000.00                   |
| <b>Payment Type</b>                    | <b>Payment Number</b>                     |                     |                 | <b>Payment Date</b>    | <b>Payment Amount</b> |                            |
| Check                                  | <a href="#">80890</a>                     |                     |                 | 03/27/2026             | 5,000.00              |                            |
| <b>Payable Number</b>                  | <b>Description</b>                        | <b>Payable Date</b> | <b>Due Date</b> | <b>Discount Amount</b> | <b>Payable Amount</b> |                            |
| <a href="#">260013 F</a>               | Roof - 116 N 4th                          | 01/20/2026          | 02/19/2026      | 0.00                   | 5,000.00              |                            |
| <b>Vendor Number</b>                   | <b>Vendor Name</b>                        |                     |                 |                        |                       | <b>Total Vendor Amount</b> |
| <a href="#">010440</a>                 | Hugo's Industrial Supply                  |                     |                 |                        |                       | 1,002.86                   |
| <b>Payment Type</b>                    | <b>Payment Number</b>                     |                     |                 | <b>Payment Date</b>    | <b>Payment Amount</b> |                            |
| EFT                                    | <a href="#">9474</a>                      |                     |                 | 03/27/2026             | 1,002.86              |                            |
| <b>Payable Number</b>                  | <b>Description</b>                        | <b>Payable Date</b> | <b>Due Date</b> | <b>Discount Amount</b> | <b>Payable Amount</b> |                            |
| <a href="#">349139</a>                 | Folders                                   | 03/04/2026          | 04/03/2026      | 0.00                   | 159.76                |                            |
| <a href="#">349832</a>                 | Cleaning supplies                         | 03/19/2026          | 04/18/2026      | 0.00                   | 351.52                |                            |
| <a href="#">349939</a>                 | Toner                                     | 03/20/2026          | 04/19/2026      | 0.00                   | 295.66                |                            |
| <a href="#">349981</a>                 | HP toner black                            | 03/23/2026          | 04/22/2026      | 0.00                   | 170.12                |                            |
| <a href="#">349982</a>                 | Supplies                                  | 03/23/2026          | 04/22/2026      | 0.00                   | 25.80                 |                            |
| <b>Vendor Number</b>                   | <b>Vendor Name</b>                        |                     |                 |                        |                       | <b>Total Vendor Amount</b> |
| <a href="#">038354</a>                 | Hyspeco, Inc                              |                     |                 |                        |                       | 1,517.70                   |
| <b>Payment Type</b>                    | <b>Payment Number</b>                     |                     |                 | <b>Payment Date</b>    | <b>Payment Amount</b> |                            |
| Check                                  | <a href="#">80891</a>                     |                     |                 | 03/27/2026             | 1,517.70              |                            |
| <b>Payable Number</b>                  | <b>Description</b>                        | <b>Payable Date</b> | <b>Due Date</b> | <b>Discount Amount</b> | <b>Payable Amount</b> |                            |
| <a href="#">00933653</a>               | Hydraulic Hose Fittings                   | 03/13/2026          | 03/13/2026      | 0.00                   | 564.34                |                            |
| <a href="#">00935556</a>               | piping and coupler/nipple assemblies      | 03/19/2026          | 03/19/2026      | 0.00                   | 953.36                |                            |
| <b>Vendor Number</b>                   | <b>Vendor Name</b>                        |                     |                 |                        |                       | <b>Total Vendor Amount</b> |
| <a href="#">011180</a>                 | Independence Community                    |                     |                 |                        |                       | 5.00                       |
| <b>Payment Type</b>                    | <b>Payment Number</b>                     |                     |                 | <b>Payment Date</b>    | <b>Payment Amount</b> |                            |
| EFT                                    | <a href="#">9475</a>                      |                     |                 | 03/27/2026             | 5.00                  |                            |
| <b>Payable Number</b>                  | <b>Description</b>                        | <b>Payable Date</b> | <b>Due Date</b> | <b>Discount Amount</b> | <b>Payable Amount</b> |                            |
| <a href="#">INV0005264</a>             | Charitable Contribution - Employee Direct | 03/27/2026          | 03/27/2026      | 0.00                   | 5.00                  |                            |
| <b>Vendor Number</b>                   | <b>Vendor Name</b>                        |                     |                 |                        |                       | <b>Total Vendor Amount</b> |
| <a href="#">011211</a>                 | Independence Fire Fighter                 |                     |                 |                        |                       | 157.50                     |
| <b>Payment Type</b>                    | <b>Payment Number</b>                     |                     |                 | <b>Payment Date</b>    | <b>Payment Amount</b> |                            |
| EFT                                    | <a href="#">9476</a>                      |                     |                 | 03/27/2026             | 157.50                |                            |
| <b>Payable Number</b>                  | <b>Description</b>                        | <b>Payable Date</b> | <b>Due Date</b> | <b>Discount Amount</b> | <b>Payable Amount</b> |                            |
| <a href="#">INV0005266</a>             | Fire Insurance                            | 03/27/2026          | 03/27/2026      | 0.00                   | 157.50                |                            |
| <b>Vendor Number</b>                   | <b>Vendor Name</b>                        |                     |                 |                        |                       | <b>Total Vendor Amount</b> |
| <a href="#">033149</a>                 | Independence Firemen's Association        |                     |                 |                        |                       | 210.00                     |
| <b>Payment Type</b>                    | <b>Payment Number</b>                     |                     |                 | <b>Payment Date</b>    | <b>Payment Amount</b> |                            |
| EFT                                    | <a href="#">9477</a>                      |                     |                 | 03/27/2026             | 210.00                |                            |
| <b>Payable Number</b>                  | <b>Description</b>                        | <b>Payable Date</b> | <b>Due Date</b> | <b>Discount Amount</b> | <b>Payable Amount</b> |                            |
| <a href="#">INV0005265</a>             | Funding/ Firemen's Association            | 03/27/2026          | 03/27/2026      | 0.00                   | 210.00                |                            |
| <b>Vendor Number</b>                   | <b>Vendor Name</b>                        |                     |                 |                        |                       | <b>Total Vendor Amount</b> |
| <a href="#">037321</a>                 | Internal Revenue Service                  |                     |                 |                        |                       | 242.88                     |
| <b>Payment Type</b>                    | <b>Payment Number</b>                     |                     |                 | <b>Payment Date</b>    | <b>Payment Amount</b> |                            |
| Check                                  | <a href="#">80892</a>                     |                     |                 | 03/27/2026             | 242.88                |                            |
| <b>Payable Number</b>                  | <b>Description</b>                        | <b>Payable Date</b> | <b>Due Date</b> | <b>Discount Amount</b> | <b>Payable Amount</b> |                            |
| <a href="#">INV0005271</a>             | Tax Levy                                  | 03/27/2026          | 03/27/2026      | 0.00                   | 242.88                |                            |

**Payment Register**

**APPKT01902 - 3/27/2026 AP**

| Vendor Number                               | Vendor Name                               |                     |                 |                        |                       | Total Vendor Amount |
|---|---|---------------------|-----------------|------------------------|-----------------------|---------------------|
| <a href="#">036025</a>                      | Ironworks Welding And Fabrication         |                     |                 |                        |                       | 1,405.00            |
| <b>Payment Type</b>                         | <b>Payment Number</b>                     |                     |                 | <b>Payment Date</b>    | <b>Payment Amount</b> |                     |
| EFT   | <a href="#">9478</a>                      |                     |                 | 03/27/2026             | 1,405.00              |                     |
| <b>Payable Number</b>                       | <b>Description</b>                        | <b>Payable Date</b> | <b>Due Date</b> | <b>Discount Amount</b> | <b>Payable Amount</b> |                     |
| <a href="#">4202</a>                        | Equipment Repair                          | 02/23/2026          | 03/25/2026      | 0.00                   | 1,405.00              |                     |
| <a href="#">038372</a>                      | Kahrs Law Offices, P.A.                   |                     |                 |                        |                       | 357.40              |
| <b>Payment Type</b>                         | <b>Payment Number</b>                     |                     |                 | <b>Payment Date</b>    | <b>Payment Amount</b> |                     |
| Check                                       | <a href="#">80893</a>                     |                     |                 | 03/27/2026             | 357.40                |                     |
| <b>Payable Number</b>                       | <b>Description</b>                        | <b>Payable Date</b> | <b>Due Date</b> | <b>Discount Amount</b> | <b>Payable Amount</b> |                     |
| <a href="#">INV0005288</a>                  | [REDACTED]                                | 03/27/2026          | 03/27/2026      | 0.00                   | 357.40                |                     |
| <a href="#">032449</a>                      | Kansas Payment Center                     |                     |                 |                        |                       | 320.76              |
| <b>Payment Type</b>                         | <b>Payment Number</b>                     |                     |                 | <b>Payment Date</b>    | <b>Payment Amount</b> |                     |
| Check                                       | <a href="#">80894</a>                     |                     |                 | 03/27/2026             | 320.76                |                     |
| <b>Payable Number</b>                       | <b>Description</b>                        | <b>Payable Date</b> | <b>Due Date</b> | <b>Discount Amount</b> | <b>Payable Amount</b> |                     |
| <a href="#">INV0005284</a>                  | [REDACTED]                                | 03/27/2026          | 03/27/2026      | 0.00                   | 144.92                |                     |
| <a href="#">INV0005285</a>                  | [REDACTED]                                | 03/27/2026          | 03/27/2026      | 0.00                   | 84.92                 |                     |
| <a href="#">INV0005286</a>                  | [REDACTED]                                | 03/27/2026          | 03/27/2026      | 0.00                   | 90.92                 |                     |
| <a href="#">037823</a>                      | Koehn Construction Services               |                     |                 |                        |                       | 131,365.43          |
| <b>Payment Type</b>                         | <b>Payment Number</b>                     |                     |                 | <b>Payment Date</b>    | <b>Payment Amount</b> |                     |
| EFT   | <a href="#">9479</a>                      |                     |                 | 03/27/2026             | 131,365.43            |                     |
| <b>Payable Number</b>                       | <b>Description</b>                        | <b>Payable Date</b> | <b>Due Date</b> | <b>Discount Amount</b> | <b>Payable Amount</b> |                     |
| <a href="#">Rainbow Dr Sanitary Sewer f</a> | Rainbow Drive Sanitary Sewer Installation | 02/09/2026          | 03/11/2026      | 0.00                   | 35,097.78             |                     |
| <a href="#">Rainbow Dr Sanitary Sewer f</a> | Rainbow Drive Sanitary Sewer Installation | 03/03/2026          | 04/02/2026      | 0.00                   | 96,267.65             |                     |
| <a href="#">032158</a>                      | Kone, Inc.                                |                     |                 |                        |                       | 12,545.24           |
| <b>Payment Type</b>                         | <b>Payment Number</b>                     |                     |                 | <b>Payment Date</b>    | <b>Payment Amount</b> |                     |
| EFT   | <a href="#">9480</a>                      |                     |                 | 03/27/2026             | 12,545.24             |                     |
| <b>Payable Number</b>                       | <b>Description</b>                        | <b>Payable Date</b> | <b>Due Date</b> | <b>Discount Amount</b> | <b>Payable Amount</b> |                     |
| <a href="#">1159015031</a>                  | Repairs                                   | 10/06/2025          | 11/05/2025      | 0.00                   | 2,686.00              |                     |
| <a href="#">1159097241</a>                  | Repairs                                   | 02/26/2026          | 03/28/2026      | 0.00                   | 2,686.00              |                     |
| <a href="#">871960076</a>                   | Elevator                                  | 03/01/2026          | 03/31/2026      | 0.00                   | 7,173.24              |                     |
| <a href="#">035478</a>                      | Lochner, H.W. Inc.                        |                     |                 |                        |                       | 7,000.00            |
| <b>Payment Type</b>                         | <b>Payment Number</b>                     |                     |                 | <b>Payment Date</b>    | <b>Payment Amount</b> |                     |
| EFT   | <a href="#">9481</a>                      |                     |                 | 03/27/2026             | 7,000.00              |                     |
| <b>Payable Number</b>                       | <b>Description</b>                        | <b>Payable Date</b> | <b>Due Date</b> | <b>Discount Amount</b> | <b>Payable Amount</b> |                     |
| <a href="#">T00221584-5</a>                 | Rehabilitate Textron Apron Design         | 03/02/2026          | 04/01/2026      | 0.00                   | 7,000.00              |                     |
| <a href="#">034298</a>                      | Mid-American Research Chemical            |                     |                 |                        |                       | 7,473.97            |
| <b>Payment Type</b>                         | <b>Payment Number</b>                     |                     |                 | <b>Payment Date</b>    | <b>Payment Amount</b> |                     |
| EFT   | <a href="#">9482</a>                      |                     |                 | 03/27/2026             | 7,473.97              |                     |
| <b>Payable Number</b>                       | <b>Description</b>                        | <b>Payable Date</b> | <b>Due Date</b> | <b>Discount Amount</b> | <b>Payable Amount</b> |                     |
| <a href="#">0873110-IN</a>                  | Weed/bug killer and weather prevention    | 03/12/2026          | 04/11/2026      | 0.00                   | 7,473.97              |                     |
| <a href="#">038367</a>                      | MoboTrex, LLC                             |                     |                 |                        |                       | 1,159.00            |
| <b>Payment Type</b>                         | <b>Payment Number</b>                     |                     |                 | <b>Payment Date</b>    | <b>Payment Amount</b> |                     |
| Check                                       | <a href="#">80895</a>                     |                     |                 | 03/27/2026             | 1,159.00              |                     |
| <b>Payable Number</b>                       | <b>Description</b>                        | <b>Payable Date</b> | <b>Due Date</b> | <b>Discount Amount</b> | <b>Payable Amount</b> |                     |
| <a href="#">288885</a>                      | Pedestrian Cross Walk                     | 02/12/2026          | 02/12/2026      | 0.00                   | 1,159.00              |                     |

Payment Register

APPKT01902 - 3/27/2026 AP

| Vendor Number               | Vendor Name                              |                     |                 |                        |                       | Total Vendor Amount   |
|-----------------------------|--|---------------------|-----------------|------------------------|-----------------------|-----------------------|
| <a href="#">027225</a>      | Oil Patch Pump & Supply Inc.             |                     |                 |                        |                       | 3,250.00              |
| <b>Payment Type</b>         | <b>Payment Number</b>                    |                     |                 | <b>Payment Date</b>    |                       | <b>Payment Amount</b> |
| EFT                         | <a href="#">9483</a>                     |                     |                 | 03/27/2026             |                       | 3,250.00              |
| <b>Payable Number</b>       | <b>Description</b>                       | <b>Payable Date</b> | <b>Due Date</b> | <b>Discount Amount</b> | <b>Payable Amount</b> |                       |
| <a href="#">3006918</a>     | Rope Wire                                | 03/11/2026          | 04/10/2026      | 0.00                   | 3,250.00              |                       |
| <a href="#">038375</a>      | Omar Elshabassey                         |                     |                 |                        |                       | 4,672.49              |
| <b>Payment Type</b>         | <b>Payment Number</b>                    |                     |                 | <b>Payment Date</b>    |                       | <b>Payment Amount</b> |
| Check                       | <a href="#">80896</a>                    |                     |                 | 03/27/2026             |                       | 4,672.49              |
| <b>Payable Number</b>       | <b>Description</b>                       | <b>Payable Date</b> | <b>Due Date</b> | <b>Discount Amount</b> | <b>Payable Amount</b> |                       |
| <a href="#">INV0005304</a>  | Neighborhood Ext Grant Reim - 400 N 10th | 03/23/2026          | 03/23/2026      | 0.00                   | 4,672.49              |                       |
| <a href="#">036608</a>      | One Stop Pack N Ship                     |                     |                 |                        |                       | 75.89                 |
| <b>Payment Type</b>         | <b>Payment Number</b>                    |                     |                 | <b>Payment Date</b>    |                       | <b>Payment Amount</b> |
| Check                       | <a href="#">80897</a>                    |                     |                 | 03/27/2026             |                       | 75.89                 |
| <b>Payable Number</b>       | <b>Description</b>                       | <b>Payable Date</b> | <b>Due Date</b> | <b>Discount Amount</b> | <b>Payable Amount</b> |                       |
| <a href="#">82835</a>       | Mailings                                 | 03/12/2026          | 04/11/2026      | 0.00                   | 75.89                 |                       |
| <a href="#">018120</a>      | O'Reilly Auto Parts                      |                     |                 |                        |                       | 249.26                |
| <b>Payment Type</b>         | <b>Payment Number</b>                    |                     |                 | <b>Payment Date</b>    |                       | <b>Payment Amount</b> |
| Check                       | <a href="#">80898</a>                    |                     |                 | 03/27/2026             |                       | 249.26                |
| <b>Payable Number</b>       | <b>Description</b>                       | <b>Payable Date</b> | <b>Due Date</b> | <b>Discount Amount</b> | <b>Payable Amount</b> |                       |
| <a href="#">0154-301403</a> | F-450 and F-550 Filters                  | 03/05/2026          | 04/04/2026      | 0.00                   | 245.82                |                       |
| <a href="#">0154-302721</a> | Mini Lamp                                | 03/12/2026          | 04/11/2026      | 0.00                   | 3.44                  |                       |
| <a href="#">038152</a>      | Pappas Hayden Westberg & Jackson PC      |                     |                 |                        |                       | 498.79                |
| <b>Payment Type</b>         | <b>Payment Number</b>                    |                     |                 | <b>Payment Date</b>    |                       | <b>Payment Amount</b> |
| Check                       | <a href="#">80899</a>                    |                     |                 | 03/27/2026             |                       | 498.79                |
| <b>Payable Number</b>       | <b>Description</b>                       | <b>Payable Date</b> | <b>Due Date</b> | <b>Discount Amount</b> | <b>Payable Amount</b> |                       |
| <a href="#">INV0005289</a>  |  | 03/27/2026          | 03/27/2026      | 0.00                   | 498.79                |                       |
| <a href="#">034712</a>      | Prairie Fire Coffee & Roasters           |                     |                 |                        |                       | 67.90                 |
| <b>Payment Type</b>         | <b>Payment Number</b>                    |                     |                 | <b>Payment Date</b>    |                       | <b>Payment Amount</b> |
| EFT                         | <a href="#">9484</a>                     |                     |                 | 03/27/2026             |                       | 67.90                 |
| <b>Payable Number</b>       | <b>Description</b>                       | <b>Payable Date</b> | <b>Due Date</b> | <b>Discount Amount</b> | <b>Payable Amount</b> |                       |
| <a href="#">1722279</a>     | Coffee                                   | 03/11/2026          | 04/10/2026      | 0.00                   | 67.90                 |                       |
| <a href="#">036591</a>      | Premier Truck Group Of Tulsa             |                     |                 |                        |                       | 3,028.77              |
| <b>Payment Type</b>         | <b>Payment Number</b>                    |                     |                 | <b>Payment Date</b>    |                       | <b>Payment Amount</b> |
| Check                       | <a href="#">80900</a>                    |                     |                 | 03/27/2026             |                       | 3,028.77              |
| <b>Payable Number</b>       | <b>Description</b>                       | <b>Payable Date</b> | <b>Due Date</b> | <b>Discount Amount</b> | <b>Payable Amount</b> |                       |
| <a href="#">12589814</a>    | 603 Coolant Leak                         | 02/25/2026          | 03/27/2026      | 0.00                   | 1,316.77              |                       |
| <a href="#">12589815</a>    | 503 Check Engine Light                   | 02/27/2026          | 03/29/2026      | 0.00                   | 837.53                |                       |
| <a href="#">12590081</a>    | 416 Filter replacement                   | 03/13/2026          | 04/12/2026      | 0.00                   | 1,034.07              |                       |
| <a href="#">12590099</a>    | 602 Repair Credit                        | 03/03/2026          | 04/02/2026      | 0.00                   | -159.60               |                       |
| <a href="#">020010</a>      | Quality Motors Of Independence           |                     |                 |                        |                       | 357.64                |
| <b>Payment Type</b>         | <b>Payment Number</b>                    |                     |                 | <b>Payment Date</b>    |                       | <b>Payment Amount</b> |
| Check                       | <a href="#">80901</a>                    |                     |                 | 03/27/2026             |                       | 357.64                |
| <b>Payable Number</b>       | <b>Description</b>                       | <b>Payable Date</b> | <b>Due Date</b> | <b>Discount Amount</b> | <b>Payable Amount</b> |                       |
| <a href="#">194605</a>      | New key and transmission fluid check607  | 03/02/2026          | 04/01/2026      | 0.00                   | 357.64                |                       |

**Payment Register**

**APPKT01902 - 3/27/2026 AP**

| Vendor Number                | Vendor Name                           |                     |                 |                        |                       | Total Vendor Amount        |
|------------------------------|---------------------------------------|---------------------|-----------------|------------------------|-----------------------|----------------------------|
| <a href="#">037404</a>       | Red Tiger Tire & Auto Inc.            |                     |                 |                        |                       | 90.00                      |
| <b>Payment Type</b>          | <b>Payment Number</b>                 |                     |                 | <b>Payment Date</b>    | <b>Payment Amount</b> |                            |
| EFT                          | <a href="#">9485</a>                  |                     |                 | 03/27/2026             | 90.00                 |                            |
| <b>Payable Number</b>        | <b>Description</b>                    | <b>Payable Date</b> | <b>Due Date</b> | <b>Discount Amount</b> | <b>Payable Amount</b> |                            |
| <a href="#">12515</a>        | 442 Oil CHange and Tire roatation     | 03/12/2026          | 04/11/2026      | 0.00                   | 90.00                 |                            |
| <b>Vendor Number</b>         | <b>Vendor Name</b>                    |                     |                 |                        |                       | <b>Total Vendor Amount</b> |
| <a href="#">038103</a>       | Royal Refuse Recycling                |                     |                 |                        |                       | 1,490.00                   |
| <b>Payment Type</b>          | <b>Payment Number</b>                 |                     |                 | <b>Payment Date</b>    | <b>Payment Amount</b> |                            |
| Check                        | <a href="#">80902</a>                 |                     |                 | 03/27/2026             | 1,490.00              |                            |
| <b>Payable Number</b>        | <b>Description</b>                    | <b>Payable Date</b> | <b>Due Date</b> | <b>Discount Amount</b> | <b>Payable Amount</b> |                            |
| <a href="#">00030110036</a>  | Wire Ties and Hose Rack               | 03/23/2026          | 04/22/2026      | 0.00                   | 1,490.00              |                            |
| <b>Vendor Number</b>         | <b>Vendor Name</b>                    |                     |                 |                        |                       | <b>Total Vendor Amount</b> |
| <a href="#">033887</a>       | SMC Electric Supply                   |                     |                 |                        |                       | 100.85                     |
| <b>Payment Type</b>          | <b>Payment Number</b>                 |                     |                 | <b>Payment Date</b>    | <b>Payment Amount</b> |                            |
| Check                        | <a href="#">80903</a>                 |                     |                 | 03/27/2026             | 100.85                |                            |
| <b>Payable Number</b>        | <b>Description</b>                    | <b>Payable Date</b> | <b>Due Date</b> | <b>Discount Amount</b> | <b>Payable Amount</b> |                            |
| <a href="#">51086096-00</a>  | CC TD Fuse                            | 03/18/2026          | 04/17/2026      | 0.00                   | 100.85                |                            |
| <b>Vendor Number</b>         | <b>Vendor Name</b>                    |                     |                 |                        |                       | <b>Total Vendor Amount</b> |
| <a href="#">037393</a>       | Syn-Tech Systems, Inc.                |                     |                 |                        |                       | 186.23                     |
| <b>Payment Type</b>          | <b>Payment Number</b>                 |                     |                 | <b>Payment Date</b>    | <b>Payment Amount</b> |                            |
| Check                        | <a href="#">80904</a>                 |                     |                 | 03/27/2026             | 186.23                |                            |
| <b>Payable Number</b>        | <b>Description</b>                    | <b>Payable Date</b> | <b>Due Date</b> | <b>Discount Amount</b> | <b>Payable Amount</b> |                            |
| <a href="#">329270</a>       | Firmware                              | 02/06/2026          | 03/08/2026      | 0.00                   | 186.23                |                            |
| <b>Vendor Number</b>         | <b>Vendor Name</b>                    |                     |                 |                        |                       | <b>Total Vendor Amount</b> |
| <a href="#">034515</a>       | Tidy Whitie's Laundromat              |                     |                 |                        |                       | 12.61                      |
| <b>Payment Type</b>          | <b>Payment Number</b>                 |                     |                 | <b>Payment Date</b>    | <b>Payment Amount</b> |                            |
| EFT                          | <a href="#">9486</a>                  |                     |                 | 03/27/2026             | 12.61                 |                            |
| <b>Payable Number</b>        | <b>Description</b>                    | <b>Payable Date</b> | <b>Due Date</b> | <b>Discount Amount</b> | <b>Payable Amount</b> |                            |
| <a href="#">7117</a>         | Wash and Fold                         | 03/17/2026          | 04/16/2026      | 0.00                   | 12.61                 |                            |
| <b>Vendor Number</b>         | <b>Vendor Name</b>                    |                     |                 |                        |                       | <b>Total Vendor Amount</b> |
| <a href="#">038037</a>       | Trident Partnerships LLC              |                     |                 |                        |                       | 12,500.00                  |
| <b>Payment Type</b>          | <b>Payment Number</b>                 |                     |                 | <b>Payment Date</b>    | <b>Payment Amount</b> |                            |
| EFT                          | <a href="#">9487</a>                  |                     |                 | 03/27/2026             | 12,500.00             |                            |
| <b>Payable Number</b>        | <b>Description</b>                    | <b>Payable Date</b> | <b>Due Date</b> | <b>Discount Amount</b> | <b>Payable Amount</b> |                            |
| <a href="#">INV0005305</a>   | Downtown Building Grant - 113 E. Main | 03/24/2026          | 03/24/2026      | 0.00                   | 12,500.00             |                            |
| <b>Vendor Number</b>         | <b>Vendor Name</b>                    |                     |                 |                        |                       | <b>Total Vendor Amount</b> |
| <a href="#">024530</a>       | Tri-State Electric Supply             |                     |                 |                        |                       | 88.74                      |
| <b>Payment Type</b>          | <b>Payment Number</b>                 |                     |                 | <b>Payment Date</b>    | <b>Payment Amount</b> |                            |
| EFT                          | <a href="#">9488</a>                  |                     |                 | 03/27/2026             | 88.74                 |                            |
| <b>Payable Number</b>        | <b>Description</b>                    | <b>Payable Date</b> | <b>Due Date</b> | <b>Discount Amount</b> | <b>Payable Amount</b> |                            |
| <a href="#">1122-1018486</a> | LED Lamp                              | 03/10/2026          | 04/09/2026      | 0.00                   | 88.74                 |                            |
| <b>Vendor Number</b>         | <b>Vendor Name</b>                    |                     |                 |                        |                       | <b>Total Vendor Amount</b> |
| <a href="#">036512</a>       | US Cellular                           |                     |                 |                        |                       | 175.02                     |
| <b>Payment Type</b>          | <b>Payment Number</b>                 |                     |                 | <b>Payment Date</b>    | <b>Payment Amount</b> |                            |
| Check                        | <a href="#">80905</a>                 |                     |                 | 03/27/2026             | 175.02                |                            |
| <b>Payable Number</b>        | <b>Description</b>                    | <b>Payable Date</b> | <b>Due Date</b> | <b>Discount Amount</b> | <b>Payable Amount</b> |                            |
| <a href="#">0795283987</a>   | Code Enforcement Monthly Charges      | 03/10/2026          | 04/09/2026      | 0.00                   | 43.79                 |                            |
| <a href="#">0795294803</a>   | Sanitation Monthly Charges            | 03/10/2026          | 04/09/2026      | 0.00                   | 38.99                 |                            |
| <a href="#">0795421636</a>   | Water/Sewer Monthly Charges           | 03/10/2026          | 04/09/2026      | 0.00                   | 39.08                 |                            |
| <a href="#">0795463003</a>   | Street Monthly Charges                | 03/10/2026          | 04/09/2026      | 0.00                   | 53.16                 |                            |

**Payment Register**

**APPKT01902 - 3/27/2026 AP**

| Vendor Number              | Vendor Name                                       |                     |                 |                        |                       | Total Vendor Amount        |
|----------------------------|---|---------------------|-----------------|------------------------|-----------------------|----------------------------|
| <a href="#">038182</a>     | Vogelsang USA, Ltd.                               |                     |                 |                        |                       | 3,056.35                   |
| <b>Payment Type</b>        | <b>Payment Number</b>                             |                     |                 | <b>Payment Date</b>    |                       | <b>Payment Amount</b>      |
| EFT                        | <a href="#">9489</a>                              |                     |                 | 03/27/2026             |                       | 3,056.35                   |
| <b>Payable Number</b>      | <b>Description</b>                                | <b>Payable Date</b> | <b>Due Date</b> | <b>Discount Amount</b> | <b>Payable Amount</b> |                            |
| <a href="#">50021539-2</a> | Sewage Grinder Pump                               | 03/12/2026          | 03/12/2026      | 0.00                   | 3,056.35              |                            |
| <b>Vendor Number</b>       | <b>Vendor Name</b>                                |                     |                 |                        |                       | <b>Total Vendor Amount</b> |
| <a href="#">035913</a>     | Waters Hardware                                   |                     |                 |                        |                       | 3,184.00                   |
| <b>Payment Type</b>        | <b>Payment Number</b>                             |                     |                 | <b>Payment Date</b>    |                       | <b>Payment Amount</b>      |
| EFT                        | <a href="#">9490</a>                              |                     |                 | 03/27/2026             |                       | 3,184.00                   |
| <b>Payable Number</b>      | <b>Description</b>                                | <b>Payable Date</b> | <b>Due Date</b> | <b>Discount Amount</b> | <b>Payable Amount</b> |                            |
| <a href="#">8858/P</a>     | Cust no 72183 - Jefferson Subdivision Dishwashers | 03/25/2026          | 04/24/2026      | 0.00                   | 3,184.00              |                            |
| <b>Vendor Number</b>       | <b>Vendor Name</b>                                |                     |                 |                        |                       | <b>Total Vendor Amount</b> |
| <a href="#">034744</a>     | Woods Lumber Company                              |                     |                 |                        |                       | 17.98                      |
| <b>Payment Type</b>        | <b>Payment Number</b>                             |                     |                 | <b>Payment Date</b>    |                       | <b>Payment Amount</b>      |
| EFT                        | <a href="#">9491</a>                              |                     |                 | 03/27/2026             |                       | 17.98                      |
| <b>Payable Number</b>      | <b>Description</b>                                | <b>Payable Date</b> | <b>Due Date</b> | <b>Discount Amount</b> | <b>Payable Amount</b> |                            |
| <a href="#">634628</a>     | Nuts, bolts, screws                               | 03/10/2026          | 04/09/2026      | 0.00                   | 17.98                 |                            |
| <b>Vendor Number</b>       | <b>Vendor Name</b>                                |                     |                 |                        |                       | <b>Total Vendor Amount</b> |
| <a href="#">037036</a>     | Zinser Electric LLC                               |                     |                 |                        |                       | 1,585.00                   |
| <b>Payment Type</b>        | <b>Payment Number</b>                             |                     |                 | <b>Payment Date</b>    |                       | <b>Payment Amount</b>      |
| EFT                        | <a href="#">9492</a>                              |                     |                 | 03/27/2026             |                       | 1,585.00                   |
| <b>Payable Number</b>      | <b>Description</b>                                | <b>Payable Date</b> | <b>Due Date</b> | <b>Discount Amount</b> | <b>Payable Amount</b> |                            |
| <a href="#">3205</a>       | WWTP Monitoring Service                           | 04/01/2026          | 05/01/2026      | 0.00                   | 75.00                 |                            |
| <a href="#">3206</a>       | Quarterly Monitoring Service Enterprise Dr        | 04/01/2026          | 05/01/2026      | 0.00                   | 165.00                |                            |
| <a href="#">3213</a>       | Camera Installation                               | 03/19/2026          | 04/18/2026      | 0.00                   | 1,345.00              |                            |

### Payment Summary

| Bank Code             | Type              | Payable<br>Count | Payment<br>Count | Discount    | Payment           |
|-----------------------|-------------------|------------------|------------------|-------------|-------------------|
| General               | Check             | 37               | 22               | 0.00        | 121,724.47        |
| General               | EFT               | 64               | 34               | 0.00        | 455,876.88        |
| General               | Voided **Void EFT | 0                | 1                | 0.00        | 0.00              |
| <b>Packet Totals:</b> |                   | <b>101</b>       | <b>57</b>        | <b>0.00</b> | <b>577,601.35</b> |

### Cash Fund Summary

| Fund                  | Name        | Amount             |
|-----------------------|-------------|--------------------|
| 099                   | Pooled Cash | -577,601.35        |
| <b>Packet Totals:</b> |             | <b>-577,601.35</b> |



City of Independence

# Payment Register

APPKT01921 - 3/31/2026 AP  
01 - City of Independence

**Bank:** General - Community National Bank

|                            |                                     |                     |                       |  |
|----------------------------|-------------------------------------|---------------------|-----------------------|--|
| <b>Vendor Number</b>       | <b>Vendor Name</b>                  |                     |                       | <b>Total Vendor Amount</b>                   |
| <a href="#">035314</a>     | Montgomery County Register Of Deeds |                     |                       | 72.00  |
| <b>Payment Type</b>        | <b>Payment Number</b>               | <b>Payment Date</b> | <b>Payment Amount</b> |  |
| Check                      | <a href="#">80906</a>               | 03/31/2026          | 72.00                 |  |
| <b>Payable Number</b>      | <b>Description</b>                  | <b>Payable Date</b> | <b>Due Date</b>       | <b>Discount Amount</b> <b>Payable Amount</b> |
| <a href="#">INV0005321</a> | Lot Tie agreement                   | 03/31/2026          | 04/30/2026            | 0.00 72.00                                   |

### Payment Summary

| Bank Code             | Type  | Payable<br>Count | Payment<br>Count | Discount    | Payment      |
|-----------------------|-------|------------------|------------------|-------------|--------------|
| General               | Check | 1                | 1                | 0.00        | 72.00        |
| <b>Packet Totals:</b> |       | <b>1</b>         | <b>1</b>         | <b>0.00</b> | <b>72.00</b> |

### Cash Fund Summary

| Fund                  | Name        | Amount        |
|-----------------------|-------------|---------------|
| 099                   | Pooled Cash | -72.00        |
| <b>Packet Totals:</b> |             | <b>-72.00</b> |

MARCH 2026 DRAFT

\$ 1,001,284.28



City of Independence

# Vendor History Report By Vendor Name

Posting Date Range 03/31/2026 - 03/31/2026

Payment Date Range -

| Payable Number                               | Description                       | Units | Price    | Post Date | 1099 Account Number | Payment Number | Payment Date                      | Amount           | Shipping Dist Amount | Tax         | Discount    | Net              | Payment          |
|--|-----------------------------------|-------|----------|-----------|---------------------|----------------|-----------------------------------|------------------|----------------------|-------------|-------------|------------------|------------------|
| <b>Vendor Set: 01 - City of Independence</b> |                                   |       |          |           |                     |                |                                   |                  |                      |             |             |                  |                  |
| <b>037209 - First National Bank Of Omaha</b> |                                   |       |          |           |                     |                |                                   | <b>38,064.89</b> | <b>72.72</b>         | <b>0.00</b> | <b>0.00</b> | <b>38,137.61</b> | <b>38,137.61</b> |
| 000176682                                    | flower beds                       |       |          | 3/31/2026 |                     | DFT0006275     | 3/31/2026                         | 50.43            | 0.00                 | 0.00        | 0.00        | 50.43            | 50.43            |
|  | flower beds                       | 1.00  | 50.43    | 50.43     | 001-041-70220       |                | Grounds Repair & Maintenance Suj  | 50.43            |                      |             |             |                  |                  |
| 000176682 CM                                 | tax and random charge refund      |       |          | 3/31/2026 |                     | DFT0006261     | 3/31/2026                         | -3.62            | 0.00                 | 0.00        | 0.00        | -3.62            | -3.62            |
|  | tax and random charge             | -1.00 | 3.62     | -3.62     | 001-041-70220       |                | Grounds Repair & Maintenance Suj  | -3.62            |                      |             |             |                  |                  |
| 000176682-2                                  | additional shipping charge        |       |          | 3/31/2026 |                     | DFT0006262     | 3/31/2026                         | 1.14             | 0.00                 | 0.00        | 0.00        | 1.14             | 1.14             |
|  | additional shipping char          | 0.00  | 0.00     | 1.14      | 001-041-70220       |                | Grounds Repair & Maintenance Suj  | 1.14             |                      |             |             |                  |                  |
| 0003-1                                       | Safety Lunch                      |       |          | 3/31/2026 |                     | DFT0006387     | 3/31/2026                         | 75.26            | 0.00                 | 0.00        | 0.00        | 75.26            | 75.26            |
|  | Safety Lunch                      | 1.00  | 75.26    | 75.26     | 033-064-60740       |                | Safety/First Aid                  | 75.26            |                      |             |             |                  |                  |
| 004013750                                    | CPR Class Supplies and Cards      |       |          | 3/31/2026 |                     | DFT0006364     | 3/31/2026                         | 1,125.00         | 0.00                 | 0.00        | 0.00        | 1,125.00         | 1,125.00         |
|  | CPR Class Supplies and C          | 1.00  | 1,125.00 | 1,125.00  | 072-026-70000       |                | Other Operational Supplies        | 1,125.00         |                      |             |             |                  |                  |
| 00625-3365                                   | F250 Oil Change                   |       |          | 3/31/2026 |                     | DFT0006377     | 3/31/2026                         | 123.98           | 0.00                 | 0.00        | 0.00        | 123.98           | 123.98           |
|  | F250 Oil Change                   | 0.00  | 0.00     | 123.98    | 031-066-60340       |                | Vehicle Repair & Maintenance      | 123.98           |                      |             |             |                  |                  |
| 00625-3591                                   | Curt Van Oil Change               |       |          | 3/31/2026 |                     | DFT0006379     | 3/31/2026                         | 181.96           | 0.00                 | 0.00        | 0.00        | 181.96           | 181.96           |
|  | Curt Van Oil Change               | 0.00  | 0.00     | 181.96    | 031-066-60340       |                | Vehicle Repair & Maintenance      | 181.96           |                      |             |             |                  |                  |
| 00625-3594                                   | Crown Vic Oil Change              |       |          | 3/31/2026 |                     | DFT0006378     | 3/31/2026                         | 165.31           | 0.00                 | 0.00        | 0.00        | 165.31           | 165.31           |
|  | Crown Vic Oil Change              | 0.00  | 0.00     | 165.31    | 031-066-60340       |                | Vehicle Repair & Maintenance      | 165.31           |                      |             |             |                  |                  |
| 0154-296555                                  | Vehicle cleaning supplies         |       |          | 3/31/2026 |                     | DFT0006255     | 3/31/2026                         | 56.45            | 0.00                 | 0.00        | 0.00        | 56.45            | 56.45            |
|  | Vehicle cleaning supplie          | 1.00  | 56.45    | 56.45     | 001-043-70240       |                | Vehicle Repair & Maintenance Supj | 56.45            |                      |             |             |                  |                  |
| 0154-298515                                  | Brake pads & rotor                |       |          | 3/31/2026 |                     | DFT0006256     | 3/31/2026                         | 174.98           | 0.00                 | 0.00        | 0.00        | 174.98           | 174.98           |
|  | Brake pads & rotor                | 1.00  | 174.98   | 174.98    | 001-043-70240       |                | Vehicle Repair & Maintenance Supj | 174.98           |                      |             |             |                  |                  |
| 03409 2026                                   | Anderson KNOA membership renewal  |       |          | 3/31/2026 |                     | DFT0006333     | 3/31/2026                         | 30.00            | 0.00                 | 0.00        | 0.00        | 30.00            | 30.00            |
|  | Anderson KNOA membe               | 0.00  | 0.00     | 30.00     | 001-021-60270       |                | Membership Dues                   | 30.00            |                      |             |             |                  |                  |
| 034177941                                    | Short sleeve polo for Auxiliary   |       |          | 3/31/2026 |                     | DFT0006293     | 3/31/2026                         | 21.74            | 3.49                 | 0.00        | 0.00        | 25.23            | 25.23            |
|  | Short sleeve polo for Au          | 1.00  | 21.74    | 25.23     | 001-021-70060       |                | Uniforms                          | 25.23            |                      |             |             |                  |                  |
| 03418 2026                                   | Smith KNOA membership renewal     |       |          | 3/31/2026 |                     | DFT0006334     | 3/31/2026                         | 30.00            | 0.00                 | 0.00        | 0.00        | 30.00            | 30.00            |
|  | Smith KNOA membersh               | 0.00  | 0.00     | 30.00     | 001-021-60270       |                | Membership Dues                   | 30.00            |                      |             |             |                  |                  |
| 03755878133961024522                         | Totes for Bunker Boots, Zip Ties  |       |          | 3/31/2026 |                     | DFT0006357     | 3/31/2026                         | 48.80            | 0.00                 | 0.00        | 0.00        | 48.80            | 48.80            |
|  | Totes for Bunker Boots,           | 1.00  | 48.80    | 48.80     | 001-026-70000       |                | Other Operational Supplies        | 48.80            |                      |             |             |                  |                  |
| 03950  | KNOA Member renewal - J. Anderson |       |          | 3/31/2026 |                     | DFT0006319     | 3/31/2026                         | 30.00            | 0.00                 | 0.00        | 0.00        | 30.00            | 30.00            |
|  | KNOA Member renewal               | 0.00  | 0.00     | 30.00     | 001-021-60270       |                | Membership Dues                   | 30.00            |                      |             |             |                  |                  |

**Vendor History Report**

Posting Date Range 03/31/2026 - 03/31/2026

| Payable Number       | Description                    | Post Date | 1099     | Payment Number | Payment Date                      | Amount      | Shipping | Tax  | Discount | Net      | Payment  |
|----------------------|--------------------------------|-----------|----------|----------------|-----------------------------------|-------------|----------|------|----------|----------|----------|
| Item Description     | Units                          | Price     | Amount   | Account Number | Account Name                      | Dist Amount |          |      |          |          |          |
| 04031351201379430116 | Garden supplies                | 3/31/2026 |          | DFT0006265     | 3/31/2026                         | 12.35       | 0.00     | 0.00 | 0.00     | 12.35    | 12.35    |
|                      | Garden supplies                | 1.00      | 12.35    | 001-041-70220  | Grounds Repair & Maintenance Suj  | 12.35       |          |      |          |          |          |
| 1000078219           | SEK Day on the Hill Hotel Room | 3/31/2026 |          | DFT0006340     | 3/31/2026                         | 201.19      | 0.00     | 0.00 | 0.00     | 201.19   | 201.19   |
|                      | SEK Day on the Hill Hote       | 1.00      | 201.19   | 979-070-60000  | Other Professional Services       | 201.19      |          |      |          |          |          |
| 1002049387           | Filters                        | 3/31/2026 |          | DFT0006389     | 3/31/2026                         | 402.15      | 0.00     | 0.00 | 0.00     | 402.15   | 402.15   |
|                      | Filters                        | 1.00      | 402.15   | 033-064-70240  | Vehicle Repair & Maintenance Supj | 402.15      |          |      |          |          |          |
| 1003117595           | Alpine Insecticide             | 3/31/2026 |          | DFT0006341     | 3/31/2026                         | 219.47      | 0.00     | 0.00 | 0.00     | 219.47   | 219.47   |
|                      | Alpine Insecticide             | 1.00      | 219.47   | 979-070-70220  | Grounds Repair & Maintenance Suj  | 219.47      |          |      |          |          |          |
| 1003117616           | Sticky Boards                  | 3/31/2026 |          | DFT0006338     | 3/31/2026                         | 41.99       | 0.00     | 0.00 | 0.00     | 41.99    | 41.99    |
|                      | Sticky Boards                  | 1.00      | 41.99    | 979-070-70000  | Other Operational Supplies        | 41.99       |          |      |          |          |          |
| 101471               | diets                          | 3/31/2026 |          | DFT0006477     | 3/31/2026                         | 214.85      | 0.00     | 0.00 | 0.00     | 214.85   | 214.85   |
|                      | diets                          | 1.00      | 214.85   | 001-042-70083  | Animal Food                       | 214.85      |          |      |          |          |          |
| 102161359            | Int Code Council               | 3/31/2026 |          | DFT0006393     | 3/31/2026                         | 25.05       | 0.00     | 0.00 | 0.00     | 25.05    | 25.05    |
|                      | Codes                          | 0.00      | 25.05    | 001-027-60000  | Other Professional Services       | 25.05       |          |      |          |          |          |
| 110269               | Chainsaw chains and chisels    | 3/31/2026 |          | DFT0006281     | 3/31/2026                         | 230.12      | 0.00     | 0.00 | 0.00     | 230.12   | 230.12   |
|                      | Chainsaw chains and ch         | 1.00      | 230.12   | 001-041-70230  | Equipment Repair & Maintenance !  | 230.12      |          |      |          |          |          |
| 111-0775241-7797828  | Headphones and Air Tag         | 3/31/2026 |          | DFT0006368     | 3/31/2026                         | 118.98      | 0.00     | 0.00 | 0.00     | 118.98   | 118.98   |
|                      | Bluetooth Headphones           | 1.00      | 99.00    | 033-063-70010  | Office Supplies                   | 99.00       |          |      |          |          |          |
|                      | Apple AirTag                   | 1.00      | 19.98    | 033-062-70230  | Equipment Repair & Maintenance !  | 19.98       |          |      |          |          |          |
| 111-1020545-1047461  | Dymo printer labels            | 3/31/2026 |          | DFT0006367     | 3/31/2026                         | 58.30       | 0.00     | 0.00 | 0.00     | 58.30    | 58.30    |
|                      | Dymo printer labels            | 1.00      | 58.30    | 033-063-70010  | Office Supplies                   | 58.30       |          |      |          |          |          |
| 111-2336012-7709049  | Pump Parts                     | 3/31/2026 |          | DFT0006369     | 3/31/2026                         | 152.43      | 0.00     | 0.00 | 0.00     | 152.43   | 152.43   |
|                      | Cam and Groove Suction         | 1.00      | 111.44   | 033-062-70100  | Other Small Tools & Equipment     | 111.44      |          |      |          |          |          |
|                      | MUSTBEE Round Hole S           | 1.00      | 40.99    | 033-062-70230  | Equipment Repair & Maintenance !  | 40.99       |          |      |          |          |          |
| 111-2631625-5023441  | scott office chair             | 3/31/2026 |          | DFT0006470     | 3/31/2026                         | 139.99      | 0.00     | 0.00 | 0.00     | 139.99   | 139.99   |
|                      | scott office chair             | 1.00      | 139.99   | 001-041-70100  | Other Small Tools & Equipment     | 139.99      |          |      |          |          |          |
| 111-3091003-1623416  | IT equipment                   | 3/31/2026 |          | DFT0006396     | 3/31/2026                         | 46.98       | 0.00     | 0.00 | 0.00     | 46.98    | 46.98    |
|                      | USB drives                     | 1.00      | 46.98    | 001-009-70010  | Office Supplies                   | 46.98       |          |      |          |          |          |
| 111-5797630-4933801  | Car wash brush and foam cannon | 3/31/2026 |          | DFT0006366     | 3/31/2026                         | 37.97       | 0.00     | 0.00 | 0.00     | 37.97    | 37.97    |
|                      | Car wash brush and foai        | 1.00      | 37.97    | 033-062-70240  | Vehicle Repair & Maintenance Supj | 37.97       |          |      |          |          |          |
| 111-6880103-9354660  | LED Shop Light                 | 3/31/2026 |          | DFT0006371     | 3/31/2026                         | 198.99      | 0.00     | 0.00 | 0.00     | 198.99   | 198.99   |
|                      | Shop Light                     | 1.00      | 198.99   | 033-062-70210  | Building Repair & Maintenance Sup | 198.99      |          |      |          |          |          |
| 111-7910074-4759465  | Office chair                   | 3/31/2026 |          | DFT0006370     | 3/31/2026                         | 179.16      | 0.00     | 0.00 | 0.00     | 179.16   | 179.16   |
|                      | Office chair                   | 1.00      | 179.16   | 033-063-70010  | Office Supplies                   | 179.16      |          |      |          |          |          |
| 112-0442886-7381841  | coolers for 4H building        | 3/31/2026 |          | DFT0006485     | 3/31/2026                         | 1,799.98    | 0.00     | 0.00 | 0.00     | 1,799.98 | 1,799.98 |
|                      | coolers for 4H                 | 1.00      | 1,799.98 | 001-041-60310  | Building Repair & Maintenance     | 1,799.98    |          |      |          |          |          |
| 112-3293586-7342667  | exhibit maint                  | 3/31/2026 |          | DFT0006456     | 3/31/2026                         | 48.72       | 0.00     | 0.00 | 0.00     | 48.72    | 48.72    |

**Vendor History Report**

Posting Date Range 03/31/2026 - 03/31/2026

| Payable Number            | Description                             | Post Date | 1099      | Payment Number | Payment Date                      | Amount      | Shipping | Tax  | Discount | Net    | Payment |
|---------------------------|---|-----------|-----------|----------------|-----------------------------------|-------------|----------|------|----------|--------|---------|
| Item Description          | Units                                   | Price     | Amount    | Account Number | Account Name                      | Dist Amount |          |      |          |        |         |
| exhibit maint             | 1.00                                    | 48.72     | 48.72     | 001-042-70220  | Grounds Repair & Maintenance Suj  | 48.72       |          |      |          |        |         |
| 112-3293586-7342667-2     | exhibit maint                           |           | 3/31/2026 | DFT0006468     | 3/31/2026                         | 137.81      | 0.00     | 0.00 | 0.00     | 137.81 | 137.81  |
| exhibit maint             | 1.00                                    | 137.81    | 137.81    | 001-042-70220  | Grounds Repair & Maintenance Suj  | 137.81      |          |      |          |        |         |
| 112-5798323-2808204       | diets                                   |           | 3/31/2026 | DFT0006448     | 3/31/2026                         | 29.95       | 0.00     | 0.00 | 0.00     | 29.95  | 29.95   |
| diets                     | 1.00                                    | 29.95     | 29.95     | 001-042-70083  | Animal Food                       | 29.95       |          |      |          |        |         |
| 112-7430745-2858603       | Lightbulbs                              |           | 3/31/2026 | DFT0006464     | 3/31/2026                         | 113.16      | 0.00     | 0.00 | 0.00     | 113.16 | 113.16  |
| Lightbulbs                | 1.00                                    | 113.16    | 113.16    | 001-042-70210  | Building Repair & Maintenance Sup | 113.16      |          |      |          |        |         |
| 112-8079959-9893853       | exhibit repair                          |           | 3/31/2026 | DFT0006453     | 3/31/2026                         | 45.98       | 0.00     | 0.00 | 0.00     | 45.98  | 45.98   |
| exhibit maint             | 1.00                                    | 45.98     | 45.98     | 001-042-70220  | Grounds Repair & Maintenance Suj  | 45.98       |          |      |          |        |         |
| 112-9866059-9459428       | cooler warranty                         |           | 3/31/2026 | DFT0006479     | 3/31/2026                         | 305.96      | 0.00     | 0.00 | 0.00     | 305.96 | 305.96  |
| cooler warranty           | 0.00                                    | 0.00      | 305.96    | 001-041-70210  | Building Repair & Maintenance Sup | 305.96      |          |      |          |        |         |
| 112-9899421-9075414       | coolers for Shelter House               |           | 3/31/2026 | DFT0006483     | 3/31/2026                         | 730.62      | 0.00     | 0.00 | 0.00     | 730.62 | 730.62  |
| coolers for Shelter Hous  | 1.00                                    | 730.62    | 730.62    | 001-041-70100  | Other Small Tools & Equipment     | 730.62      |          |      |          |        |         |
| 113-0588224-4621865       | Otterbox Case                           |           | 3/31/2026 | DFT0006394     | 3/31/2026                         | 20.28       | 0.00     | 0.00 | 0.00     | 20.28  | 20.28   |
| Otterbox Case             | 1.00                                    | 20.28     | 20.28     | 033-063-70100  | Other Small Tools & Equipment     | 20.28       |          |      |          |        |         |
| 113-0814528-8475446       | Printer ink                             |           | 3/31/2026 | DFT0006391     | 3/31/2026                         | 156.44      | 0.00     | 0.00 | 0.00     | 156.44 | 156.44  |
| Printer ink               | 1.00                                    | 156.44    | 156.44    | 033-061-70010  | Office Supplies                   | 156.44      |          |      |          |        |         |
| 113-1377013-6859465       | Oil Hose Reel                           |           | 3/31/2026 | DFT0006372     | 3/31/2026                         | 309.99      | 0.00     | 0.00 | 0.00     | 309.99 | 309.99  |
| Oil Hose Reel             | 1.00                                    | 309.99    | 309.99    | 033-062-70100  | Other Small Tools & Equipment     | 309.99      |          |      |          |        |         |
| 113-1428459-5987427       | Job Shirt for Brittney Landell          |           | 3/31/2026 | DFT0006358     | 3/31/2026                         | 69.99       | 0.00     | 0.00 | 0.00     | 69.99  | 69.99   |
| Job Shirt for Brittney La | 1.00                                    | 69.99     | 69.99     | 001-026-70060  | Uniforms                          | 69.99       |          |      |          |        |         |
| 113-2118780-9729803       | EMS pants for Brittney Landell          |           | 3/31/2026 | DFT0006360     | 3/31/2026                         | 148.50      | 0.00     | 0.00 | 0.00     | 148.50 | 148.50  |
| EMS pants for Brittney L  | 1.00                                    | 148.50    | 148.50    | 001-026-70060  | Uniforms                          | 148.50      |          |      |          |        |         |
| 113-3079396-9203413       | Mirrors for Engine 2, Vehicle Wash Soap |           | 3/31/2026 | DFT0006362     | 3/31/2026                         | 277.01      | 0.00     | 0.00 | 0.00     | 277.01 | 277.01  |
| Mirrors for Engine 2, Ve  | 1.00                                    | 277.01    | 277.01    | 001-026-70240  | Vehicle Repair & Maintenance Supj | 277.01      |          |      |          |        |         |
| 113-3281293-6796223       | Carburetor for Street Roller            |           | 3/31/2026 | DFT0006352     | 3/31/2026                         | 134.99      | 0.00     | 0.00 | 0.00     | 134.99 | 134.99  |
| Carburetor for Street Rc  | 1.00                                    | 134.99    | 134.99    | 001-033-70230  | Equipment Repair & Maintenance !  | 134.99      |          |      |          |        |         |
| 113-3595920-4329854       | Two Pairs of EMS pants for J. Garcia    |           | 3/31/2026 | DFT0006359     | 3/31/2026                         | 128.70      | 0.00     | 0.00 | 0.00     | 128.70 | 128.70  |
| Two Pairs of EMS pants    | 1.00                                    | 128.70    | 128.70    | 001-026-70060  | Uniforms                          | 128.70      |          |      |          |        |         |
| 113-3762088-6002609       | Herbicide                               |           | 3/31/2026 | DFT0006381     | 3/31/2026                         | 319.54      | 0.00     | 0.00 | 0.00     | 319.54 | 319.54  |
| Herbicide                 | 1.00                                    | 319.54    | 319.54    | 031-066-70220  | Grounds Repair & Maintenance Suj  | 319.54      |          |      |          |        |         |
| 113-4213283-1288269       | Dell Tower Desktop Computer             |           | 3/31/2026 | DFT0006395     | 3/31/2026                         | 969.98      | 0.00     | 0.00 | 0.00     | 969.98 | 969.98  |
| Dell Tower Desktop Con    | 1.00                                    | 969.98    | 969.98    | 033-063-70100  | Other Small Tools & Equipment     | 969.98      |          |      |          |        |         |
| 113-5612634-1494600       | Hinges                                  |           | 3/31/2026 | DFT0006446     | 3/31/2026                         | 12.99       | 0.00     | 0.00 | 0.00     | 12.99  | 12.99   |
| Hinges                    | 1.00                                    | 12.99     | 12.99     | 001-042-70210  | Building Repair & Maintenance Sup | 12.99       |          |      |          |        |         |
| 113-6183943-3005820       | Syringes                                |           | 3/31/2026 | DFT0006374     | 3/31/2026                         | 15.58       | 0.00     | 0.00 | 0.00     | 15.58  | 15.58   |
| Syringes                  | 1.00                                    | 15.58     | 15.58     | 031-066-70100  | Other Small Tools & Equipment     | 15.58       |          |      |          |        |         |

**Vendor History Report**

Posting Date Range 03/31/2026 - 03/31/2026

| Payable Number        | Description                          | Post Date | 1099   | Payment Number | Payment Date                      | Amount      | Shipping | Tax  | Discount | Net     | Payment |
|-----------------------|--------------------------------------|-----------|--------|----------------|-----------------------------------|-------------|----------|------|----------|---------|---------|
| Item Description      | Units                                | Price     | Amount | Account Number | Account Name                      | Dist Amount |          |      |          |         |         |
| 113-6596757-6168251   | Mower blades                         | 3/31/2026 |        | DFT0006254     | 3/31/2026                         | 168.00      | 0.00     | 0.00 | 0.00     | 168.00  | 168.00  |
|                       | Mower blades                         | 1.00      | 168.00 | 001-043-70230  | Equipment Repair & Maintenance    | 168.00      |          |      |          |         |         |
| 113-8268926-8865009   | Mower blades                         | 3/31/2026 |        | DFT0006257     | 3/31/2026                         | 225.90      | 0.00     | 0.00 | 0.00     | 225.90  | 225.90  |
|                       | Mower blades                         | 1.00      | 225.90 | 001-043-70230  | Equipment Repair & Maintenance    | 225.90      |          |      |          |         |         |
| 113-9924635-5634655   | Janitorial Cart                      | 3/31/2026 |        | DFT0006351     | 3/31/2026                         | 89.98       | 0.00     | 0.00 | 0.00     | 89.98   | 89.98   |
|                       | Janitorial Cart                      | 1.00      | 89.98  | 001-033-70020  | Janitorial Supplies               | 89.98       |          |      |          |         |         |
| 114-0790970-7976216   | playground equip repair              | 3/31/2026 |        | DFT0006270     | 3/31/2026                         | 26.45       | 0.00     | 0.00 | 0.00     | 26.45   | 26.45   |
|                       | playground equip repair              | 1.00      | 26.45  | 001-041-70230  | Equipment Repair & Maintenance    | 26.45       |          |      |          |         |         |
| 114-0923487-7540215   | Markers                              | 3/31/2026 |        | DFT0006408     | 3/31/2026                         | 23.55       | 0.00     | 0.00 | 0.00     | 23.55   | 23.55   |
|                       | Markers - Strategic Plan             | 1.00      | 23.55  | 001-001-70010  | Office Supplies                   | 23.55       |          |      |          |         |         |
| 114-0929042-1733811   | USB-C to DisplayPort                 | 3/31/2026 |        | DFT0006288     | 3/31/2026                         | 8.95        | 0.00     | 0.00 | 0.00     | 8.95    | 8.95    |
|                       | USB-C to DisplayPort                 | 1.00      | 8.95   | 001-021-70010  | Office Supplies                   | 8.95        |          |      |          |         |         |
| 114-1840259-6985025   | laptop stand and cord for printer    | 3/31/2026 |        | DFT0006294     | 3/31/2026                         | 26.13       | 0.00     | 0.00 | 0.00     | 26.13   | 26.13   |
|                       | laptop stand and cord fc             | 1.00      | 26.13  | 001-021-70010  | Office Supplies                   | 26.13       |          |      |          |         |         |
| 114-1956565-6397005CM | Refund for laptop sunscreens         | 3/31/2026 |        | DFT0006286     | 3/31/2026                         | -212.65     | 0.00     | 0.00 | 0.00     | -212.65 | -212.65 |
|                       | Refund for laptop sunsc              | -1.00     | 212.65 | 001-021-70000  | Other Operational Supplies        | -212.65     |          |      |          |         |         |
| 114-2238712-7204213   | Waders with boots                    | 3/31/2026 |        | DFT0006386     | 3/31/2026                         | 36.43       | 0.00     | 0.00 | 0.00     | 36.43   | 36.43   |
|                       | Waders with boots                    | 1.00      | 36.43  | 033-064-70060  | Uniforms                          | 36.43       |          |      |          |         |         |
| 114-2255207-1535434   | Printer for Bridgets office          | 3/31/2026 |        | DFT0006306     | 3/31/2026                         | 169.99      | 0.00     | 0.00 | 0.00     | 169.99  | 169.99  |
|                       | Printer for Bridgets offic           | 1.00      | 169.99 | 001-020-70100  | Other Small Tools & Equipment     | 169.99      |          |      |          |         |         |
| 114-3685016-9807426   | City Hall Vacuum                     | 3/31/2026 |        | DFT0006410     | 3/31/2026                         | 55.41       | 0.00     | 0.00 | 0.00     | 55.41   | 55.41   |
|                       | City Hall - Vacuum and g             | 1.00      | 55.41  | 001-004-70020  | Janitorial Supplies               | 55.41       |          |      |          |         |         |
| 114-3929191-5166666   | Pest Control Sprayer                 | 3/31/2026 |        | DFT0006344     | 3/31/2026                         | 358.80      | 0.00     | 0.00 | 0.00     | 358.80  | 358.80  |
|                       | Pest Control Sprayer                 | 1.00      | 358.80 | 982-070-70100  | Other Small Tools & Equipment     | 358.80      |          |      |          |         |         |
| 114-4039105-4063427   | Oil                                  | 3/31/2026 |        | DFT0006258     | 3/31/2026                         | 277.76      | 0.00     | 0.00 | 0.00     | 277.76  | 277.76  |
|                       | Oil                                  | 1.00      | 277.76 | 001-043-70230  | Equipment Repair & Maintenance    | 277.76      |          |      |          |         |         |
| 114-4091731-2108228   | Mem Hall - Gaffers Tape              | 3/31/2026 |        | DFT0006417     | 3/31/2026                         | 618.00      | 0.00     | 0.00 | 0.00     | 618.00  | 618.00  |
|                       | Gaffer Tape                          | 1.00      | 618.00 | 001-046-70210  | Building Repair & Maintenance Sup | 618.00      |          |      |          |         |         |
| 114-4249830-1522616   | USB-C to DislayPort for lab computer | 3/31/2026 |        | DFT0006287     | 3/31/2026                         | 7.99        | 0.00     | 0.00 | 0.00     | 7.99    | 7.99    |
|                       | USB-C to DislayPort for l            | 1.00      | 7.99   | 001-021-70010  | Office Supplies                   | 7.99        |          |      |          |         |         |
| 114-4935399-2760213   | Tires                                | 3/31/2026 |        | DFT0006259     | 3/31/2026                         | 309.98      | 0.00     | 0.00 | 0.00     | 309.98  | 309.98  |
|                       | Tires                                | 1.00      | 309.98 | 001-043-70230  | Equipment Repair & Maintenance    | 309.98      |          |      |          |         |         |
| 114-5750691-3263414   | Cassette Tape Adapter                | 3/31/2026 |        | DFT0006292     | 3/31/2026                         | 22.79       | 0.00     | 0.00 | 0.00     | 22.79   | 22.79   |
|                       | Cassette Tape Adapter                | 1.00      | 22.79  | 001-021-70100  | Other Small Tools & Equipment     | 22.79       |          |      |          |         |         |
| 114-5768548-6237065   | Batteries CR123A                     | 3/31/2026 |        | DFT0006299     | 3/31/2026                         | 69.58       | 0.00     | 0.00 | 0.00     | 69.58   | 69.58   |
|                       | Batteries CR123A                     | 2.00      | 34.79  | 001-021-70230  | Equipment Repair & Maintenance    | 69.58       |          |      |          |         |         |
| 114-6153865-6019424   | Strategic Plan Equipment             | 3/31/2026 |        | DFT0006411     | 3/31/2026                         | 105.41      | 0.00     | 0.00 | 0.00     | 105.41  | 105.41  |

**Vendor History Report**

Posting Date Range 03/31/2026 - 03/31/2026

| Payable Number           | Description                               | Post Date | 1099     | Payment Number | Payment Date                      | Amount      | Shipping | Tax  | Discount | Net      | Payment  |
|--------------------------|---|-----------|----------|----------------|-----------------------------------|-------------|----------|------|----------|----------|----------|
| Item Description         | Units                                     | Price     | Amount   | Account Number | Account Name                      | Dist Amount |          |      |          |          |          |
| Equipment for Strat. Pla | 1.00                                      | 105.41    | 105.41   | 001-001-70100  | Other Small Tools & Equipment     | 105.41      |          |      |          |          |          |
| 114-6423170-9012210      | Picture frames for promotion certificates | 3/31/2026 |          | DFT0006291     | 3/31/2026                         | 20.01       | 0.00     | 0.00 | 0.00     | 20.01    | 20.01    |
| Picture frames for prom  | 1.00                                      | 20.01     | 20.01    | 001-021-70010  | Office Supplies                   | 20.01       |          |      |          |          |          |
| 114-6784498-6377855      | playground equip repair                   | 3/31/2026 |          | DFT0006272     | 3/31/2026                         | 35.87       | 0.00     | 0.00 | 0.00     | 35.87    | 35.87    |
| playground equip repair  | 1.00                                      | 35.87     | 35.87    | 001-041-70230  | Equipment Repair & Maintenance !  | 35.87       |          |      |          |          |          |
| 114-7078140-6579454      | Amazaon - Tables                          | 3/31/2026 |          | DFT0006407     | 3/31/2026                         | 1,368.90    | 0.00     | 0.00 | 0.00     | 1,368.90 | 1,368.90 |
| Tables                   | 10.00                                     | 136.89    | 1,368.90 | 001-046-70100  | Other Small Tools & Equipment     | 1,368.90    |          |      |          |          |          |
| 114-7299931-9480252      | Batteries and Swiffer                     | 3/31/2026 |          | DFT0006415     | 3/31/2026                         | 183.32      | 0.00     | 0.00 | 0.00     | 183.32   | 183.32   |
| Janitorial City Hall     | 1.00                                      | 183.32    | 183.32   | 001-004-70020  | Janitorial Supplies               | 183.32      |          |      |          |          |          |
| 114-7323482-7012237      | Quick Disconnect Spade Terminal           | 3/31/2026 |          | DFT0006385     | 3/31/2026                         | 13.63       | 0.00     | 0.00 | 0.00     | 13.63    | 13.63    |
| Quick Disconnect Spade   | 1.00                                      | 13.63     | 13.63    | 033-064-70100  | Other Small Tools & Equipment     | 13.63       |          |      |          |          |          |
| 114-7601742-0893808      | Mem Hall Tables                           | 3/31/2026 |          | DFT0006418     | 3/31/2026                         | 684.45      | 0.00     | 0.00 | 0.00     | 684.45   | 684.45   |
| Tables                   | 1.00                                      | 684.45    | 684.45   | 001-046-70100  | Other Small Tools & Equipment     | 684.45      |          |      |          |          |          |
| 114-8437117-9621055      | Kitchen Carts                             | 3/31/2026 |          | DFT0006416     | 3/31/2026                         | 319.62      | 0.00     | 0.00 | 0.00     | 319.62   | 319.62   |
| Kitchen Carts            | 1.00                                      | 319.62    | 319.62   | 001-046-70100  | Other Small Tools & Equipment     | 319.62      |          |      |          |          |          |
| 114-9052447-7822631      | Docking station                           | 3/31/2026 |          | DFT0006314     | 3/31/2026                         | 394.99      | 3.99     | 0.00 | 0.00     | 398.98   | 398.98   |
| Docking station          | 1.00                                      | 394.99    | 398.98   | 001-021-70100  | Other Small Tools & Equipment     | 398.98      |          |      |          |          |          |
| 114-9204369-5545013      | Flip chart                                | 3/31/2026 |          | DFT0006414     | 3/31/2026                         | 178.15      | 0.00     | 0.00 | 0.00     | 178.15   | 178.15   |
| Easels                   | 1.00                                      | 178.15    | 178.15   | 001-001-70010  | Office Supplies                   | 178.15      |          |      |          |          |          |
| 114-9544842-8525016      | Disposable shoe covers                    | 3/31/2026 |          | DFT0006402     | 3/31/2026                         | 16.41       | 0.00     | 0.00 | 0.00     | 16.41    | 16.41    |
| Disposable shoe covers   | 1.00                                      | 16.41     | 16.41    | 001-027-70000  | Other Operational Supplies        | 16.41       |          |      |          |          |          |
| 117312774                | Toner and binder clips                    | 3/31/2026 |          | DFT0006308     | 3/31/2026                         | 187.33      | 0.00     | 0.00 | 0.00     | 187.33   | 187.33   |
| Toner and binder clips   | 1.00                                      | 187.33    | 187.33   | 001-021-70010  | Office Supplies                   | 187.33      |          |      |          |          |          |
| 117394140                | Toner                                     | 3/31/2026 |          | DFT0006315     | 3/31/2026                         | 519.26      | 0.00     | 0.00 | 0.00     | 519.26   | 519.26   |
| Toner                    | 1.00                                      | 519.26    | 519.26   | 001-021-70010  | Office Supplies                   | 519.26      |          |      |          |          |          |
| 117532959                | Misc Office supplies                      | 3/31/2026 |          | DFT0006307     | 3/31/2026                         | 184.95      | 0.00     | 0.00 | 0.00     | 184.95   | 184.95   |
| Misc Office supplies     | 1.00                                      | 184.95    | 184.95   | 001-021-70010  | Office Supplies                   | 184.95      |          |      |          |          |          |
| 1175-6777                | EFD                                       | 3/31/2026 |          | DFT0006318     | 3/31/2026                         | 30.00       | 0.00     | 0.00 | 0.00     | 30.00    | 30.00    |
| EFD                      | 0.00                                      | 0.00      | 30.00    | 008-020-60760  | Training                          | 30.00       |          |      |          |          |          |
| 1220                     | 3 Commercial Keys                         | 3/31/2026 |          | DFT0006390     | 3/31/2026                         | 14.00       | 0.00     | 0.00 | 0.00     | 14.00    | 14.00    |
| 3 Commercial Keys        | 1.00                                      | 14.00     | 14.00    | 033-061-70210  | Building Repair & Maintenance Sup | 14.00       |          |      |          |          |          |
| 13043292011589267374     | Document Protectors                       | 3/31/2026 |          | DFT0006373     | 3/31/2026                         | 5.74        | 0.00     | 0.00 | 0.00     | 5.74     | 5.74     |
| Document Protectors      | 1.00                                      | 5.74      | 5.74     | 031-066-70000  | Other Operational Supplies        | 5.74        |          |      |          |          |          |
| 13420511404198689018     | receipt book                              | 3/31/2026 |          | DFT0006441     | 3/31/2026                         | 3.88        | 0.00     | 0.00 | 0.00     | 3.88     | 3.88     |
| receipt book             | 1.00                                      | 3.88      | 3.88     | 001-042-70000  | Other Operational Supplies        | 3.88        |          |      |          |          |          |
| 134423                   | safety equip                              | 3/31/2026 |          | DFT0006264     | 3/31/2026                         | 8.49        | 0.00     | 0.00 | 0.00     | 8.49     | 8.49     |
| safety equip             | 1.00                                      | 8.49      | 8.49     | 001-041-60740  | Safety/First Aid                  | 8.49        |          |      |          |          |          |

**Vendor History Report**

**Posting Date Range 03/31/2026 - 03/31/2026**

| Payable Number       | Description                    | Post Date | 1099   | Payment Number | Payment Date                      | Amount      | Shipping | Tax  | Discount | Net    | Payment |
|----------------------|--------------------------------|-----------|--------|----------------|-----------------------------------|-------------|----------|------|----------|--------|---------|
| Item Description     | Units                          | Price     | Amount | Account Number | Account Name                      | Dist Amount |          |      |          |        |         |
| 13643693091582273374 | Trash bags, clear, coffee, etc | 3/31/2026 |        | DFT0006349     | 3/31/2026                         | 75.59       | 0.00     | 0.00 | 0.00     | 75.59  | 75.59   |
|                      | Trash bags, clear, coffee      | 1.00      | 75.59  | 001-020-70010  | Office Supplies                   |             | 75.59    |      |          |        |         |
| 136722               | diets                          | 3/31/2026 |        | DFT0006471     | 3/31/2026                         | 148.93      | 0.00     | 0.00 | 0.00     | 148.93 | 148.93  |
|                      | diets                          | 1.00      | 148.93 | 001-042-70083  | Animal Food                       |             | 148.93   |      |          |        |         |
| 137605               | Buckets                        | 3/31/2026 |        | DFT0006452     | 3/31/2026                         | 45.95       | 0.00     | 0.00 | 0.00     | 45.95  | 45.95   |
|                      | operational items              | 1.00      | 45.95  | 001-042-70100  | Other Small Tools & Equipment     |             | 45.95    |      |          |        |         |
| 138381               | Angle grinder                  | 3/31/2026 |        | DFT0006280     | 3/31/2026                         | 203.57      | 0.00     | 0.00 | 0.00     | 203.57 | 203.57  |
|                      | Angle grinder                  | 1.00      | 203.57 | 001-041-70100  | Other Small Tools & Equipment     |             | 203.57   |      |          |        |         |
| 138689               | exhibit maint                  | 3/31/2026 |        | DFT0006484     | 3/31/2026                         | 817.90      | 0.00     | 0.00 | 0.00     | 817.90 | 817.90  |
|                      | exhibit maint                  | 1.00      | 817.90 | 001-042-70220  | Grounds Repair & Maintenance Suj  |             | 817.90   |      |          |        |         |
| 138844               | Fencing supplies               | 3/31/2026 |        | DFT0006444     | 3/31/2026                         | 6.49        | 0.00     | 0.00 | 0.00     | 6.49   | 6.49    |
|                      | Fencing supplies               | 1.00      | 6.49   | 001-042-70220  | Grounds Repair & Maintenance Suj  |             | 6.49     |      |          |        |         |
| 139867               | Fence stretcher                | 3/31/2026 |        | DFT0006277     | 3/31/2026                         | 99.99       | 0.00     | 0.00 | 0.00     | 99.99  | 99.99   |
|                      | Fence stretcher                | 1.00      | 99.99  | 001-041-70100  | Other Small Tools & Equipment     |             | 99.99    |      |          |        |         |
| 139905               | Supplies                       | 3/31/2026 |        | DFT0006443     | 3/31/2026                         | 5.99        | 0.00     | 0.00 | 0.00     | 5.99   | 5.99    |
|                      | Supplies                       | 1.00      | 5.99   | 001-042-70000  | Other Operational Supplies        |             | 5.99     |      |          |        |         |
| 140623               | Poly Strainer                  | 3/31/2026 |        | DFT0006376     | 3/31/2026                         | 32.84       | 0.00     | 0.00 | 0.00     | 32.84  | 32.84   |
|                      | Poly Strainer                  | 1.00      | 32.84  | 031-066-70020  | Janitorial Supplies               |             | 32.84    |      |          |        |         |
| 14207969303          | KHRC LIHTC Training            | 3/31/2026 |        | DFT0006346     | 3/31/2026                         | 645.68      | 0.00     | 0.00 | 0.00     | 645.68 | 645.68  |
|                      | KHRC LIHTC Training            | 0.00      | 645.68 | 979-070-60000  | Other Professional Services       |             | 645.68   |      |          |        |         |
| 144384               | Tractor repair                 | 3/31/2026 |        | DFT0006463     | 3/31/2026                         | 110.00      | 0.00     | 0.00 | 0.00     | 110.00 | 110.00  |
|                      | Tractor repair                 | 0.00      | 110.00 | 001-042-60330  | Equipment Repair & Maintenance    |             | 110.00   |      |          |        |         |
| 1449                 | KAPIO Membership               | 3/31/2026 |        | DFT0006297     | 3/31/2026                         | 50.00       | 0.00     | 0.00 | 0.00     | 50.00  | 50.00   |
|                      | KAPIO Membership H. C          | 0.00      | 50.00  | 001-021-60270  | Membership Dues                   |             | 50.00    |      |          |        |         |
| 1504865488           | Storage unit rental B05 & A49  | 3/31/2026 |        | DFT0006312     | 3/31/2026                         | 305.00      | 0.00     | 0.00 | 0.00     | 305.00 | 305.00  |
|                      | Storage unit rental B05        | 0.00      | 305.00 | 001-021-60310  | Building Repair & Maintenance     |             | 305.00   |      |          |        |         |
| 151935446            | Tool Cage for Shop             | 3/31/2026 |        | DFT0006353     | 3/31/2026                         | 467.18      | 0.00     | 0.00 | 0.00     | 467.18 | 467.18  |
|                      | Tool Cage for Shop             | 1.00      | 467.18 | 001-033-70210  | Building Repair & Maintenance Suj |             | 467.18   |      |          |        |         |
| 152691               | Meal while picking up Alpaca   | 3/31/2026 |        | DFT0006449     | 3/31/2026                         | 30.46       | 0.00     | 0.00 | 0.00     | 30.46  | 30.46   |
|                      | Meal while picking up A        | 1.00      | 30.46  | 001-042-70000  | Other Operational Supplies        |             | 30.46    |      |          |        |         |
| 1541-9072            | EFD - S. Alspaugh retest       | 3/31/2026 |        | DFT0006295     | 3/31/2026                         | 30.00       | 0.00     | 0.00 | 0.00     | 30.00  | 30.00   |
|                      | EFD - S. Alspaugh retest       | 0.00      | 30.00  | 008-020-60760  | Training                          |             | 30.00    |      |          |        |         |
| 155326               | grass seed                     | 3/31/2026 |        | DFT0006278     | 3/31/2026                         | 102.93      | 0.00     | 0.00 | 0.00     | 102.93 | 102.93  |
|                      | grass seed                     | 1.00      | 102.93 | 001-041-70220  | Grounds Repair & Maintenance Suj  |             | 102.93   |      |          |        |         |
| 1573-0478            | KRWA Conference registrations  | 3/31/2026 |        | DFT0006392     | 3/31/2026                         | 480.00      | 0.00     | 0.00 | 0.00     | 480.00 | 480.00  |
|                      | KRWA Conference regis          | 0.00      | 480.00 | 033-061-60760  | Training                          |             | 480.00   |      |          |        |         |
| 1793-0997            | EFD recert - J. Gregory        | 3/31/2026 |        | DFT0006332     | 3/31/2026                         | 46.50       | 0.00     | 0.00 | 0.00     | 46.50  | 46.50   |

**Vendor History Report**

Posting Date Range 03/31/2026 - 03/31/2026

| Payable Number              | Description                          | Post Date | 1099      | Payment Number | Payment Date                      | Amount      | Shipping | Tax  | Discount | Net      | Payment  |
|-----------------------------|--------------------------------------|-----------|-----------|----------------|-----------------------------------|-------------|----------|------|----------|----------|----------|
| Item Description            | Units                                | Price     | Amount    | Account Number | Account Name                      | Dist Amount |          |      |          |          |          |
| EFD recert - J. Gregory     | 0.00                                 | 0.00      | 46.50     | 008-020-60760  | Training                          |             | 46.50    |      |          |          |          |
| 1E1D6BA0-0010               | Ring Camera                          |           | 3/31/2026 | DFT0006409     | 3/31/2026                         | 49.99       | 0.00     | 0.00 | 0.00     | 49.99    | 49.99    |
| Ring Camera City Hall       | 0.00                                 | 0.00      | 49.99     | 001-004-70000  | Other Operational Supplies        |             | 49.99    |      |          |          |          |
| 2000141-67281030            | diets                                |           | 3/31/2026 | DFT0006450     | 3/31/2026                         | 32.28       | 0.00     | 0.00 | 0.00     | 32.28    | 32.28    |
| diets                       | 1.00                                 | 32.28     | 32.28     | 001-042-70083  | Animal Food                       |             | 32.28    |      |          |          |          |
| 2000142-29516515            | diets                                |           | 3/31/2026 | DFT0006469     | 3/31/2026                         | 139.79      | 0.00     | 0.00 | 0.00     | 139.79   | 139.79   |
| diets                       | 1.00                                 | 139.79    | 139.79    | 001-042-70083  | Animal Food                       |             | 139.79   |      |          |          |          |
| 2000142-43414322            | File box                             |           | 3/31/2026 | DFT0006447     | 3/31/2026                         | 22.06       | 0.00     | 0.00 | 0.00     | 22.06    | 22.06    |
| File box                    | 1.00                                 | 22.06     | 22.06     | 001-042-70000  | Other Operational Supplies        |             | 9.94     |      |          |          |          |
|                             |                                      |           |           | 001-042-70210  | Building Repair & Maintenance Sup |             | 12.12    |      |          |          |          |
| 2000142-76187020            | sm tools                             |           | 3/31/2026 | DFT0006459     | 3/31/2026                         | 62.99       | 0.00     | 0.00 | 0.00     | 62.99    | 62.99    |
| sm tools                    | 1.00                                 | 62.99     | 62.99     | 001-042-70100  | Other Small Tools & Equipment     |             | 62.99    |      |          |          |          |
| 2000143-03272025            | diets and misc items                 |           | 3/31/2026 | DFT0006476     | 3/31/2026                         | 194.28      | 0.00     | 0.00 | 0.00     | 194.28   | 194.28   |
| diets and misc items        | 1.00                                 | 194.28    | 194.28    | 001-042-70000  | Other Operational Supplies        |             | 21.68    |      |          |          |          |
|                             |                                      |           |           | 001-042-70083  | Animal Food                       |             | 172.60   |      |          |          |          |
| 2000143-80024260            | diets                                |           | 3/31/2026 | DFT0006473     | 3/31/2026                         | 169.25      | 0.00     | 0.00 | 0.00     | 169.25   | 169.25   |
| diets                       | 1.00                                 | 169.25    | 169.25    | 001-042-70083  | Animal Food                       |             | 169.25   |      |          |          |          |
| 2000144-98245707            | diets                                |           | 3/31/2026 | DFT0006472     | 3/31/2026                         | 169.25      | 0.00     | 0.00 | 0.00     | 169.25   | 169.25   |
| diets                       | 1.00                                 | 169.25    | 169.25    | 001-042-70083  | Animal Food                       |             | 169.25   |      |          |          |          |
| 20104228844233794419        | Misc supplies                        |           | 3/31/2026 | DFT0006457     | 3/31/2026                         | 55.86       | 0.00     | 0.00 | 0.00     | 55.86    | 55.86    |
| Misc supplies               | 1.00                                 | 55.86     | 55.86     | 001-041-70000  | Other Operational Supplies        |             | 10.87    |      |          |          |          |
|                             |                                      |           |           | 001-042-70000  | Other Operational Supplies        |             | 44.99    |      |          |          |          |
| 217093                      | Name tapes Ortiz & Bowers            |           | 3/31/2026 | DFT0006298     | 3/31/2026                         | 62.00       | 0.00     | 0.00 | 0.00     | 62.00    | 62.00    |
| Name tapes Ortiz & Bow      | 2.00                                 | 31.00     | 62.00     | 001-021-70060  | Uniforms                          |             | 62.00    |      |          |          |          |
| 22543738093589243364        | Mail Box                             |           | 3/31/2026 | DFT0006354     | 3/31/2026                         | 37.84       | 0.00     | 0.00 | 0.00     | 37.84    | 37.84    |
| Mail Box                    | 1.00                                 | 37.84     | 37.84     | 001-033-70230  | Equipment Repair & Maintenance    |             | 37.84    |      |          |          |          |
| 2274                        | deposit for sheering service         |           | 3/31/2026 | DFT0006475     | 3/31/2026                         | 180.00      | 0.00     | 0.00 | 0.00     | 180.00   | 180.00   |
| deposit for sheering ser    | 0.00                                 | 0.00      | 180.00    | 001-042-60000  | Other Professional Services       |             | 180.00   |      |          |          |          |
| 23397                       | Project Content                      |           | 3/31/2026 | DFT0006405     | 3/31/2026                         | 50.00       | 0.00     | 0.00 | 0.00     | 50.00    | 50.00    |
| Project Content             | 0.00                                 | 0.00      | 50.00     | 001-046-60220  | Software Subscriptions            |             | 50.00    |      |          |          |          |
| 26151524                    | 16x16 return air grills              |           | 3/31/2026 | DFT0006342     | 3/31/2026                         | 239.09      | 0.00     | 0.00 | 0.00     | 239.09   | 239.09   |
| 16x16 Return Air Grills &   | 1.00                                 | 239.09    | 239.09    | 984-070-70100  | Other Small Tools & Equipment     |             | 239.09   |      |          |          |          |
| 26543391053088207050        | Honeywell Heater City Hall Office    |           | 3/31/2026 | DFT0006337     | 3/31/2026                         | 33.06       | 0.00     | 0.00 | 0.00     | 33.06    | 33.06    |
| Heater City Hall Office     | 1.00                                 | 33.06     | 33.06     | 979-070-70000  | Other Operational Supplies        |             | 33.06    |      |          |          |          |
| 27861                       | Hotel stay for training - J. Gregory |           | 3/31/2026 | DFT0006317     | 3/31/2026                         | 1,067.61    | 0.00     | 0.00 | 0.00     | 1,067.61 | 1,067.61 |
| Hotel stay for training - . | 0.00                                 | 0.00      | 1,067.61  | 008-020-60760  | Training                          |             | 1,067.61 |      |          |          |          |
| 28543158001584236374        | animal feed and misc items           |           | 3/31/2026 | DFT0006451     | 3/31/2026                         | 35.28       | 0.00     | 0.00 | 0.00     | 35.28    | 35.28    |

**Vendor History Report**

Posting Date Range 03/31/2026 - 03/31/2026

| Payable Number            | Description                          | Post Date | 1099      | Payment Number | Payment Date                     | Amount      | Shipping | Tax  | Discount | Net     | Payment |
|---------------------------|--------------------------------------|-----------|-----------|----------------|----------------------------------|-------------|----------|------|----------|---------|---------|
| Item Description          | Units                                | Price     | Amount    | Account Number | Account Name                     | Dist Amount |          |      |          |         |         |
| animal feed and misc ite  | 1.00                                 | 35.28     | 35.28     | 001-042-70083  | Animal Food                      |             | 18.42    |      |          |         |         |
|                           |                                      |           |           | 001-042-70100  | Other Small Tools & Equipment    |             | 16.86    |      |          |         |         |
| 300902042264790755        | Stephens building dishwasher         |           | 3/31/2026 | DFT0006482     | 3/31/2026                        | 605.48      | 0.00     | 0.00 | 0.00     | 605.48  | 605.48  |
| Stephens building dishw   | 1.00                                 | 605.48    | 605.48    | 001-042-70100  | Other Small Tools & Equipment    |             | 605.48   |      |          |         |         |
| 300902047262526690        | Jefferson Subdivision Outdoor Lights |           | 3/31/2026 | DFT0006335     | 3/31/2026                        | 802.71      | 0.00     | 0.00 | 0.00     | 802.71  | 802.71  |
| Jefferson Subdivision Ot  | 1.00                                 | 802.71    | 802.71    | 989-070-80400  | Special Projects                 |             | 802.71   |      |          |         |         |
| 300902050262687302        | concesion fridge                     |           | 3/31/2026 | DFT0006481     | 3/31/2026                        | 538.00      | 0.00     | 0.00 | 0.00     | 538.00  | 538.00  |
| concesion fridge          | 1.00                                 | 538.00    | 538.00    | 001-042-70100  | Other Small Tools & Equipment    |             | 538.00   |      |          |         |         |
| 3040668826                | Tires                                |           | 3/31/2026 | DFT0006260     | 3/31/2026                        | 730.08      | 0.00     | 0.00 | 0.00     | 730.08  | 730.08  |
| Tires                     | 1.00                                 | 730.08    | 730.08    | 001-043-60340  | Vehicle Repair & Maintenance     |             | 730.08   |      |          |         |         |
| 31764780                  | Uniforms                             |           | 3/31/2026 | DFT0006404     | 3/31/2026                        | 410.69      | 0.00     | 0.00 | 0.00     | 410.69  | 410.69  |
| ACO - Uniforms            | 1.00                                 | 410.69    | 410.69    | 001-029-70060  | Uniforms                         |             | 410.69   |      |          |         |         |
| 341342                    | Nuts and bolts                       |           | 3/31/2026 | DFT0006273     | 3/31/2026                        | 49.35       | 0.00     | 0.00 | 0.00     | 49.35   | 49.35   |
| Nuts and bolts            | 1.00                                 | 49.35     | 49.35     | 001-041-70220  | Grounds Repair & Maintenance Suj |             | 49.35    |      |          |         |         |
| 34330195621037849219€     | Misc supplies                        |           | 3/31/2026 | DFT0006406     | 3/31/2026                        | 315.57      | 0.00     | 0.00 | 0.00     | 315.57  | 315.57  |
| Walmart                   | 1.00                                 | 315.57    | 315.57    | 001-046-70020  | Janitorial Supplies              |             | 315.57   |      |          |         |         |
| 34931011250374475196      | Ice melt & supplies to organize lab  |           | 3/31/2026 | DFT0006348     | 3/31/2026                        | 55.69       | 0.00     | 0.00 | 0.00     | 55.69   | 55.69   |
| Ice melt & supplies to oi | 1.00                                 | 55.69     | 55.69     | 001-021-70220  | Grounds Repair & Maintenance Suj |             | 55.69    |      |          |         |         |
| 35122720                  | PT Door Repair                       |           | 3/31/2026 | DFT0006345     | 3/31/2026                        | 454.40      | 0.00     | 0.00 | 0.00     | 454.40  | 454.40  |
| PT Door Repair            | 0.00                                 | 0.00      | 454.40    | 979-070-60310  | Building Repair & Maintenance    |             | 454.40   |      |          |         |         |
| 36233171                  | WeKan                                |           | 3/31/2026 | DFT0005891     | 3/31/2026                        | 93.60       | 0.00     | 0.00 | 0.00     | 93.60   | 93.60   |
| WeKan                     | 0.00                                 | 0.00      | 93.60     | 001-011-60760  | Training                         |             | 93.60    |      |          |         |         |
| 36339                     | diets                                |           | 3/31/2026 | DFT0006461     | 3/31/2026                        | 99.94       | 0.00     | 0.00 | 0.00     | 99.94   | 99.94   |
| diets                     | 1.00                                 | 99.94     | 99.94     | 001-042-70083  | Animal Food                      |             | 99.94    |      |          |         |         |
| 3743673                   | Velcon Hydrokit                      |           | 3/31/2026 | DFT0006382     | 3/31/2026                        | 435.25      | 0.00     | 0.00 | 0.00     | 435.25  | 435.25  |
| Velcon Hydrokit           | 1.00                                 | 435.25    | 435.25    | 031-066-70100  | Other Small Tools & Equipment    |             | 435.25   |      |          |         |         |
| 384664                    | exhibit heaters                      |           | 3/31/2026 | DFT0006465     | 3/31/2026                        | 114.99      | 0.00     | 0.00 | 0.00     | 114.99  | 114.99  |
| exhibit heaters           | 1.00                                 | 114.99    | 114.99    | 001-042-70100  | Other Small Tools & Equipment    |             | 114.99   |      |          |         |         |
| 416817                    | Refund for FTO training - B.Kirk     |           | 3/31/2026 | DFT0006285     | 3/31/2026                        | -225.00     | 0.00     | 0.00 | 0.00     | -225.00 | -225.00 |
| Refund for FTO training   | 0.00                                 | 0.00      | -225.00   | 001-021-60760  | Training                         |             | -225.00  |      |          |         |         |
| 43235                     | Evidence Tape                        |           | 3/31/2026 | DFT0006309     | 3/31/2026                        | 176.90      | 22.39    | 0.00 | 0.00     | 199.29  | 199.29  |
| Evidence Tape             | 10.00                                | 17.69     | 199.29    | 001-021-70000  | Other Operational Supplies       |             | 199.29   |      |          |         |         |
| 43490                     | Evidence Storage                     |           | 3/31/2026 | DFT0006313     | 3/31/2026                        | 306.47      | 0.00     | 0.00 | 0.00     | 306.47  | 306.47  |
| Evidence Storage          | 1.00                                 | 306.47    | 306.47    | 001-021-70000  | Other Operational Supplies       |             | 306.47   |      |          |         |         |
| 43535                     | Evidence Tape                        |           | 3/31/2026 | DFT0006311     | 3/31/2026                        | 265.35      | 22.91    | 0.00 | 0.00     | 288.26  | 288.26  |
| Evidence Tape             | 15.00                                | 17.69     | 288.26    | 001-021-70000  | Other Operational Supplies       |             | 288.26   |      |          |         |         |
| 43977771595821380791      | diets                                |           | 3/31/2026 | DFT0006445     | 3/31/2026                        | 11.38       | 0.00     | 0.00 | 0.00     | 11.38   | 11.38   |

**Vendor History Report**

Posting Date Range 03/31/2026 - 03/31/2026

| Payable Number          | Description               | Post Date | 1099      | Payment Number | Payment Date                      | Amount      | Shipping | Tax  | Discount | Net    | Payment |
|-------------------------|---------------------------|-----------|-----------|----------------|-----------------------------------|-------------|----------|------|----------|--------|---------|
| Item Description        | Units                     | Price     | Amount    | Account Number | Account Name                      | Dist Amount |          |      |          |        |         |
| diets                   | 1.00                      | 11.38     | 11.38     | 001-042-70083  | Animal Food                       | 11.38       |          |      |          |        |         |
| 43fab980946f220bbbf9c7  | City Hall - Hulu          |           | 3/31/2026 | DFT0006412     | 3/31/2026                         | 109.48      | 0.00     | 0.00 | 0.00     | 109.48 | 109.48  |
| City Hall Hulu          | 0.00                      | 0.00      | 109.48    | 001-004-60000  | Other Professional Services       | 109.48      |          |      |          |        |         |
| 4725970                 | KHRC LIHTC 3 Day Training |           | 3/31/2026 | DFT0006343     | 3/31/2026                         | 246.70      | 0.00     | 0.00 | 0.00     | 246.70 | 246.70  |
| KHRC LIHTC 3 Day Train  | 0.00                      | 0.00      | 246.70    | 979-070-60000  | Other Professional Services       | 246.70      |          |      |          |        |         |
| 5097526544              | diets and animal care     |           | 3/31/2026 | DFT0006460     | 3/31/2026                         | 68.27       | 0.00     | 0.00 | 0.00     | 68.27  | 68.27   |
| diets and animal care   | 1.00                      | 68.27     | 68.27     | 001-042-70000  | Other Operational Supplies        | 30.28       |          |      |          |        |         |
|                         |                           |           |           | 001-042-70083  | Animal Food                       | 37.99       |          |      |          |        |         |
| 51090                   | Faraday Bags              |           | 3/31/2026 | DFT0006310     | 3/31/2026                         | 259.99      | 9.99     | 0.00 | 0.00     | 269.98 | 269.98  |
| Faraday Bags            | 1.00                      | 259.99    | 269.98    | 001-021-70000  | Other Operational Supplies        | 269.98      |          |      |          |        |         |
| 5262128293094           | conference travel         |           | 3/31/2026 | DFT0006284     | 3/31/2026                         | 380.80      | 0.00     | 0.00 | 0.00     | 380.80 | 380.80  |
| conference travel       | 1.00                      | 380.80    | 380.80    | 001-041-60760  | Training                          | 380.80      |          |      |          |        |         |
| 5480871345              | Google Workspace          |           | 3/31/2026 | DFT0006398     | 3/31/2026                         | 290.40      | 0.00     | 0.00 | 0.00     | 290.40 | 290.40  |
| Google Fees             | 0.00                      | 0.00      | 145.20    | 001-001-60220  | Software Subscriptions            | 145.20      |          |      |          |        |         |
| Google Fees             | 0.00                      | 0.00      | 145.20    | 990-070-60000  | Other Professional Services       | 145.20      |          |      |          |        |         |
| 557148                  | PVC                       |           | 3/31/2026 | DFT0006267     | 3/31/2026                         | 13.47       | 0.00     | 0.00 | 0.00     | 13.47  | 13.47   |
| PVC                     | 1.00                      | 13.47     | 13.47     | 001-042-70210  | Building Repair & Maintenance Sup | 13.47       |          |      |          |        |         |
| 592178                  | diets                     |           | 3/31/2026 | DFT0006454     | 3/31/2026                         | 45.99       | 0.00     | 0.00 | 0.00     | 45.99  | 45.99   |
| diets                   | 1.00                      | 45.99     | 45.99     | 001-042-70083  | Animal Food                       | 45.99       |          |      |          |        |         |
| 6026112/1               | Taillight repair          |           | 3/31/2026 | DFT0006480     | 3/31/2026                         | 419.74      | 0.00     | 0.00 | 0.00     | 419.74 | 419.74  |
| Taillight repair        | 1.00                      | 419.74    | 419.74    | 001-043-60340  | Vehicle Repair & Maintenance      | 419.74      |          |      |          |        |         |
| 621248                  | diets                     |           | 3/31/2026 | DFT0006474     | 3/31/2026                         | 178.84      | 0.00     | 0.00 | 0.00     | 178.84 | 178.84  |
| diets                   | 1.00                      | 178.84    | 178.84    | 001-042-70083  | Animal Food                       | 178.84      |          |      |          |        |         |
| 67969788373743139930    | refrigerant               |           | 3/31/2026 | DFT0006347     | 3/31/2026                         | 20.00       | 0.00     | 0.00 | 0.00     | 20.00  | 20.00   |
| refrigerant             | 1.00                      | 20.00     | 20.00     | 001-021-60340  | Vehicle Repair & Maintenance      | 20.00       |          |      |          |        |         |
| 692451                  | diets                     |           | 3/31/2026 | DFT0006478     | 3/31/2026                         | 252.65      | 0.00     | 0.00 | 0.00     | 252.65 | 252.65  |
| diets                   | 1.00                      | 252.65    | 252.65    | 001-042-70083  | Animal Food                       | 252.65      |          |      |          |        |         |
| 698189                  | building drain            |           | 3/31/2026 | DFT0006274     | 3/31/2026                         | 49.47       | 0.00     | 0.00 | 0.00     | 49.47  | 49.47   |
| building drain          | 1.00                      | 49.47     | 49.47     | 001-042-70210  | Building Repair & Maintenance Sup | 49.47       |          |      |          |        |         |
| 73365887270017          | car rental insurance      |           | 3/31/2026 | DFT0006276     | 3/31/2026                         | 88.00       | 0.00     | 0.00 | 0.00     | 88.00  | 88.00   |
| car rental insurance    | 0.00                      | 0.00      | 88.00     | 001-041-60760  | Training                          | 88.00       |          |      |          |        |         |
| 758253                  | Tire patch                |           | 3/31/2026 | DFT0006269     | 3/31/2026                         | 20.00       | 0.00     | 0.00 | 0.00     | 20.00  | 20.00   |
| Tire patch              | 0.00                      | 0.00      | 20.00     | 001-041-60340  | Vehicle Repair & Maintenance      | 20.00       |          |      |          |        |         |
| 76688849988603526833    | diets, grounds and misc   |           | 3/31/2026 | DFT0006466     | 3/31/2026                         | 128.58      | 0.00     | 0.00 | 0.00     | 128.58 | 128.58  |
| diets, grounds and misc | 1.00                      | 128.58    | 128.58    | 001-042-70000  | Other Operational Supplies        | 75.44       |          |      |          |        |         |
|                         |                           |           |           | 001-042-70083  | Animal Food                       | 13.38       |          |      |          |        |         |
|                         |                           |           |           | 001-042-70220  | Grounds Repair & Maintenance Suj  | 39.76       |          |      |          |        |         |

**Vendor History Report**

Posting Date Range 03/31/2026 - 03/31/2026

| Payable Number        | Description                    | Post Date | 1099   | Payment Number | Payment Date                     | Amount      | Shipping | Tax  | Discount | Net    | Payment |
|-----------------------|--------------------------------|-----------|--------|----------------|----------------------------------|-------------|----------|------|----------|--------|---------|
| Item Description      | Units                          | Price     | Amount | Account Number | Account Name                     | Dist Amount |          |      |          |        |         |
| 775868984967607506863 | Lab gear                       | 3/31/2026 |        | DFT0006350     | 3/31/2026                        | 133.61      | 0.00     | 0.00 | 0.00     | 133.61 | 133.61  |
|                       | Lab gear                       | 1.00      | 133.61 | 001-021-70010  | Office Supplies                  | 133.61      |          |      |          |        |         |
| 79088427967603530873  | diets and misc office supplies | 3/31/2026 |        | DFT0006458     | 3/31/2026                        | 61.88       | 0.00     | 0.00 | 0.00     | 61.88  | 61.88   |
|                       | diets and office supplies      | 1.00      | 61.88  | 001-041-70000  | Other Operational Supplies       | 4.94        |          |      |          |        |         |
|                       |                                |           |        | 001-042-70000  | Other Operational Supplies       | 4.94        |          |      |          |        |         |
|                       |                                |           |        | 001-042-70083  | Animal Food                      | 52.00       |          |      |          |        |         |
| 805103                | Badges                         | 3/31/2026 |        | DFT0006316     | 3/31/2026                        | 896.00      | 9.95     | 0.00 | 0.00     | 905.95 | 905.95  |
|                       | Badges                         | 5.00      | 179.20 | 001-021-70060  | Uniforms                         | 905.95      |          |      |          |        |         |
| 844697                | Postage                        | 3/31/2026 |        | DFT0005890     | 3/31/2026                        | 18.90       | 0.00     | 0.00 | 0.00     | 18.90  | 18.90   |
|                       | Postage                        | 0.00      | 0.00   | 033-063-60720  | Printing & Mailing               | 18.90       |          |      |          |        |         |
| 878488                | Broom attachment               | 3/31/2026 |        | DFT0006283     | 3/31/2026                        | 307.48      | 0.00     | 0.00 | 0.00     | 307.48 | 307.48  |
|                       | Broom attachment               | 1.00      | 307.48 | 001-041-70100  | Other Small Tools & Equipment    | 307.48      |          |      |          |        |         |
| 880946009767416908675 | diets and office supplies      | 3/31/2026 |        | DFT0006467     | 3/31/2026                        | 130.52      | 0.00     | 0.00 | 0.00     | 130.52 | 130.52  |
|                       | diets and office supplies      | 1.00      | 130.52 | 001-042-70000  | Other Operational Supplies       | 67.17       |          |      |          |        |         |
|                       |                                |           |        | 001-042-70083  | Animal Food                      | 63.35       |          |      |          |        |         |
| 886976822726412947645 | diets and supplies             | 3/31/2026 |        | DFT0006462     | 3/31/2026                        | 103.34      | 0.00     | 0.00 | 0.00     | 103.34 | 103.34  |
|                       | diets and supplies             | 1.00      | 103.34 | 001-042-70000  | Other Operational Supplies       | 44.18       |          |      |          |        |         |
|                       |                                |           |        | 001-042-70083  | Animal Food                      | 59.16       |          |      |          |        |         |
| 97118648              | Grammerly                      | 3/31/2026 |        | DFT0006413     | 3/31/2026                        | 139.95      | 0.00     | 0.00 | 0.00     | 139.95 | 139.95  |
|                       | Grammerly                      | 0.00      | 0.00   | 001-001-60220  | Software Subscriptions           | 139.95      |          |      |          |        |         |
| 999B77AF-0007         | Open AI                        | 3/31/2026 |        | DFT0006397     | 3/31/2026                        | 200.38      | 0.00     | 0.00 | 0.00     | 200.38 | 200.38  |
|                       | Open AI - Admin                | 0.00      | 0.00   | 001-001-60220  | Software Subscriptions           | 72.83       |          |      |          |        |         |
|                       | Open AI - Police               | 0.00      | 0.00   | 001-021-60220  | Software Subscriptions           | 54.63       |          |      |          |        |         |
|                       | Open AI                        | 0.00      | 0.00   | 001-011-60220  | Software Subscriptions           | 18.23       |          |      |          |        |         |
|                       | PU Open AI                     | 0.00      | 0.00   | 033-063-60220  | Software Subscriptions           | 18.23       |          |      |          |        |         |
|                       | Open AI                        | 0.00      | 0.00   | 001-041-60220  | Software Subscriptions           | 18.23       |          |      |          |        |         |
|                       | Open AI                        | 0.00      | 0.00   | 001-026-60220  | Software Subscriptions           | 18.23       |          |      |          |        |         |
| A81846/P              | Tubing, Clamps, Misc Tools     | 3/31/2026 |        | DFT0006388     | 3/31/2026                        | 112.09      | 0.00     | 0.00 | 0.00     | 112.09 | 112.09  |
|                       | Tubing, Clamps, Misc Tc        | 1.00      | 112.09 | 033-064-70100  | Other Small Tools & Equipment    | 112.09      |          |      |          |        |         |
| A82914/P              | exhibit supplies               | 3/31/2026 |        | DFT0006455     | 3/31/2026                        | 47.94       | 0.00     | 0.00 | 0.00     | 47.94  | 47.94   |
|                       | exhibit supplies               | 1.00      | 47.94  | 001-042-70220  | Grounds Repair & Maintenance Suj | 47.94       |          |      |          |        |         |
| B25733                | Turbo rim blade                | 3/31/2026 |        | DFT0006266     | 3/31/2026                        | 12.49       | 0.00     | 0.00 | 0.00     | 12.49  | 12.49   |
|                       | Turbo rim blade                | 1.00      | 12.49  | 001-042-70100  | Other Small Tools & Equipment    | 12.49       |          |      |          |        |         |
| B25816                | Chisel                         | 3/31/2026 |        | DFT0006268     | 3/31/2026                        | 14.49       | 0.00     | 0.00 | 0.00     | 14.49  | 14.49   |
|                       | Chisel                         | 1.00      | 14.49  | 001-042-70100  | Other Small Tools & Equipment    | 14.49       |          |      |          |        |         |
| B26154                | grinder wheel rental           | 3/31/2026 |        | DFT0006271     | 3/31/2026                        | 32.00       | 0.00     | 0.00 | 0.00     | 32.00  | 32.00   |
|                       | grinder wheel rental           | 1.00      | 32.00  | 001-042-60310  | Building Repair & Maintenance    | 32.00       |          |      |          |        |         |
| B28086                | Remesh mat                     | 3/31/2026 |        | DFT0006279     | 3/31/2026                        | 117.00      | 0.00     | 0.00 | 0.00     | 117.00 | 117.00  |

**Vendor History Report**

Posting Date Range 03/31/2026 - 03/31/2026

| Payable Number   | Description                                   | Post Date | 1099      | Payment Number | Payment Date  | Amount                            | Shipping | Tax  | Discount | Net  | Payment  |
|------------------|---|-----------|-----------|----------------|---------------|-----------------------------------|----------|------|----------|------|----------|
| Item Description | Units   | Price     | Amount    | Account Number | Account Name  | Dist Amount                       |          |      |          |      |          |
|                  | Remesh mat                                    | 1.00      | 117.00    | 117.00         | 001-042-70210 | Building Repair & Maintenance Sup | 117.00   |      |          |      |          |
| B28397           | exhibit maint                                 |           | 3/31/2026 |                | DFT0006442    | 3/31/2026                         | 5.38     | 0.00 | 0.00     | 0.00 | 5.38     |
|                  | exhibit maint                                 | 1.00      | 5.38      | 5.38           | 001-042-70220 | Grounds Repair & Maintenance Suj  | 5.38     |      |          |      |          |
| B30208           | Tension bar                                   |           | 3/31/2026 |                | DFT0006263    | 3/31/2026                         | 7.58     | 0.00 | 0.00     | 0.00 | 7.58     |
|                  | Tension bar                                   | 1.00      | 7.58      | 7.58           | 001-041-70220 | Grounds Repair & Maintenance Suj  | 7.58     |      |          |      |          |
| B31923           | Concrete mix & pallet                         |           | 3/31/2026 |                | DFT0006282    | 3/31/2026                         | 251.38   | 0.00 | 0.00     | 0.00 | 251.38   |
|                  | Concrete mix & pallet                         | 1.00      | 251.38    | 251.38         | 001-041-70220 | Grounds Repair & Maintenance Suj  | 251.38   |      |          |      |          |
| BW9AL2           | Flight  |           | 3/31/2026 |                | DFT0006488    | 3/31/2026                         | 215.20   | 0.00 | 0.00     | 0.00 | 215.20   |
|                  | training flight                               | 0.00      | 0.00      | 215.20         | 001-027-60760 | Training                          | 215.20   |      |          |      |          |
| CM0000095        | Return of 1 of 2 Pairs of EMS Pants for B. Li |           | 3/31/2026 |                | DFT0006355    | 3/31/2026                         | -74.25   | 0.00 | 0.00     | 0.00 | -74.25   |
|                  | Return of 1 of 2 Pairs of                     | -1.00     | 74.25     | -74.25         | 001-026-70060 | Uniforms                          | -74.25   |      |          |      |          |
| CM0000096        | Refund for Brittney Landell Job Shirt         |           | 3/31/2026 |                | DFT0006356    | 3/31/2026                         | -69.99   | 0.00 | 0.00     | 0.00 | -69.99   |
|                  | Refund for Brittney Lanc                      | -1.00     | 69.99     | -69.99         | 001-026-70060 | Uniforms                          | -69.99   |      |          |      |          |
| D558596          | Repair and replacement of Fire Extinguisher   |           | 3/31/2026 |                | DFT0006363    | 3/31/2026                         | 524.30   | 0.00 | 0.00     | 0.00 | 524.30   |
|                  | Repair and replacement                        | 1.00      | 524.30    | 524.30         | 001-026-60330 | Equipment Repair & Maintenance    | 524.30   |      |          |      |          |
| E0200YC1VF       | Email Account                                 |           | 3/31/2026 |                | DFT0006401    | 3/31/2026                         | 36.00    | 0.00 | 0.00     | 0.00 | 36.00    |
|                  | Email Account                                 | 0.00      | 0.00      | 36.00          | 001-009-60220 | Software Subscriptions            | 36.00    |      |          |      |          |
| E0200YCM5N       | Email   |           | 3/31/2026 |                | DFT0006400    | 3/31/2026                         | 8.00     | 0.00 | 0.00     | 0.00 | 8.00     |
|                  | Email Account                                 | 0.00      | 0.00      | 8.00           | 001-009-60220 | Software Subscriptions            | 8.00     |      |          |      |          |
| INV0005083       | Adobe   |           | 3/31/2026 |                | DFT0006399    | 3/31/2026                         | 1,119.64 | 0.00 | 0.00     | 0.00 | 1,119.64 |
|                  | Adobe - admin                                 | 0.00      | 0.00      | 290.00         | 001-001-60220 | Software Subscriptions            | 290.00   |      |          |      |          |
|                  | Finance                                       | 0.00      | 0.00      | 242.81         | 001-011-60220 | Software Subscriptions            | 242.81   |      |          |      |          |
|                  | Housing                                       | 0.00      | 0.00      | 170.00         | 990-070-60000 | Other Professional Services       | 170.00   |      |          |      |          |
|                  | Police  | 0.00      | 0.00      | 124.94         | 001-021-60220 | Software Subscriptions            | 124.94   |      |          |      |          |
|                  | Tax   | 0.00      | 0.00      | 94.98          | 001-009-60220 | Software Subscriptions            | 94.98    |      |          |      |          |
|                  | Public Utility                                | 0.00      | 0.00      | 71.97          | 033-063-60220 | Software Subscriptions            | 71.97    |      |          |      |          |
|                  | Park  | 0.00      | 0.00      | 52.97          | 001-041-60220 | Software Subscriptions            | 52.97    |      |          |      |          |
|                  | Code Enf & Bldg                               | 0.00      | 0.00      | 47.98          | 001-027-60000 | Other Professional Services       | 47.98    |      |          |      |          |
|                  | Fire-EMS                                      | 0.00      | 0.00      | 23.99          | 001-026-60220 | Software Subscriptions            | 23.99    |      |          |      |          |
| INV0005088       | KACE Conference                               |           | 3/31/2026 |                | DFT0006403    | 3/31/2026                         | 250.00   | 0.00 | 0.00     | 0.00 | 250.00   |
|                  | KACE Conference                               | 0.00      | 0.00      | 250.00         | 001-027-60760 | Training                          | 250.00   |      |          |      |          |
| INV0005106       | Business prime membership                     |           | 3/31/2026 |                | DFT0005892    | 3/31/2026                         | 349.00   | 0.00 | 0.00     | 0.00 | 349.00   |
|                  | Business prime member                         | 0.00      | 0.00      | 349.00         | 001-009-60270 | Membership Dues                   | 349.00   |      |          |      |          |
| INV0005151       | Flight Software                               |           | 3/31/2026 |                | DFT0006380    | 3/31/2026                         | 284.70   | 0.00 | 0.00     | 0.00 | 284.70   |
|                  | Flight Software                               | 0.00      | 0.00      | 284.70         | 031-066-60220 | Software Subscriptions            | 284.70   |      |          |      |          |
| INV0005308       | Return of 2 of 2 Pairs of EMS Pants for B. Li |           | 3/31/2026 |                | DFT0006365    | 3/31/2026                         | -74.25   | 0.00 | 0.00     | 0.00 | -74.25   |
|                  | Return of 2 of 2 Pairs of                     | -1.00     | 74.25     | -74.25         | 001-026-70060 | Uniforms                          | -74.25   |      |          |      |          |
| INV0005330       | KHRC Training Parking Garage Fee              |           | 3/31/2026 |                | DFT0006336    | 3/31/2026                         | 12.00    | 0.00 | 0.00     | 0.00 | 12.00    |

**Vendor History Report**

Posting Date Range 03/31/2026 - 03/31/2026

| Payable Number            | Description                          | Post Date | 1099      | Payment Number | Payment Date                | Amount                                  | Shipping         | Tax          | Discount    | Net         | Payment          |                  |
|---------------------------|--------------------------------------|-----------|-----------|----------------|-----------------------------|---|------------------|--------------|-------------|-------------|------------------|------------------|
| Item Description          | Units                                | Price     | Amount    | Account Number | Account Name                | Dist Amount                             |                  |              |             |             |                  |                  |
| KHRC LIHTC Training Pai   | 0.00                                 | 0.00      | 12.00     | 979-070-60000  | Other Professional Services | 12.00                                   |                  |              |             |             |                  |                  |
| INV0005332                | Canva Annual Subscription            |           | 3/31/2026 | DFT0006339     | 3/31/2026                   | 200.00                                  | 0.00             | 0.00         | 0.00        | 200.00      | 200.00           |                  |
| Canva Annual Subscripti   | 0.00                                 | 0.00      | 200.00    | 979-070-60000  | Other Professional Services | 200.00                                  |                  |              |             |             |                  |                  |
| INV0005349                | UBER during training - J. Gregory    |           | 3/31/2026 | DFT0006296     | 3/31/2026                   | 47.92                                   | 0.00             | 0.00         | 0.00        | 47.92       | 47.92            |                  |
| UBER during training - J. | 0.00                                 | 0.00      | 47.92     | 008-020-60760  | Training                    | 47.92                                   |                  |              |             |             |                  |                  |
| INV0005350                | UBER for training - J. Gregory       |           | 3/31/2026 | DFT0006300     | 3/31/2026                   | 75.39                                   | 0.00             | 0.00         | 0.00        | 75.39       | 75.39            |                  |
| UBER for training - J. Gr | 0.00                                 | 0.00      | 75.39     | 008-020-60760  | Training                    | 75.39                                   |                  |              |             |             |                  |                  |
| INV0005368                | AAKC Spring Conferenece - P. Hayes   |           | 3/31/2026 | DFT0006305     | 3/31/2026                   | 150.00                                  | 0.00             | 0.00         | 0.00        | 150.00      | 150.00           |                  |
| AAKC Spring Conferener    | 0.00                                 | 0.00      | 150.00    | 001-021-60760  | Training                    | 150.00                                  |                  |              |             |             |                  |                  |
| INV0005439                | Dish TV                              |           | 3/31/2026 | DFT0006384     | 3/31/2026                   | 139.12                                  | 0.00             | 0.00         | 0.00        | 139.12      | 139.12           |                  |
| Dish TV                   | 0.00                                 | 0.00      | 139.12    | 031-066-60550  | Television                  | 139.12                                  |                  |              |             |             |                  |                  |
| INV22435                  | Cocaine Detection kit                |           | 3/31/2026 | DFT0006301     | 3/31/2026                   | 124.50                                  | 0.00             | 0.00         | 0.00        | 124.50      | 124.50           |                  |
| Cocaine Detection kit     | 5.00                                 | 24.90     | 124.50    | 001-021-70000  | Other Operational Supplies  | 124.50                                  |                  |              |             |             |                  |                  |
| MCO-992192                | Motel & Rental Car for Conference    |           | 3/31/2026 | DFT0006490     | 3/31/2026                   | 584.99                                  | 0.00             | 0.00         | 0.00        | 584.99      | 584.99           |                  |
| Motel & Rental Car for C  | 0.00                                 | 0.00      | 584.99    | 001-027-60760  | Training                    | 584.99                                  |                  |              |             |             |                  |                  |
| OBNN3Q                    | Training flight                      |           | 3/31/2026 | DFT0006489     | 3/31/2026                   | 300.20                                  | 0.00             | 0.00         | 0.00        | 300.20      | 300.20           |                  |
| Training - flight         | 0.00                                 | 0.00      | 300.20    | 001-027-60760  | Training                    | 300.20                                  |                  |              |             |             |                  |                  |
| PPTXN-261413769           | Translation Services                 |           | 3/31/2026 | DFT0006302     | 3/31/2026                   | 130.35                                  | 0.00             | 0.00         | 0.00        | 130.35      | 130.35           |                  |
| Translation Services      | 0.00                                 | 0.00      | 130.35    | 001-021-60000  | Other Professional Services | 130.35                                  |                  |              |             |             |                  |                  |
| PPTXN-261425435           | Translation services                 |           | 3/31/2026 | DFT0006290     | 3/31/2026                   | 19.75                                   | 0.00             | 0.00         | 0.00        | 19.75       | 19.75            |                  |
| Translation services      | 0.00                                 | 0.00      | 19.75     | 001-021-60000  | Other Professional Services | 19.75                                   |                  |              |             |             |                  |                  |
| PPTXN-261425437           | Translation services                 |           | 3/31/2026 | DFT0006289     | 3/31/2026                   | 15.80                                   | 0.00             | 0.00         | 0.00        | 15.80       | 15.80            |                  |
| Translation services      | 0.00                                 | 0.00      | 15.80     | 001-021-60000  | Other Professional Services | 15.80                                   |                  |              |             |             |                  |                  |
| S059586                   | POS Software                         |           | 3/31/2026 | DFT0006375     | 3/31/2026                   | 30.00                                   | 0.00             | 0.00         | 0.00        | 30.00       | 30.00            |                  |
| POS Software              | 0.00                                 | 0.00      | 30.00     | 031-066-60220  | Software Subscriptions      | 30.00                                   |                  |              |             |             |                  |                  |
| WEB269439                 | Adult Disposable Ventilator Circuits |           | 3/31/2026 | DFT0006361     | 3/31/2026                   | 230.23                                  | 0.00             | 0.00         | 0.00        | 230.23      | 230.23           |                  |
| Adult Disposable Ventile  | 1.00                                 | 230.23    | 230.23    | 001-026-70081  | Medical Supplies            | 230.23                                  |                  |              |             |             |                  |                  |
| <b>Vendors: (1)</b>       |                                      |           |           |                |                             | <b>Total 01 - City of Independence:</b> | <b>38,064.89</b> | <b>72.72</b> | <b>0.00</b> | <b>0.00</b> | <b>38,137.61</b> | <b>38,137.61</b> |
| <b>Vendors: (1)</b>       |                                      |           |           |                |                             | <b>Report Total:</b>                    | <b>38,064.89</b> | <b>72.72</b> | <b>0.00</b> | <b>0.00</b> | <b>38,137.61</b> | <b>38,137.61</b> |



# Payment Register

Bank: General - Community National Bank

|   |   |                                   |                               |                                |                                    |   |
|---|---|-----------------------------------|-------------------------------|--------------------------------|------------------------------------|---|
| <b>Vendor Number</b><br><a href="#">035889</a>            | <b>Vendor Name</b><br>AT&T                          |                                   |                               |                                |                                    | <b>Total Vendor Amount</b><br>10,471.71 |
| <b>Payment Type</b><br>Bank Draft                         | <b>Payment Number</b><br><a href="#">DFT0006432</a> |                                   |                               |                                | <b>Payment Date</b><br>03/31/2026  | <b>Payment Amount</b><br>10,471.71      |
| <b>Payable Number</b><br><a href="#">March 2026 Draft</a> | <b>Description</b><br>Monthly Draft                 | <b>Payable Date</b><br>03/31/2026 | <b>Due Date</b><br>04/30/2026 | <b>Discount Amount</b><br>0.00 | <b>Payable Amount</b><br>10,471.71 |   |

|   |   |                                   |                               |                                |                                   |  |
|---|---|-----------------------------------|-------------------------------|--------------------------------|-----------------------------------|--|
| <b>Vendor Number</b><br><a href="#">036623</a>            | <b>Vendor Name</b><br>AT&T                          |                                   |                               |                                |                                   | <b>Total Vendor Amount</b><br>3,245.93 |
| <b>Payment Type</b><br>Bank Draft                         | <b>Payment Number</b><br><a href="#">DFT0006433</a> |                                   |                               |                                | <b>Payment Date</b><br>03/31/2026 | <b>Payment Amount</b><br>3,245.93      |
| <b>Payable Number</b><br><a href="#">March 2026 Draft</a> | <b>Description</b><br>AT & T Internet               | <b>Payable Date</b><br>03/31/2026 | <b>Due Date</b><br>04/30/2026 | <b>Discount Amount</b><br>0.00 | <b>Payable Amount</b><br>3,245.93 |  |

|   |   |                                   |                               |                                |                                   |  |
|---|---|-----------------------------------|-------------------------------|--------------------------------|-----------------------------------|--|
| <b>Vendor Number</b><br><a href="#">034736</a>            | <b>Vendor Name</b><br>AT&T Mobility                 |                                   |                               |                                |                                   | <b>Total Vendor Amount</b><br>3,231.70 |
| <b>Payment Type</b><br>Bank Draft                         | <b>Payment Number</b><br><a href="#">DFT0006486</a> |                                   |                               |                                | <b>Payment Date</b><br>03/31/2026 | <b>Payment Amount</b><br>3,231.70      |
| <b>Payable Number</b><br><a href="#">March 2026 Draft</a> | <b>Description</b><br>Monthly First Net Telephone   | <b>Payable Date</b><br>03/31/2026 | <b>Due Date</b><br>04/30/2026 | <b>Discount Amount</b><br>0.00 | <b>Payable Amount</b><br>3,231.70 |  |

|   |   |                                   |                               |                                |                                    |   |
|---|---|-----------------------------------|-------------------------------|--------------------------------|------------------------------------|---|
| <b>Vendor Number</b><br><a href="#">033052</a>            | <b>Vendor Name</b><br>Atmos Energy                  |                                   |                               |                                |                                    | <b>Total Vendor Amount</b><br>18,566.40 |
| <b>Payment Type</b><br>Bank Draft                         | <b>Payment Number</b><br><a href="#">DFT0006419</a> |                                   |                               |                                | <b>Payment Date</b><br>03/31/2026  | <b>Payment Amount</b><br>18,566.40      |
| <b>Payable Number</b><br><a href="#">March 2026 Draft</a> | <b>Description</b><br>Atmos Monthly Draft           | <b>Payable Date</b><br>03/31/2026 | <b>Due Date</b><br>04/30/2026 | <b>Discount Amount</b><br>0.00 | <b>Payable Amount</b><br>18,566.40 |   |

|   |   |                                   |                               |                                |                                     |  |
|---|---|-----------------------------------|-------------------------------|--------------------------------|-------------------------------------|--|
| <b>Vendor Number</b><br><a href="#">003431</a>            | <b>Vendor Name</b><br>Blue Cross/Blue Shield Of     |                                   |                               |                                |                                     | <b>Total Vendor Amount</b><br>118,318.19 |
| <b>Payment Type</b><br>Bank Draft                         | <b>Payment Number</b><br><a href="#">DFT0006330</a> |                                   |                               |                                | <b>Payment Date</b><br>03/31/2026   | <b>Payment Amount</b><br>2,964.20        |
| <b>Payable Number</b><br><a href="#">023322106 Dental</a> | <b>Description</b><br>Dental Insurance Premium      | <b>Payable Date</b><br>03/31/2026 | <b>Due Date</b><br>04/30/2026 | <b>Discount Amount</b><br>0.00 | <b>Payable Amount</b><br>2,964.20   |  |
| <b>Payment Type</b><br>Bank Draft                         | <b>Payment Number</b><br><a href="#">DFT0006331</a> |                                   |                               |                                | <b>Payment Date</b><br>03/31/2026   | <b>Payment Amount</b><br>115,353.99      |
| <b>Payable Number</b><br><a href="#">023322106 Health</a> | <b>Description</b><br>Health Insurance Premium      | <b>Payable Date</b><br>03/31/2026 | <b>Due Date</b><br>04/30/2026 | <b>Discount Amount</b><br>0.00 | <b>Payable Amount</b><br>115,353.99 |  |

|   |  |                                   |                               |                                |                                   |                                     |
|---|--|-----------------------------------|-------------------------------|--------------------------------|-----------------------------------|-------------------------------------|
| <b>Vendor Number</b><br><a href="#">035464</a>            | <b>Vendor Name</b><br>Conoco-Phillips Fleet Services |                                   |                               |                                |                                   | <b>Total Vendor Amount</b><br>63.88 |
| <b>Payment Type</b><br>Bank Draft                         | <b>Payment Number</b><br><a href="#">DFT0006434</a>  |                                   |                               |                                | <b>Payment Date</b><br>03/31/2026 | <b>Payment Amount</b><br>63.88      |
| <b>Payable Number</b><br><a href="#">March 2026 Draft</a> | <b>Description</b><br>Fleet Monthly Charge           | <b>Payable Date</b><br>03/31/2026 | <b>Due Date</b><br>04/30/2026 | <b>Discount Amount</b><br>0.00 | <b>Payable Amount</b><br>63.88    |                                     |

|   |   |                                   |                               |                                |                                   |  |
|---|---|-----------------------------------|-------------------------------|--------------------------------|-----------------------------------|--|
| <b>Vendor Number</b><br><a href="#">037586</a>            | <b>Vendor Name</b><br>Directv                       |                                   |                               |                                |                                   | <b>Total Vendor Amount</b><br>1,140.20 |
| <b>Payment Type</b><br>Bank Draft                         | <b>Payment Number</b><br><a href="#">DFT0006424</a> |                                   |                               |                                | <b>Payment Date</b><br>03/31/2026 | <b>Payment Amount</b><br>1,140.20      |
| <b>Payable Number</b><br><a href="#">March 2026 Draft</a> | <b>Description</b><br>Monthly Directv Draft         | <b>Payable Date</b><br>03/31/2026 | <b>Due Date</b><br>04/30/2026 | <b>Discount Amount</b><br>0.00 | <b>Payable Amount</b><br>1,140.20 |  |

**Payment Register**

**APPKT01940 - March 2026 Draft**

| Vendor Number           | Vendor Name                          |                     |                 |                        |                       | Total Vendor Amount   |
|-------------------------|--------------------------------------|---------------------|-----------------|------------------------|-----------------------|-----------------------|
| <a href="#">037937</a>  | Employee Benefits Corporation        |                     |                 |                        |                       | 488.47                |
| <b>Payment Type</b>     | <b>Payment Number</b>                |                     |                 | <b>Payment Date</b>    |                       | <b>Payment Amount</b> |
| Bank Draft              | <a href="#">DFT0006435</a>           |                     |                 | 03/31/2026             |                       | 128.00                |
| <b>Payable Number</b>   | <b>Description</b>                   | <b>Payable Date</b> | <b>Due Date</b> | <b>Discount Amount</b> | <b>Payable Amount</b> |                       |
| <a href="#">5326965</a> | EBC Consolidated Fee Monthly Invoice | 03/15/2026          | 04/14/2026      | 0.00                   | 128.00                |                       |
| Bank Draft              | <a href="#">DFT0006436</a>           |                     |                 | 03/31/2026             |                       | 220.59                |
| <b>Payable Number</b>   | <b>Description</b>                   | <b>Payable Date</b> | <b>Due Date</b> | <b>Discount Amount</b> | <b>Payable Amount</b> |                       |
| <a href="#">5306908</a> | EBC Consolidated Claims Register     | 03/03/2026          | 04/02/2026      | 0.00                   | 220.59                |                       |
| Bank Draft              | <a href="#">DFT0006437</a>           |                     |                 | 03/31/2026             |                       | 25.00                 |
| <b>Payable Number</b>   | <b>Description</b>                   | <b>Payable Date</b> | <b>Due Date</b> | <b>Discount Amount</b> | <b>Payable Amount</b> |                       |
| <a href="#">5312189</a> | EBC Consolidated Claims Register     | 03/06/2026          | 04/05/2026      | 0.00                   | 25.00                 |                       |
| Bank Draft              | <a href="#">DFT0006438</a>           |                     |                 | 03/31/2026             |                       | 25.00                 |
| <b>Payable Number</b>   | <b>Description</b>                   | <b>Payable Date</b> | <b>Due Date</b> | <b>Discount Amount</b> | <b>Payable Amount</b> |                       |
| <a href="#">5335012</a> | EBC Consolidated Claims Register     | 03/17/2026          | 04/16/2026      | 0.00                   | 25.00                 |                       |
| Bank Draft              | <a href="#">DFT0006439</a>           |                     |                 | 03/31/2026             |                       | 25.00                 |
| <b>Payable Number</b>   | <b>Description</b>                   | <b>Payable Date</b> | <b>Due Date</b> | <b>Discount Amount</b> | <b>Payable Amount</b> |                       |
| <a href="#">5343597</a> | EBC Consolidated Claims Register     | 03/24/2026          | 04/23/2026      | 0.00                   | 25.00                 |                       |
| Bank Draft              | <a href="#">DFT0006440</a>           |                     |                 | 03/31/2026             |                       | 64.88                 |
| <b>Payable Number</b>   | <b>Description</b>                   | <b>Payable Date</b> | <b>Due Date</b> | <b>Discount Amount</b> | <b>Payable Amount</b> |                       |
| <a href="#">5346090</a> | EBC Consolidated Claims Register     | 03/25/2026          | 04/24/2026      | 0.00                   | 64.88                 |                       |

| Vendor Number                    | Vendor Name                |                     |                 |                        |                       | Total Vendor Amount   |
|----------------------------------|----------------------------|---------------------|-----------------|------------------------|-----------------------|-----------------------|
| <a href="#">032855</a>           | Everygy                    |                     |                 |                        |                       | 74,310.12             |
| <b>Payment Type</b>              | <b>Payment Number</b>      |                     |                 | <b>Payment Date</b>    |                       | <b>Payment Amount</b> |
| Bank Draft                       | <a href="#">DFT0006420</a> |                     |                 | 03/31/2026             |                       | 74,310.12             |
| <b>Payable Number</b>            | <b>Description</b>         | <b>Payable Date</b> | <b>Due Date</b> | <b>Discount Amount</b> | <b>Payable Amount</b> |                       |
| <a href="#">March 2026 Draft</a> | Everygy Monthly Draft      | 03/31/2026          | 04/30/2026      | 0.00                   | 74,310.12             |                       |

| Vendor Number                    | Vendor Name                |                     |                 |                        |                       | Total Vendor Amount   |
|----------------------------------|----------------------------|---------------------|-----------------|------------------------|-----------------------|-----------------------|
| <a href="#">038274</a>           | Gateway Infrastructure LLC |                     |                 |                        |                       | 760.00                |
| <b>Payment Type</b>              | <b>Payment Number</b>      |                     |                 | <b>Payment Date</b>    |                       | <b>Payment Amount</b> |
| Bank Draft                       | <a href="#">DFT0006423</a> |                     |                 | 03/31/2026             |                       | 760.00                |
| <b>Payable Number</b>            | <b>Description</b>         | <b>Payable Date</b> | <b>Due Date</b> | <b>Discount Amount</b> | <b>Payable Amount</b> |                       |
| <a href="#">March 2026 Draft</a> | Monthly Internet Charges   | 03/31/2026          | 03/31/2026      | 0.00                   | 760.00                |                       |

| Vendor Number                    | Vendor Name                |                     |                 |                        |                       | Total Vendor Amount   |
|----------------------------------|----------------------------|---------------------|-----------------|------------------------|-----------------------|-----------------------|
| <a href="#">037526</a>           | Global Payments Integrated |                     |                 |                        |                       | 34,607.91             |
| <b>Payment Type</b>              | <b>Payment Number</b>      |                     |                 | <b>Payment Date</b>    |                       | <b>Payment Amount</b> |
| Bank Draft                       | <a href="#">DFT0006422</a> |                     |                 | 03/31/2026             |                       | 34,607.91             |
| <b>Payable Number</b>            | <b>Description</b>         | <b>Payable Date</b> | <b>Due Date</b> | <b>Discount Amount</b> | <b>Payable Amount</b> |                       |
| <a href="#">March 2026 Draft</a> | Monthly Draft              | 03/31/2026          | 04/30/2026      | 0.00                   | 34,607.91             |                       |

| Vendor Number                    | Vendor Name   |                     |                 |                        |                       | Total Vendor Amount   |
|----------------------------------|---|---------------------|-----------------|------------------------|-----------------------|-----------------------|
| <a href="#">013110</a>           | Kansas Department Of Revenue - Department of Taxati |                     |                 |                        |                       | 4,485.67              |
| <b>Payment Type</b>              | <b>Payment Number</b>                               |                     |                 | <b>Payment Date</b>    |                       | <b>Payment Amount</b> |
| Bank Draft                       | <a href="#">DFT0006430</a>                          |                     |                 | 03/31/2026             |                       | 4,485.67              |
| <b>Payable Number</b>            | <b>Description</b>                                  | <b>Payable Date</b> | <b>Due Date</b> | <b>Discount Amount</b> | <b>Payable Amount</b> |                       |
| <a href="#">March 2026 Draft</a> | Water/Fuel Tax                                      | 03/31/2026          | 04/30/2026      | 0.00                   | 4,485.67              |                       |

| Vendor Number                    | Vendor Name                |                     |                 |                        |                       | Total Vendor Amount   |
|----------------------------------|----------------------------|---------------------|-----------------|------------------------|-----------------------|-----------------------|
| <a href="#">035708</a>           | Kansas State Treasurer     |                     |                 |                        |                       | 570,041.44            |
| <b>Payment Type</b>              | <b>Payment Number</b>      |                     |                 | <b>Payment Date</b>    |                       | <b>Payment Amount</b> |
| Bank Draft                       | <a href="#">DFT0006428</a> |                     |                 | 03/31/2026             |                       | 965.62                |
| <b>Payable Number</b>            | <b>Description</b>         | <b>Payable Date</b> | <b>Due Date</b> | <b>Discount Amount</b> | <b>Payable Amount</b> |                       |
| <a href="#">Mar 2026 Draft</a>   | Draft Court Collections    | 03/31/2026          | 04/30/2026      | 0.00                   | 965.62                |                       |
| Bank Draft                       | <a href="#">DFT0006429</a> |                     |                 | 03/31/2026             |                       | 569,075.82            |
| <b>Payable Number</b>            | <b>Description</b>         | <b>Payable Date</b> | <b>Due Date</b> | <b>Discount Amount</b> | <b>Payable Amount</b> |                       |
| <a href="#">March 2026 Draft</a> | Bond & Interest Payments   | 03/31/2026          | 04/30/2026      | 0.00                   | 569,075.82            |                       |

**Payment Register**

**APPKT01940 - March 2026 Draft**

|   |   |                                   |                               |                                   |  |  |
|---|---|-----------------------------------|-------------------------------|-----------------------------------|--|--|
| <b>Vendor Number</b><br><a href="#">032321</a>            | <b>Vendor Name</b><br>Pitney Bowes                  |                                   |                               |                                   |  | <b>Total Vendor Amount</b><br>4,064.99 |
| <b>Payment Type</b><br>Bank Draft                         | <b>Payment Number</b><br><a href="#">DFT0006427</a> |                                   |                               | <b>Payment Date</b><br>03/31/2026 |  | <b>Payment Amount</b><br>4,064.99      |
| <b>Payable Number</b><br><a href="#">March 2026 Draft</a> | <b>Description</b><br>Pitney Bowes Monthly Postage  | <b>Payable Date</b><br>03/31/2026 | <b>Due Date</b><br>04/30/2026 | <b>Discount Amount</b><br>0.00    |  | <b>Payable Amount</b><br>4,064.99      |
|   |   |                                   |                               |                                   |  |  |
| <b>Vendor Number</b><br><a href="#">037182</a>            | <b>Vendor Name</b><br>Sparklight Business           |                                   |                               |                                   |  | <b>Total Vendor Amount</b><br>1,113.48 |
| <b>Payment Type</b><br>Bank Draft                         | <b>Payment Number</b><br><a href="#">DFT0006421</a> |                                   |                               | <b>Payment Date</b><br>03/31/2026 |  | <b>Payment Amount</b><br>1,113.48      |
| <b>Payable Number</b><br><a href="#">March 2026 Draft</a> | <b>Description</b><br>Monthly Sparklight Draft      | <b>Payable Date</b><br>03/31/2026 | <b>Due Date</b><br>04/30/2026 | <b>Discount Amount</b><br>0.00    |  | <b>Payable Amount</b><br>1,113.48      |
|   |   |                                   |                               |                                   |  |  |
| <b>Vendor Number</b><br><a href="#">035989</a>            | <b>Vendor Name</b><br>Totah Communications, Inc     |                                   |                               |                                   |  | <b>Total Vendor Amount</b><br>56.34    |
| <b>Payment Type</b><br>Bank Draft                         | <b>Payment Number</b><br><a href="#">DFT0006431</a> |                                   |                               | <b>Payment Date</b><br>03/31/2026 |  | <b>Payment Amount</b><br>56.34         |
| <b>Payable Number</b><br><a href="#">March 2026 Draft</a> | <b>Description</b><br>Totah Monthly Draft           | <b>Payable Date</b><br>03/31/2026 | <b>Due Date</b><br>04/30/2026 | <b>Discount Amount</b><br>0.00    |  | <b>Payable Amount</b><br>56.34         |
|   |   |                                   |                               |                                   |  |  |
| <b>Vendor Number</b><br><a href="#">037328</a>            | <b>Vendor Name</b><br>Verizon Gps                   |                                   |                               |                                   |  | <b>Total Vendor Amount</b><br>1,051.22 |
| <b>Payment Type</b><br>Bank Draft                         | <b>Payment Number</b><br><a href="#">DFT0006425</a> |                                   |                               | <b>Payment Date</b><br>03/31/2026 |  | <b>Payment Amount</b><br>1,051.22      |
| <b>Payable Number</b><br><a href="#">March 2026 Draft</a> | <b>Description</b><br>Verizon Monthly Draft         | <b>Payable Date</b><br>03/31/2026 | <b>Due Date</b><br>04/30/2026 | <b>Discount Amount</b><br>0.00    |  | <b>Payable Amount</b><br>1,051.22      |
|   |   |                                   |                               |                                   |  |  |
| <b>Vendor Number</b><br><a href="#">037708</a>            | <b>Vendor Name</b><br>Woodriver Energy LLC          |                                   |                               |                                   |  | <b>Total Vendor Amount</b><br>1,532.88 |
| <b>Payment Type</b><br>Bank Draft                         | <b>Payment Number</b><br><a href="#">DFT0006426</a> |                                   |                               | <b>Payment Date</b><br>03/31/2026 |  | <b>Payment Amount</b><br>1,532.88      |
| <b>Payable Number</b><br><a href="#">March 2026 Draft</a> | <b>Description</b><br>Woodriver Monthly Draft       | <b>Payable Date</b><br>03/31/2026 | <b>Due Date</b><br>04/30/2026 | <b>Discount Amount</b><br>0.00    |  | <b>Payable Amount</b><br>1,532.88      |

### Payment Summary

| Bank Code | Type                  | Payable Count | Payment Count | Discount    | Payment           |
|-----------|-----------------------|---------------|---------------|-------------|-------------------|
| General   | Manual Bank Draft     | 25            | 25            | 0.00        | 847,550.53        |
|           | <b>Packet Totals:</b> | <b>25</b>     | <b>25</b>     | <b>0.00</b> | <b>847,550.53</b> |

### Cash Fund Summary

| Fund                  | Name        | Amount             |
|-----------------------|-------------|--------------------|
| 099                   | Pooled Cash | -847,550.53        |
| <b>Packet Totals:</b> |             | <u>-847,550.53</u> |

**PAY PERIOD 3/13/2026**

**GROSS: \$ 245,663.41**

**PAYROLL DEDUCTIONS**

**FEDERAL & FICA**

**\$ 51,509.54**

|                     |             |
|---------------------|-------------|
| <b>KPERS DRAFTS</b> | <b>OGLI</b> |
|---------------------|-------------|

|                     |            |
|---------------------|------------|
| <b>\$ 53,228.64</b> | <b>\$0</b> |
|---------------------|------------|

**STATE WITHHOLDING**

**\$ 10,898.63**

**PAYROLL EMPLOYEE DEDUCTIONS**

**\$ 21,166.31**



City of Independence

# Payroll Check Register Report Summary

Pay Period: 2/22/2026-3/7/2026

Packet: PYPKT00564 - 3/13/2026 Payroll  
Payroll Set: City of Independence - 01

| Type            | Count      | Amount            |
|-----------------|------------|-------------------|
| Regular Checks  | 1          | 0.00              |
| Manual Checks   | 0          | 0.00              |
| Reversals       | 0          | 0.00              |
| Voided Checks   | 0          | 0.00              |
| Direct Deposits | 146        | 161,892.69        |
| <b>Total</b>    | <b>147</b> | <b>161,892.69</b> |



City of Independence

# Payroll Check Register Report Summary

Pay Period: 2/22/2026-3/7/2026

Packet: PYPKT00567 - 3/13/2026 Payroll  
Payroll Set: City of Independence - 01

| Type            | Count     | Amount          |
|-----------------|-----------|-----------------|
| Regular Checks  | 0         | 0.00            |
| Manual Checks   | 0         | 0.00            |
| Reversals       | 0         | 0.00            |
| Voided Checks   | 0         | 0.00            |
| Direct Deposits | 17        | 1,703.92        |
| <b>Total</b>    | <b>17</b> | <b>1,703.92</b> |



City of Independence

# Payroll Check Register Report Summary

Pay Period: 2/22/2026-3/7/2026

Packet: PYPKT00568 - 3/13/2026-3 Payroll  
Payroll Set: City of Independence - 01

| Type            | Count    | Amount        |
|-----------------|----------|---------------|
| Regular Checks  | 0        | 0.00          |
| Manual Checks   | 0        | 0.00          |
| Reversals       | 0        | 0.00          |
| Voided Checks   | 0        | 0.00          |
| Direct Deposits | 2        | 154.33        |
| <b>Total</b>    | <b>2</b> | <b>154.33</b> |

**PAY PERIOD 3/27/2026**

**GROSS: \$ 251,562.34**

**PAYROLL DEDUCTIONS**

**FEDERAL & FICA**

**\$ 54,038.15**

**KPERS DRAFTS**

**OGLI**

**\$ 56,034.79**

**\$971.43**

**STATE WITHHOLDING**

**\$ 11,193.98**

**PAYROLL EMPLOYEE DEDUCTIONS**

**\$ 21,164.63**



City of Independence

# Payroll Check Register Report Summary

Pay Period: 3/8/2026-3/21/2026

Packet: PYPKT00576 - 3/27/2026 Payroll  
Payroll Set: City of Independence - 01

| Type            | Count      | Amount            |
|-----------------|------------|-------------------|
| Regular Checks  | 0          | 0.00              |
| Manual Checks   | 0          | 0.00              |
| Reversals       | 0          | 0.00              |
| Voided Checks   | 0          | 0.00              |
| Direct Deposits | 149        | 166,943.64        |
| <b>Total</b>    | <b>149</b> | <b>166,943.64</b> |



**REQUEST FOR COMMISSION ACTION  
CITY OF INDEPENDENCE  
April 23, 2026**

**Department Admin**

**Director Approval Kelly Passauer**

**AGENDA ITEM** Consultation with an attorney on matters that would be deemed privileged in an attorney-client relationship.

**SUMMARY RECOMMENDATION**

**BACKGROUND**

**FINANCIAL INFORMATION**

**SUGGESTED MOTION** I move that we recess for an executive session for consultation with an attorney representing the City regarding a legal issue pursuant to the attorney/client privilege exception found at K.S.A. 75-4319(b)(2). The open meeting will resume at \_\_\_\_:\_\_\_\_ p.m. (\_\_ minutes) in the Commission Room of City Hall.

**SUPPORTING DOCUMENTS**